

GIGACER[®]

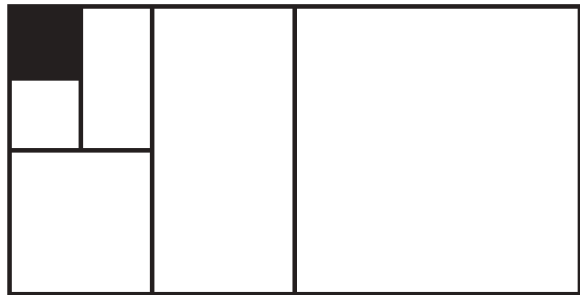

GIGACER[®]

Book 2022

INDEX

/ COLLECTIONS

GIGACER

Argilla	p. 6
Concept 1	p. 14
Concrete	p. 22
Déco	p. 30
Elementa	p. 34
Gatsby	p. 42
Inclusioni Classico	p. 48
Inclusioni Extrafine / Soave	p. 56
Krea	p. 64
Light	p. 72
Made 2.0	p. 80
Quarry	p. 88
Tele	p. 96

Le Colnovi

Béton	p. 104
LCS	p. 108
Tokyo	p. 112
Molitor	p. 116
Pointillé	p. 120

/ SYSTEMS - matching suggestions with our collections

PlayOne & GIGACER MATCHINGS	p. 130
-----------------------------	--------

/ TECHNICAL NOTES

Bordi e top Edges and worktop	p. 156
Lavabi Washbasins	p. 158
Piatti doccia Shower trays	p. 159
Gigacer Service	p. 160
Pezzi speciali Special trims	p. 162
Destinazioni d'uso Intended use classification	p. 164
≠20 mm & ≠24 mm	p. 166
Posa e colla Installation and adhesives	p. 170
Pulizia e manutenzione Cleaning and maintenance	p. 172
Indice di stonalizzazione Shade variation index	p. 176
Calibri Calibers	p. 177
Imballi Packaging	p. 178
Caratteristiche tecniche Technical specifications	p. 182
Certificazioni Certifications	p. 184

Gigacer produce ceramica: originali lastre in gres porcellanato tecnico per l'architettura. La ceramica attraversa la nostra storia, racchiudendo in sé dalle tracce più antiche dell'uomo fino alla miglior tecnologia industriale, che permette la produzione di un materiale sostenibile, ecocompatibile, resistentissimo, igienico e allineato alle tendenze del design contemporaneo. La ceramica è costituita da materiali naturali, è assolutamente inodore, non brucia e, in caso di incendio, non rilascia sostanze nocive. Il made in Italy in ceramica è sinonimo di stile e qualità, grazie al know-how sviluppato dalla manifattura, dalla raffinata tradizione artistica e anche grazie alle contaminazioni con gli altri settori dell'industria del design nazionale. Gigacer, nata a Faenza nel 2008, è figlia di questa terra e di queste competenze. Nasce sulla scorta di una tecnologia innovativa per la produzione di grandi lastre ceramiche e garantisce i migliori standard qualitativi del settore grazie alla competenza dei suoi addetti, cresciuti professionalmente dentro la cultura ceramica italiana. Il gres porcellanato Gigacer è batteriostatico, non permette cioè la proliferazione di batteri o virus sulla sua superficie, ed è notoriamente un materiale facilmente igienizzabile, grazie alla sua durezza e compattezza. Il sito produttivo a Faenza è stato costruito rispettando le migliori prassi europee e regionali, utilizzando tecnologie d'avanguardia e facendo del rispetto dell'ambiente un tratto distintivo e imprescindibile dell'intero progetto. Osservando lo spessore delle lastre 12 mm multilayer si può notare che la base, composta di gres porcellanato ottenuto anche con l'aggiunta del riciclo degli sfridi produttivi, viene ricoperta da uno strato di materiale nobile, composto da gres porcellanato colorato in massa, argille, grani, che vengono depositati sulla superficie prima della pressatura. Questo metodo di lavorazione, oltre a regalare al prodotto un aspetto visibilmente e concretamente materico, ottimizza l'uso dei materiali. Elemento cardine dello sviluppo dell'azienda, come vedrete sfogliando le pagine successive, è lo stile originale: contemporaneo, minimalista, raffinato. Gigacer mantiene fin dall'inizio uno stile univoco: la matericità delle superfici e i loro colori naturalmente eleganti vengono studiati per essere uno sfondo neutro, curato e sofisticato per l'abitare.

Gigacer produces ceramic: innovative technical porcelain stoneware slabs for architecture. Ceramic runs through our history, encompassing from the most ancient traces of mankind to the best industrial technology, which allows the production of a sustainable, environmentally friendly, highly resistant, hygienic material and aligned material with contemporary design trends. The ceramic is made with the use natural elements, it is absolutely odorless, it does not burn and, in the event of a fire, it does not release harmful substances. Made in Italy in ceramics is synonymous with style and quality, thanks to the know-how developed by manufacturing, the refined artistic tradition and also thanks to the contamination with other sectors of the national design industry. Gigacer, born in Faenza in 2008, is the daughter of this land and these skills. It was born on the basis of an innovative technology for the production of large ceramic slabs and guarantees the best quality standards in the sector thanks to the expertise of its employees, who have grown professionally within the Italian ceramic culture. Gigacer porcelain stoneware is bacteriostatic, which means that it does not allow the proliferation of bacteria or viruses on its surface, and is notoriously an easily sanitized material, thanks to its hardness and compactness.

The production site in Faenza was built respecting the best European and Regional practices, using cutting-edge technologies and making respect for the environment a distinctive and essential feature of the entire project. Close observation of the slabs 12 mm multilayer shows that the base - made up of porcelain stoneware obtained partially by the addition of recycled offcuts of the same material - is coated with a layer of noble material made up of porcelain stoneware coloured en masse and clays and grains which are deposited onto the surface prior to pressing. In addition to producing a visibly and concretely material product, this working method optimises material use. The cornerstone of the company's development, as you can see by browsing the following pages, is the original style: contemporary, minimalist and refined. Gigacer maintains a unique style right from the start: the materiality of the surfaces and their naturally elegant colors are designed to be a neutral, refined and sophisticated background for living.

/ GIGACER COLLECTIONS

Argilla

Concept 1

Concrete

Déco

Elementa

Gatsby

Inclusioni

Krea

Light

Made 2.0

Quarry

Tele

Argilla

Argilla riscopre le espressioni più naturali delle terre faentine, le argille, creando una gamma cromatica dalla tonalità pastello, in cui la materia diventa protagonista. Le due superfici della collezione, che interpretano il medesimo colore, sottolineano la plasticità della nostra materia prima: quasi cerosa e morbidissima la superficie Quartz, materica e pastosa Material.

Argilla rediscovers the most natural expressions of the Faentinian lands, the clays, creating a chromatic range with a pastel shade, where the material becomes the main subject. The two surfaces of the collection, which interpret the same color, underline the plasticity of our raw material: the Quartz surface, material and pasty Material, is almost waxy and very soft.



Biacca

Dry

Vetiver

Marine

Fog

Dark

Argilla



Le 6 tonalità di colore sono fra loro affini, interpretate da due diverse superfici:
Quartz e Material ideali per pavimenti e rivestimenti.
 These 6 colours shades are available on two different surfaces:
 Quartz and Material for both floor and wall applications.

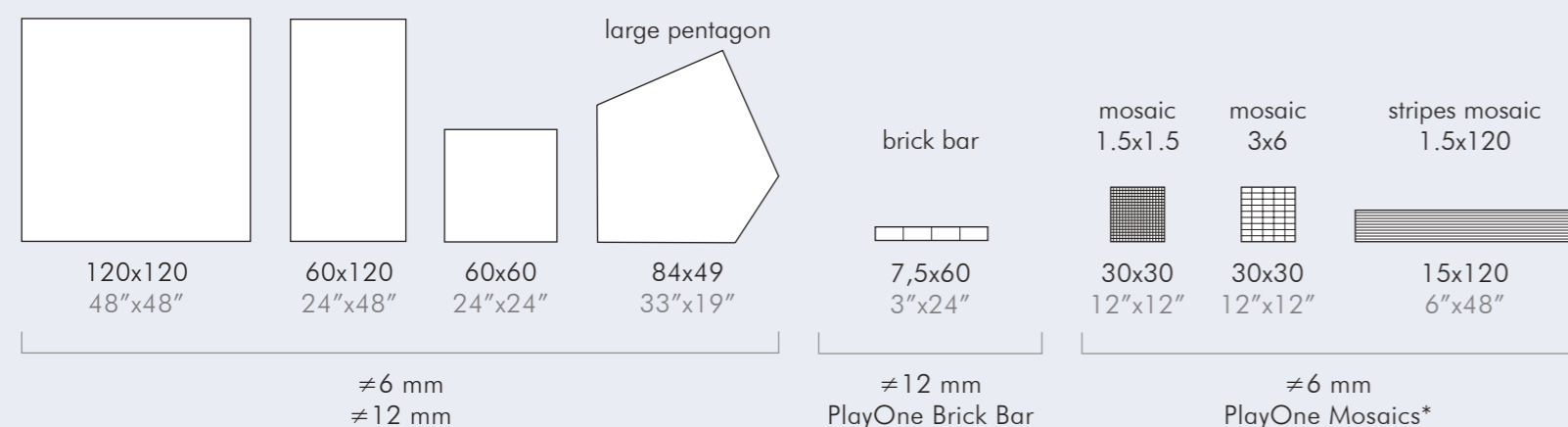
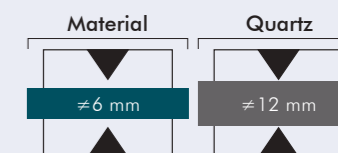

*Mosaici forniti su rete
 Mosaics are mesh-mounted

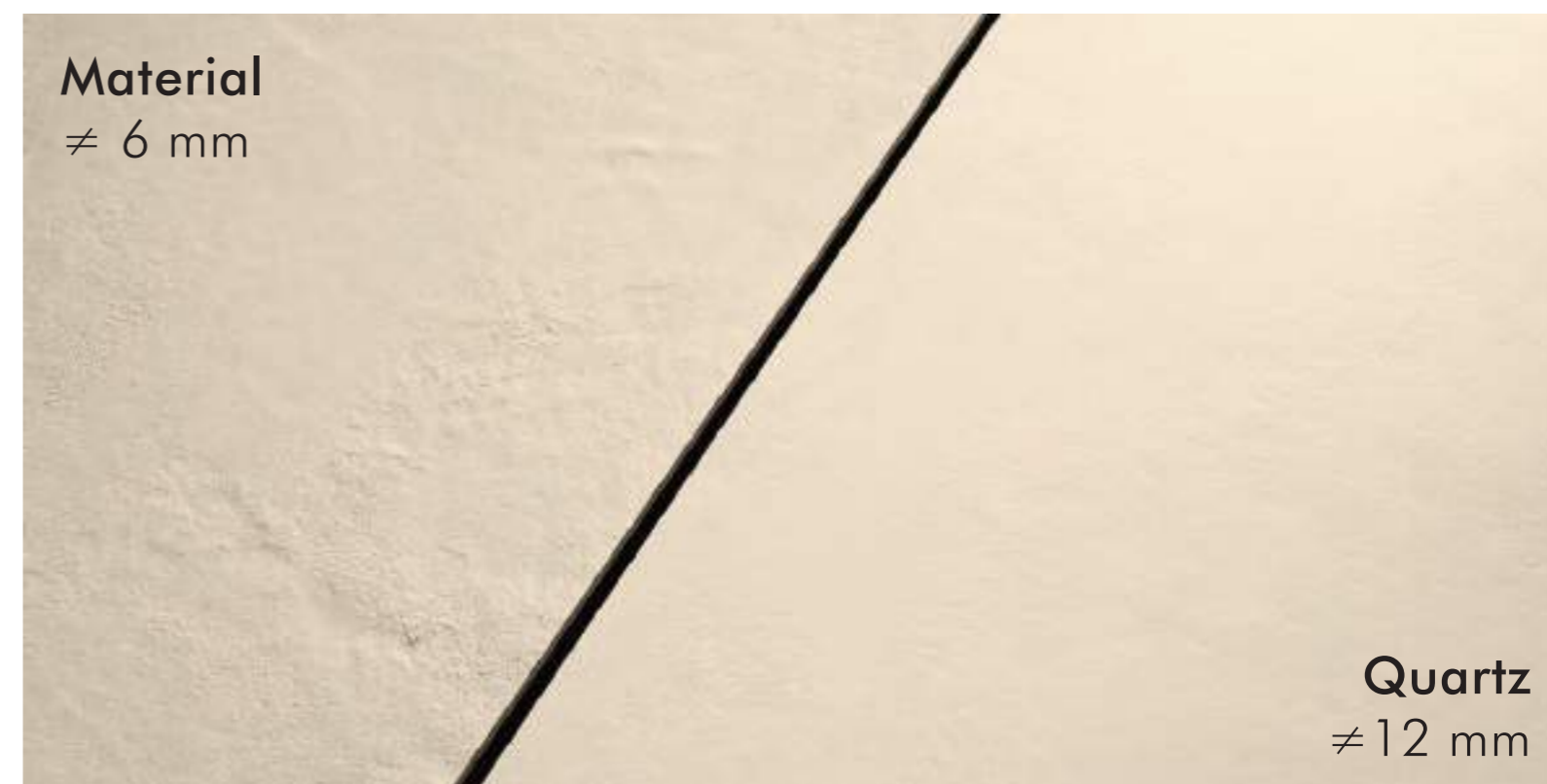



Parete | Wall
Marine Material Argilla
120x120 cm · 48"x48" ≈6 mm

Pavimento | Floor
Marine Quartz Argilla
120x120 cm · 48"x48" ≈12 mm



Parete | Wall
Vetiver Material Argilla
Mosaic 1.5x1.5 - 30x30 cm · 12"x12" ≈6 mm

Lavabo | Washbasin Middle
Vetiver Material Argilla
50x120 cm · 19 1/2"x48"
Gigacer Service ≈6 mm

Pavimento | Floor
Vetiver Material Argilla
120x120 cm · 48"x48" ≈6 mm

Vetiver Material Argilla
Stripes Mosaic 1.5x120 - 15x120 cm · 6"x48" ≈6 mm



Piano dei tavolini | Counter top coffee
All colours Material Argilla
Gigacer Service $\neq 6$ mm

Pavimento | Floor
Fog Material Argilla
120x120 cm · 48"x48" $\neq 6$ mm



Parete | Wall
Dark Material Argilla
Mosaic 3x6 30x30 cm · 12"x12" $\neq 6$ mm

Pavimento | Floor
Fog Material Argilla
120x120 cm · 48"x48" $\neq 6$ mm

Bancone | Counter
Graphite Concrete
Gigacer Service $\neq 12$ mm

Concept 1

Concept 1 è concepire lo spazio con unità di forma e stile, con soluzioni tecniche che conservano continuità estetica attraverso gli ambienti e la loro molteplicità di utilizzi, in interno, in esterno, a parete e nell'arredo, in breve: tutto in uno.

Un'unica gamma in ceramica pensata per ogni tipo di applicazione, con una varietà di colori e superfici combinabili sempre in modo esclusivo e personale. Un gres porcellanato resistente, eclettico, dai toni naturali ed omogenei, con 5 colori di fondo, 5 diverse superfici e 3 spessori.

Concept 1 is to conceive space with unity of form and style, using technical solutions that maintain aesthetic continuity through the environments and their multiplicity of uses, indoors, outdoors, on walls and furniture, in short: all in one.

A unique ceramic range designed for every type of application, with a variety of colours and surfaces that can always be combined in an exclusive and personal way.

A resistant, eclectic porcelain stoneware in natural and homogeneous shades, with 5 colours, 5 different surfaces and 3 thicknesses.

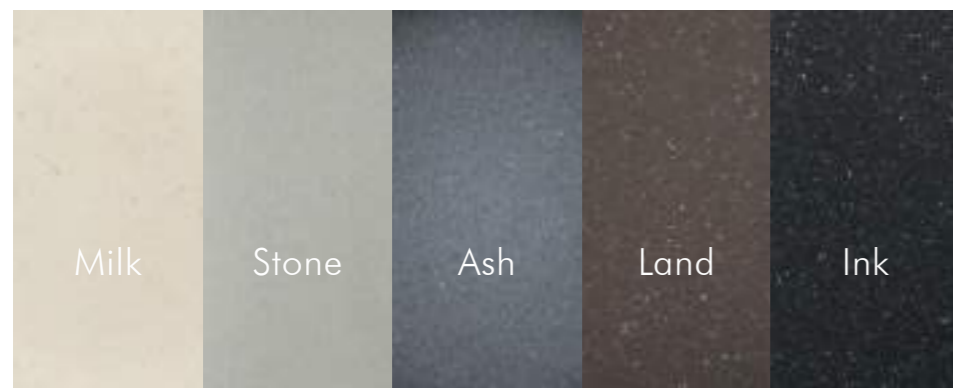

Concept 1



* Disponibile solo nella superficie Bocciardato R10 e R11 multilayer, specificare nell'ordine.
Available only in multilayer Bocciardato R10 and R11 surface, to be specified in the order.

** Disponibile tutta massa non rettificato mat / levigato. Available full body not rectified mat / levigato.

◆ Gli articoli con il marchio Gigacer Service saranno prodotti solo su specifica richiesta e quotati ove necessario (pag. 160).
The products with the Gigacer Service label will be manufactured only upon specific request and they will be quoted where necessary (page 160).

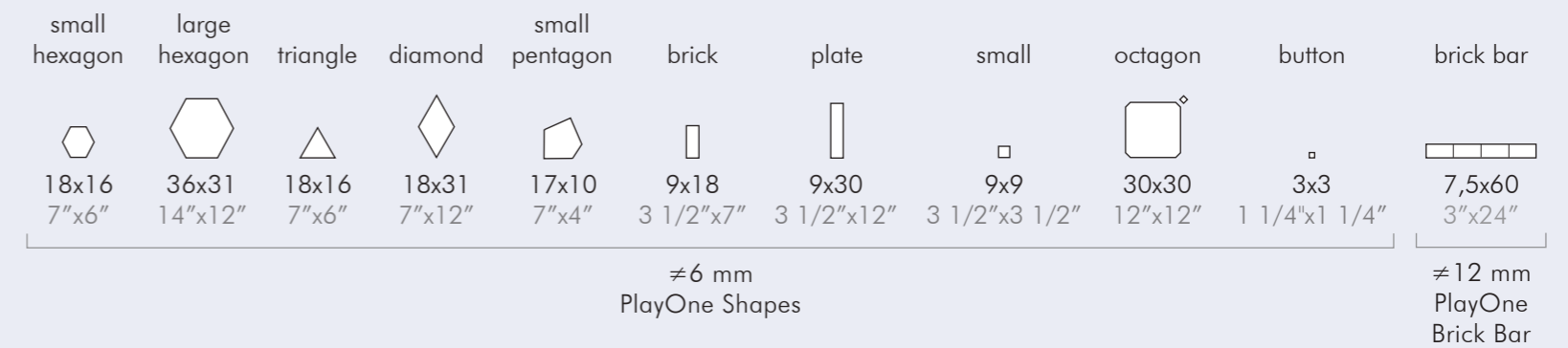
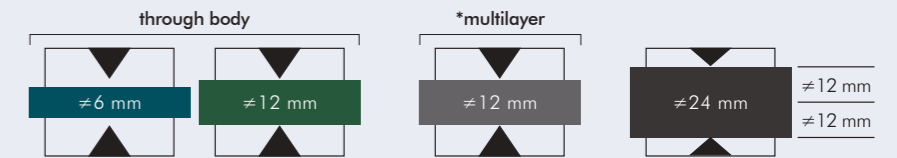

Superfici Surfaces



Colori Colours

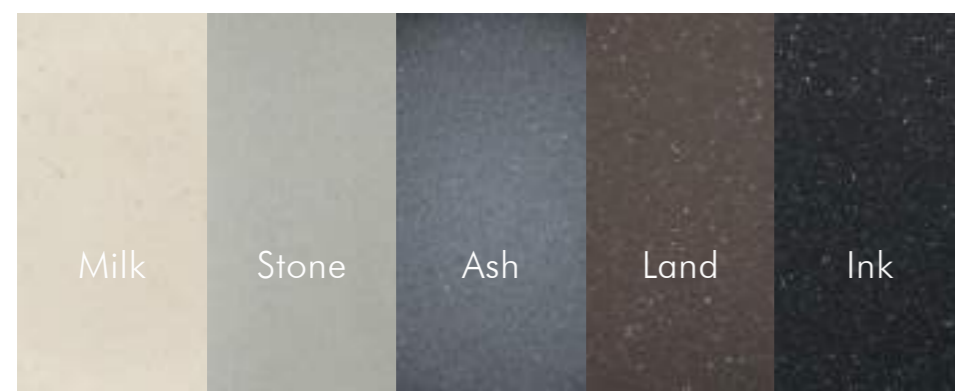

Platinum, Red, Turquoise e Flame Texture Mat sono disponibili solo su base colore Ink.
Platinum, Red, Turquoise and Flame Texture Mat are available on Ink colour basis only.

Mosaici forniti su rete
Mosaics are mesh-mounted

COLORE COLOUR	SUPERFICIE SURFACE	SPESSORE THICKNESS	120x250 48"x100" unrect.	120x250 48"x100"	60x250 24"x100"	120x120 48"x48"	60x120 24"x48"	60x60 24"x24"	30x60 12"x24"	PLAYONE SHAPES	PLAYONE MOSAICS	PLAYONE BRICK BAR
Milk Stone Ash Land Ink	Mat Levigato	# 6	-	•	◆	•	•	•	•	•	•	-
	Texture Mat Texture Levigato	# 6	-	•	◆	•	•	•	•	•	-	-
Milk Ash Land Ink	Mat Levigato	# 12	•	-	-	-	-	-	-	-	-	•
Milk Stone Ash Land Ink	Bocciardato R10 (Also in Bocciardato R11 anti-slip. Specify in the order).	# 12	-	-	-	•	•	•	•	-	-	•
Ink Platinum Ink Red Ink Turquoise Ink Flame	Texture Mat	# 6	-	•	◆	•	•	•	•	◆	◆	-
Milk Stone Ash Land Ink	Mat Bocciardato R10 (Also in Bocciardato R11 anti-slip. Specify in the order).	# 24	-	-	-	◆	◆	◆	-	-	-	-

- Disponibile Available
- Non disponibile Not available



Rivestimento | Wall / Pavimento | Floor

Milk Texture Levigato Concept 1

120x250 cm · 48"x100" ≠6 mm / 20x250 cm · 8"x100" ≠6 mm

Milk Mat Concept 1

60x250 cm · 24"x100" ≠6 mm / 20x250 cm · 8"x100" ≠6 mm

Milk Levigato Concept 1

60x250 cm · 24"x100" ≠6 mm / 40x250 cm · 16"x100" ≠6 mm

Lavabo | Wash basin "Middle"

Milk Mat Concept 1 Mat

50x119 cm · 19 1/2"x48" ≠6 mm



Parete | Wall

(Indoor) Stone Texture Levigato Concept 1

120x250 cm · 48"x100" ≠6 mm

Pavimento | Floor

Stone Bocciardato R11 Concept 1

120x120 cm · 48"x48" ≠12 mm



Parete | Wall

Ink Texture Levigato Concept 1
120x250 cm · 48"x100" ≠6 mm

Ink Mat Concept 1
60x250 cm · 24"x100" ≠6 mm

Ink Turquoise Texture Mat Concept 1
60x250 cm · 24"x100" ≠6 mm

Pavimento | Floor

Ink Bocciardato R11 Concept 1
120x120 cm · 48"x48" ≠12 mm



Ante cucina | Kitchen cabinets / Piano cucina | Kitchen worktop
Land Mat Concept 1
≠6 mm

Tavolo | Table
Land Texture Levigato Concept 1
≠6 mm

Pavimento | Floor
Milk Texture Mat Concept 1
120x120 cm · 48"x48" ≠6 mm

Concrete

Concrete, in sinergia con Made 2.0 (pag. 80), è un flessibile sistema ceramico al servizio degli spazi abitativi. È la paletta di combinazione colori/superfici più completa nelle tinte neutre e naturali: tredici colori e quattro diverse superfici che si adattano alle diverse esigenze dell'abitare. Lo stesso colore può essere utilizzato dall'interno all'esterno, nei pavimenti e nei rivestimenti e per la realizzazione di piani cucina e mobili da bagno mantenendo una forte coerenza cromatica. Tutta la paletta colori Concrete corrisponde ai colori Made 2.0; il colore White equivale al Made 2.0 White Sand.

Concrete, in synergy with Made 2.0 (page 80), is a flexible ceramic system at the service of living spaces. It is the most complete color / surface combination palette in neutral and natural shades: thirteen colors and four different surfaces that adapt to the different needs of living. The same color can be used from inside to outside, in floors and walls and for the creation of kitchen tops and bathroom furniture while maintaining a strong color consistency. The whole Concrete color palette corresponds to the colors Made 2.0; the White color matches the Made 2.0 White Sand.

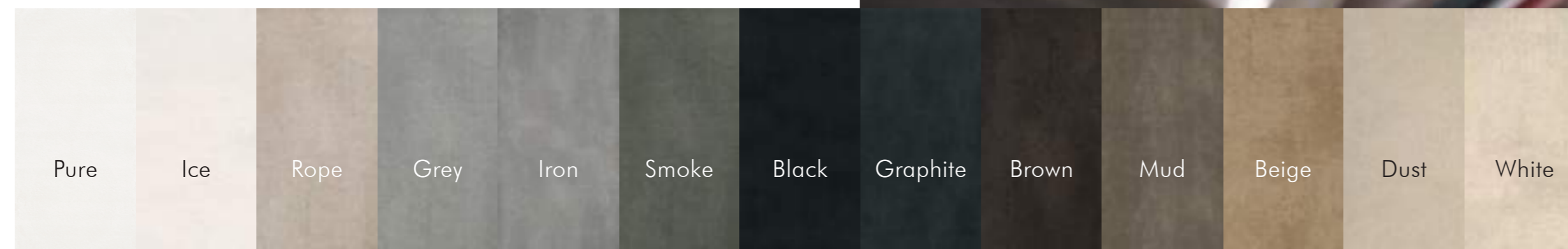

Concrete



***I colori PURE e BLACK sono disponibili solo tutta massa ≠6mm nei formati:**
 The colours PURE and BLACK are available in through body ≠6mm, only in the following sizes:
 120x250, 60x250, 120x120, 60x120, 60x60, 30x60, Mosaic 30x30, Action Mosaic, Stripes Mosaic, Wall Mosaic.

****Disponibile il formato 120x250 rett./non rett. tutta massa nei colori:** Available size 120x250 rect/unrect through body in colours:
 Rope / Grey / Graphite / Mud / White

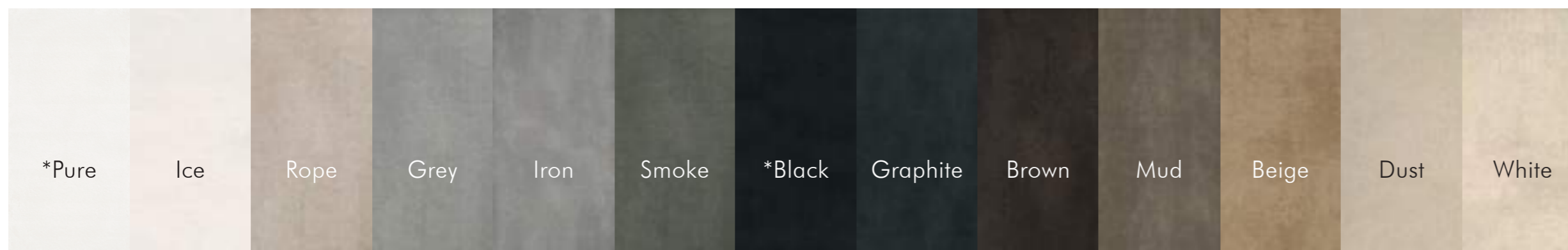
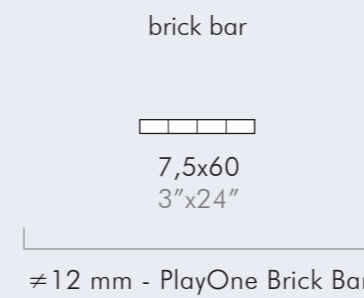
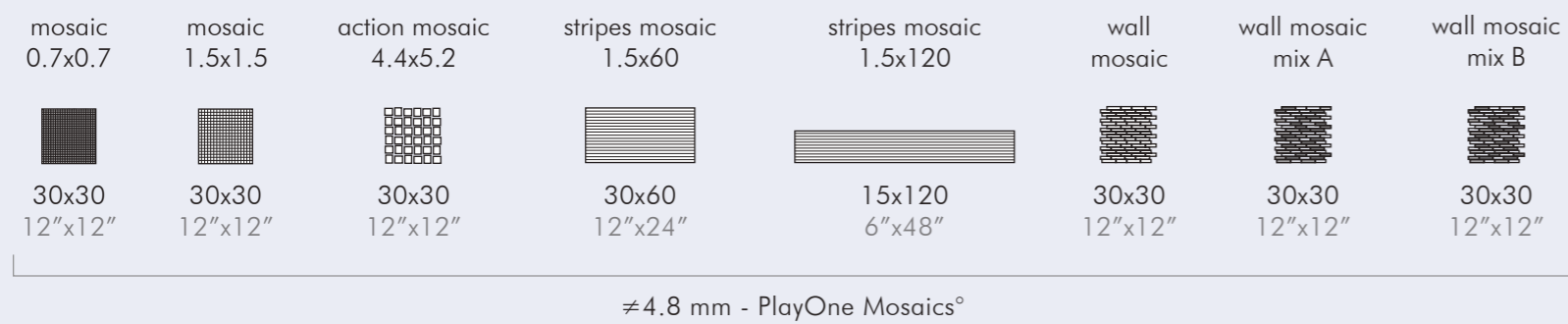
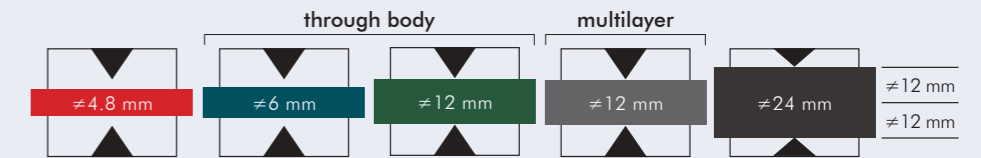
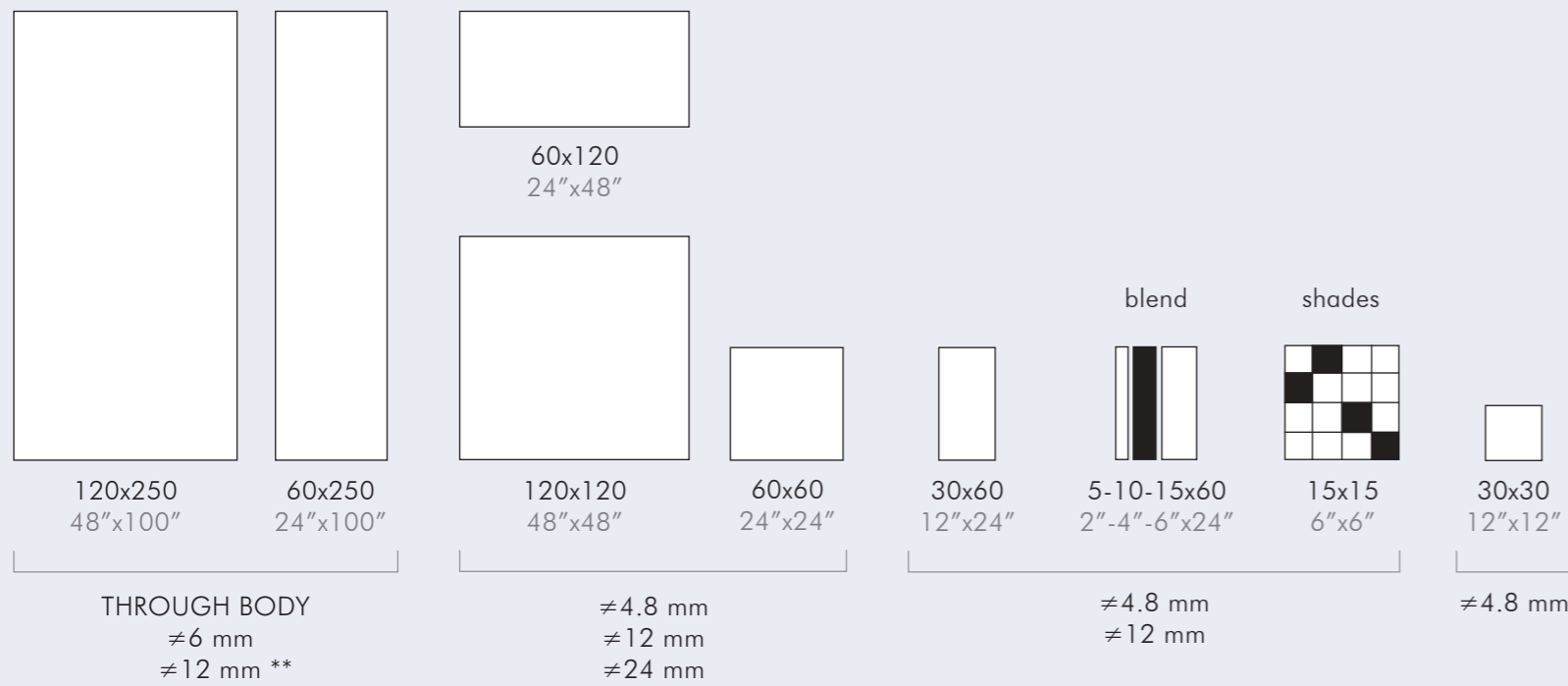

°Mosaici forniti su rete
 Mosaics are mesh-mounted

WALL MOSAIC MIX A
 Solo nei colori: only in the colours: **Brown / Beige / White**

WALL MOSAIC MIX B
 Solo nei colori: only in the colours: **Grey / Smoke / Graphite / White**



Pavimento | Floor
Ice Concrete
120x120 cm · 48"x48" ±12 mm

Gradino costa retta | Costa retta step tread
Ice Concrete
120x33x4 cm · 48"x13"x1 1/2" ±12 mm



Parete | Wall
Ice / White / Rope Concrete
Diamond 18x31 cm · 7"x12" ±4.8 mm

Ice Concrete
15x60 cm · 6"x24" / 10x60 cm · 4"x24" GIGACER Stone Ice ±4.8 mm

Pavimento | Floor
Rope Concrete
60x120 cm · 24"x48" ±4.8 mm

White Concrete
Stripe Mosaic 1.5x120 - 15x120 cm · 48"x6" ±4.8 mm



Pavimento | Floor
Beige Concrete
120x120 cm · 48"x48" ±12 mm

Top cucina | Kitchen worktop
Beige Concrete
Gigacer Service ±12 mm

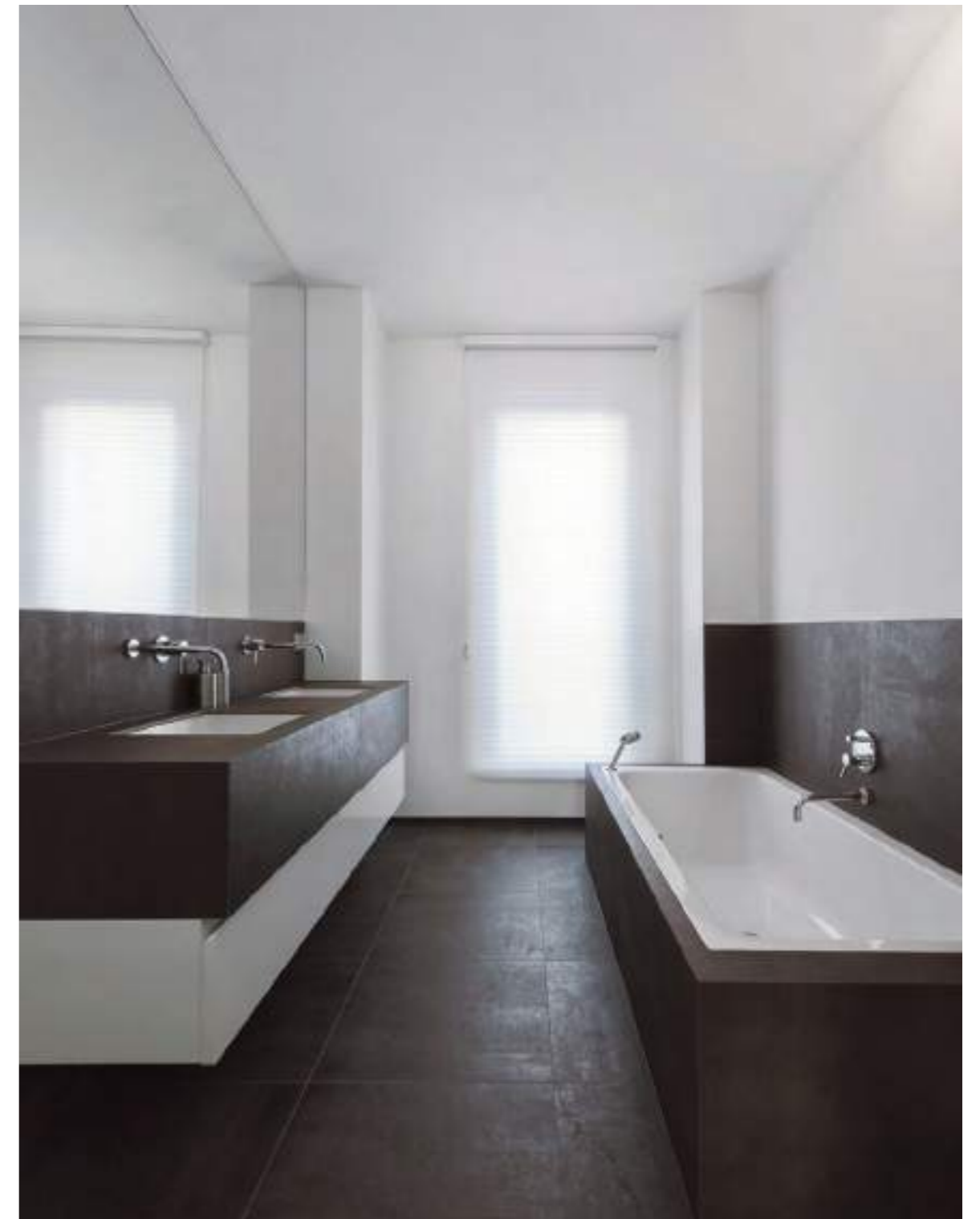

Parete | Wall
Brown Concrete
60x120 cm · 24"x48" ±4.8 mm

Pavimento | Floor
Brown Concrete
60x60 cm · 24"x24" ±12 mm

Lavabo | Washbasin / Vasca | Bathtub
Brown Concrete
Gigacer Service ±6 mm

Déco

Déco si affida alle linee curve e ai dettagli floreali di un paesaggio immaginario, lasciando prevalere l'aspetto vetroso e traslucido ad effetto "ceramico". Si articola in tre gruppi cromatici, definiti in base a tre paesaggi, ognuno ispirato ai toni che lo connotano: Arctic, Mountain e Tropic. Viene presentata inoltre una lastra monocromatica dal fondo bianco neutro, tonalità inclusa in tutte le tre lastre colorate, che può essere utilizzata in abbinamento a tutta la collezione.

Déco relies on the curved lines and floral details of an imaginary landscape, allowing the glass-like and translucent "ceramic" effect prevail. Déco is divided into three colour groups, defined according to three landscapes, each inspired by the tones that characterize it: Arctic, Mountain and Tropic. A monochromatic slab with a neutral white background is presented too, a shade included in all three coloured options, which can be used in combination with the entire collection.



Déco

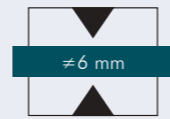

Si consiglia di tagliare questa collezione a disco.
We recommend to cut this collection using the wet saw.



A

B



Basic White

Arctic

Mountain

Tropic

Grafiche continue Continuous graphics

Le lastre 120x250 cm vengono prodotte in due soggetti per ogni colore e per poter creare una posa continua (alternando i soggetti A/B/A/B...).

The 120x250 slabs are manufactured in 2 subjects for each colour to create a continuous scheme (alternation A/B/A/B ...).



Basic White

Arctic

Mountain

Tropic

❖ Gli articoli con il marchio Gigacer Service saranno prodotti solo su specifica richiesta e quotati ove necessario (pag. 160).

The products with the Gigacer Service label will be manufactured only upon specific request and they will be quoted where necessary (page 160).



Parete | Wall
Mountain Déco
❖ Gigacer Service ≠6 mm

Black / Pure Concrete
120x250 cm · 48" x 100" ≠6 mm

Pavimento | Floor
Black / Pure Concrete
120x120 cm · 48" x 48" ≠6 mm

Elementa

L'evoluzione della pietra, tra passato, presente e futuro. L'estetica della nuova linea ELEMENTA celebra la bellezza imprevedibile della natura, reinventando i segni del passato grazie alla tecnologia. Materia che evolve e si trasforma, sempre unica e irripetibile, ELEMENTA è la perfetta fusione tra la tecnicità e le performance del gres porcellanato tipico di Gigacer e la precisione di uno studiato e attento disegno digitale che perfeziona e arricchisce il prodotto.

Una linea dal carattere forte e deciso, in cui l'intensità dell'elemento naturale, rafforzata dalla solidità e resistenza del gres, è attenuata e resa più versatile dalla gamma cromatica composta da tre tonalità neutre, facilmente abbinabili per soddisfare qualsiasi esigenza progettuale. "ivory", la nuance più delicata e leggera, "cool", il colore che esprime l'essenza più fredda e rocciosa e "warm", la gradazione più calda.

The evolution of stone through past, present and future. The aesthetic of the new ELEMENTA line celebrates the unpredictable beauty of nature, reinventing the signs of the past with the help of technology. A material that evolves, forever transforming itself into something unique and inimitable, ELEMENTA perfectly fuses the technicity and performance typical of Gigacer porcelain stoneware and the precision of researched and carefully considered digital design that perfects and enriches the product.

A range that features a strong and decisive character, in which the intensity of the natural element, reinforced by the solidness and durability of stoneware, is softened and made more versatile by a color palette consisting of three neutral tones that can be easily paired to satisfy any style requirement: "ivory", the lightest and most delicate nuance; "cool", whose intensity expresses its cold and rocky essence; and "warm", the more earthy shade.

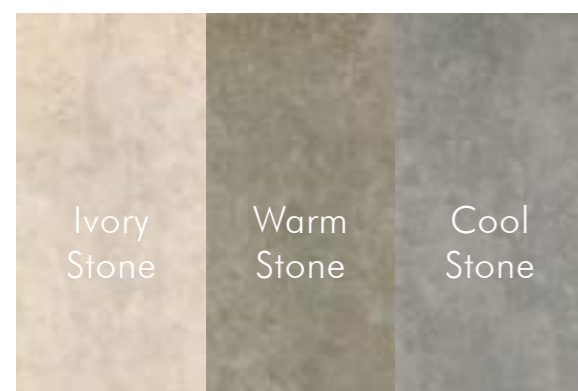

Elementa



❖ Gli articoli con il marchio Gigacer Service saranno prodotti solo su specifica richiesta e quotati ove necessario (pag. 160).
The products with the Gigacer Service label will be manufactured only upon specific request and they will be quoted where necessary (page 160).

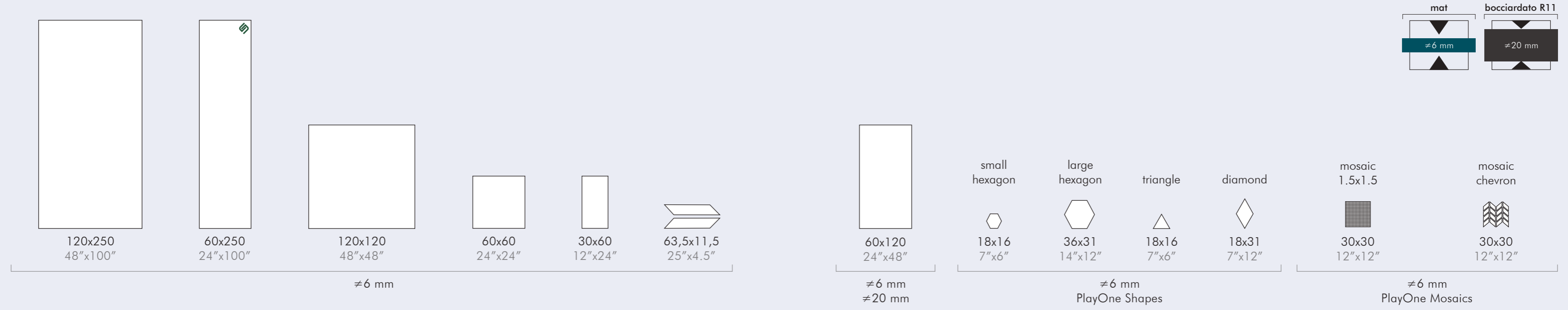

Mosaici forniti su rete
Mosaics are mesh-mounted



Rivestimento | Wall
Ivory Stone Mat Elementa
120x120 cm · 48"x48" ≈6 mm

Pavimento | Floor
Ivory Stone Mat Elementa
120x250 cm · 48"x100" ≈6 mm

Camino | Fireplace
Vulcano Mat Inclusioni Extrafine
Gigacer Service ≈6 mm



Parete | Wall
Cool Stone Mat Elementa
120x250 cm · 48"x100" ≈6 mm

Pavimento | Floor
(Indoor) Cool Stone Mat Elementa
60x120 cm · 24"x48" ≈6 mm

(Outdoor) Cool Stone Bocciardato R11 Elementa
60x120 cm · 24"x48" ≈20 mm



Parete | Wall
Warm Stone Mat Elementa
120x250 cm · 48"x100" ≈6 mm

Pavimento | Floor
Warm Stone Mat Elementa
120x120 cm · 48"x48" ≈6 mm



Parete | Wall
Warm Stone Mat Elementa
120x250 cm · 48"x100" ≈6 mm

Warm Stone Mat Elementa
Mosaic Chevron 30x30 cm · 12"x12" ≈6 mm

Pavimento | Floor
Warm Stone Mat Elementa
Mosaic 1.5x1.5 30x30 cm · 12"x12" ≈6 mm

Gatsby

Stile, raffinatezza e versatilità per la nuova linea "Gatsby". Piccole scintille dall'effetto vibrante e dinamico percorrono elegantemente la superficie dando vita ad un pattern geometrico moderno e raffinato. I segni a rilievo sulla superficie materica creano una trama dalle infinite valenze stilistiche e semantiche, trasformando un prodotto apparentemente semplice in un mix perfetto tra stile decorativo, appeal contemporaneo ed eleganza senza tempo. La gamma cromatica profonda e diversificata genera nuove vibrazioni di forma e colore e diventa un passepartout per creare infinite combinazioni.

Style, refinement and versatility for the new "Gatsby" line. Small sparks with a vibrant and dynamic effect elegantly feature the surface, giving life to a modern and refined geometric pattern. The signs in relief on the material surface create a texture with endless stylistic and semantic values, transforming an apparently simple product into a perfect mix of decorative style, contemporary appeal and timeless elegance. The deep and diversified chromatic range generates new vibrations of shape and colour, becoming a passepartout to create infinite combinations.



Old
Yellow

Long
Island

Green
Light

Jazz

Charleston

Gatsby

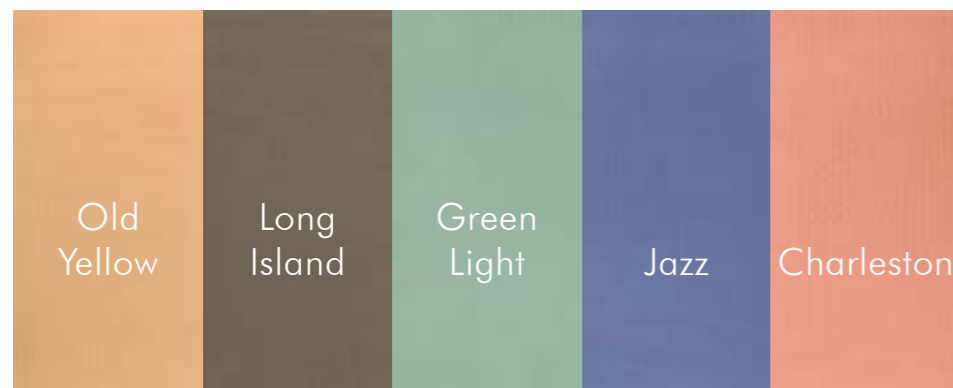
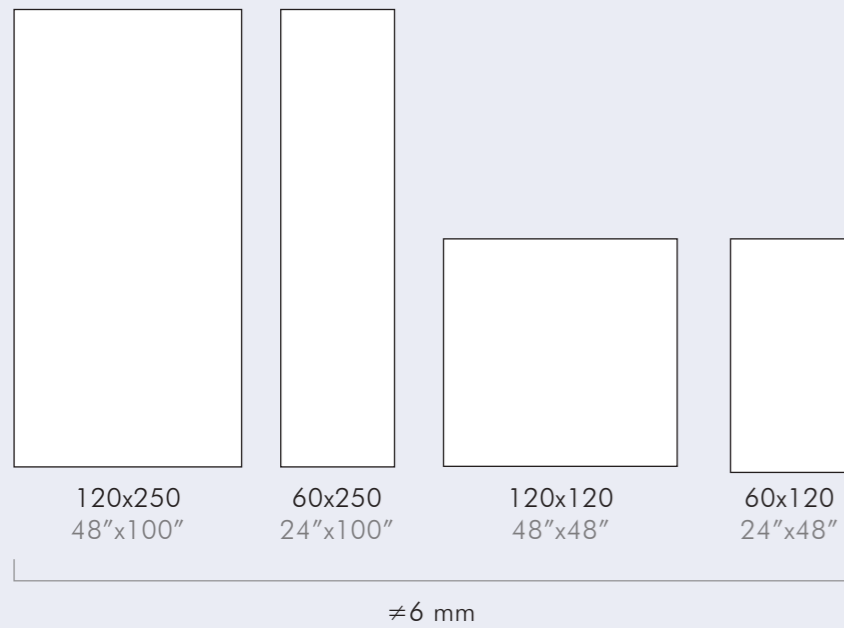



Rivestimento | Wall
Charleston Gatsby
120x250 cm · 48"x100" ±6 mm

Twill Light 250
120x250 cm · 48"x100" ±6 mm

Pavimento | Floor
Vetiver Material Argilla
120x120 cm · 48"x48" ±6 mm



Rivestimento | Wall
Long Island Gatsby
120x250 cm · 48"x100" ±6 mm

Pavimento | Floor
Rope Concrete
120x120 cm · 48"x48" ±6 mm

Inclusioni

Classico

Nella collezione Inclusioni Classico, nuove cromie dal forte impatto visivo configurano le superfici, le modellano e le condizionano. L'espressività senza tempo del colore incontra le potenzialità dello spessore pieno e materico, denso di prospettive e significati: il materiale a tutta massa conferma la sua versatilità, aprendo la strada a molteplici applicazioni. Tra accenti vintage e richiami classicheggianti, il carattere eclettico di Inclusioni Classico si adatta a diversi stili di interior design, inserendosi con eleganza e personalità in contesti moderni e contemporanei, ai quali conferisce un'eleganza intramontabile. L'abbinamento delle diverse varianti di colore e l'accostamento con altri materiali come il metallo, il legno e i tessuti crea accenti particolari ampliando le possibilità creative e dando vita a nuove architetture dal fascino senza tempo.

In the Inclusioni Classico collection, new shades with a strong visual impact model and condition the surfaces. The timeless expressiveness of color meets the potential of the deep and material thickness, overflowing with perspectives and meanings: the full-body ceramic confirms its versatility, paving the way for multiple applications. Between vintage accents and classical references, Inclusioni Classico's eclectic character adapts to different styles of interior design, fitting with elegance and personality into modern and contemporary settings, to whom it lends a timeless and refined elegance. The combination of the different color variations with materials such as metal, wood and fabrics generates special accents, expanding the creative possibilities and giving life to new architectures with timeless charm.



Avorio

Grigio

Terra

Nero

Nero
Giada

Ocra

Ambra

Rosso

Inclusioni

Classico

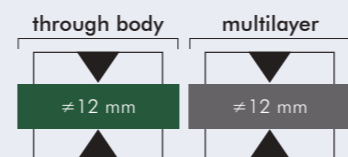
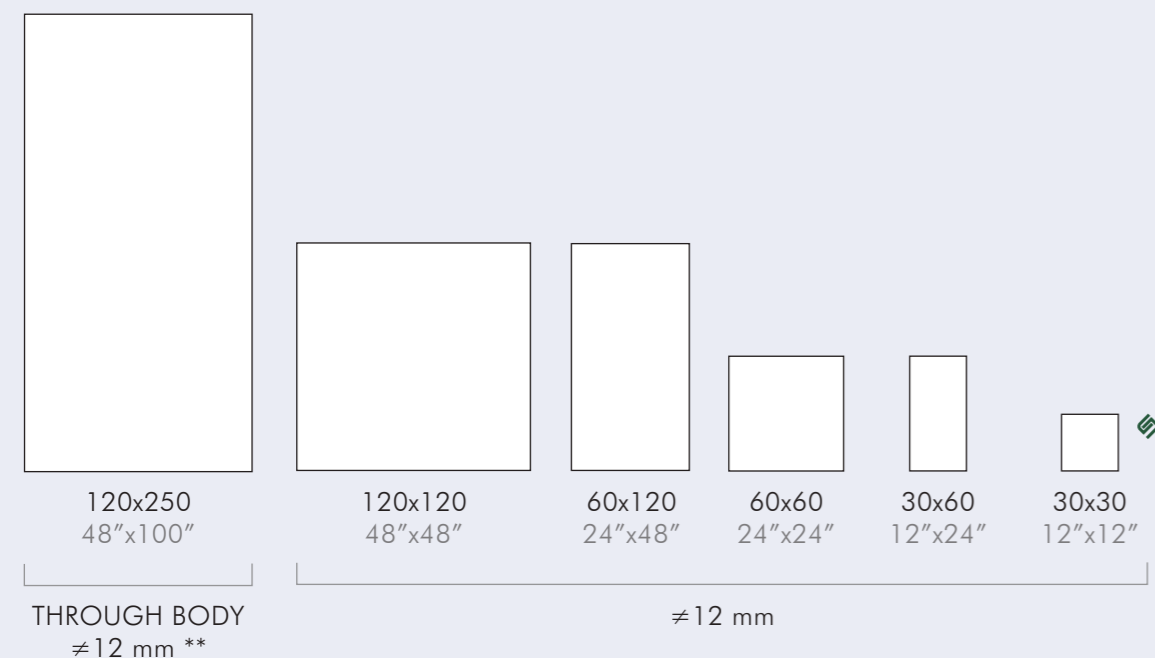

****Disponibile il formato 120x250 rett./non rett.**
Available size 120x250 rect/unrect through body

◆ **Gli articoli con il marchio Gigacer Service saranno prodotti solo su specifica richiesta e quotati ove necessario (pag. 160).**
The products with the Gigacer Service label will be manufactured only upon specific request and they will be quoted where necessary (page 160).



Pavimento | Floor
 Ocra Mat Inclusioni Classico
 60x60 cm · 24"x24" ≈ 12 mm
 Avorio Mat Inclusioni Classico
 30x60 cm · 12"x24" ≈ 12 mm
 ◆ Gigacer Service
 Ambra Mat Inclusioni Classico
 30x30 cm · 12"x12" ≈ 12 mm
 ◆ Gigacer Service



Pavimento | Floor
Avorio - Nero Levigato Inclusioni Classico
120x120 cm · 48"x48" ±12 mm
Avorio - Nero Levigato Inclusioni Classico
30x120 cm · 12"x48" ±12 mm Gigacer Service
Avorio - Nero Levigato Inclusioni Classico
30x30 cm · 12"x12" ±12 mm Gigacer Service



Parete | Wall
Nero - Grigio Mat Inclusioni Classico
Gigacer Service ±12 mm
Pavimento | Floor
Rosso - Ocra - Nero - Grigio Mat Inclusioni Classico
Gigacer Service ±12 mm



Tavolo | Table

Terra Levigato Inclusioni Classico
Gigacer Service Tutta massa / Full body \approx 12 mm

Pavimento | Floor

Ocra Mat Inclusioni Classico
120x120 cm · 48"x48" \approx 12 mm

Terra Mat Inclusioni Classico
120x120 cm · 48"x48" \approx 12 mm

Avorio Mat Inclusioni Classico
60x120 cm · 24"x48" \approx 12 mm



Parete | Wall

Rosso Inclusioni Classico
120x120 cm · 48"x48" \approx 12 mm

White Concrete
120x250 cm · 48"x100" \approx 6 mm

Pavimento | Floor

Rosso Inclusioni Classico
120x120 cm · 48"x48" \approx 12 mm

Lavabo "Double" | Wash basin "Double"

Rosso Inclusioni Classico
50x180 cm · 19 1/2"x71" \approx 12 mm
Gigacer Service Tutta massa / Full body

Inclusioni

Extrafine / Soave

Ispirata dalla forza paziente della natura, Inclusioni unisce la poesia dei colori e l'espressività delle forme aprendo la strada ad infinite possibilità creative. Le sue superfici sono autenticamente materiche e raffinate: scaglie in gres porcellanato prodotte sotto il sapiente controllo dei tecnici del nostro laboratorio vengono deposte sulla superficie e inglobate; il risultato è un effetto tangibile e tridimensionale. Cinque i colori degli ambienti: Bianco Perla, Ecrù, Tabacco, Cenere e Vulcano che spaziano dal bianco al nero passando da una nota riscaldata di lionato. Due le versioni della superficie: Inclusioni Soave mostra l'armonia dei materiali fusi nei toni e nelle forme, Inclusioni Extrafine è l'amalgama finale del complesso cromatico.

Inspired by the force of the nature, Inclusioni blends the intensity of color and the poetry of shape creating endless creative possibilities. Surfaces are authentically material and refined: porcelain stoneware flakes produced under the skilful control of our laboratory technicians are deposited on the surface and incorporated; the result is a tangible and three-dimensional effect. Five colours available: Bianco Perla, Ecrù, Tabacco, Cenere and Vulcano ranging from the white to black passing from a heated note of lionato. There are two versions available of the surface: Inclusioni Soave shows the harmony of the materials fused in tones and shapes, whilst Inclusioni Extrafine is the final amalgam of the chromatic complex.



Inclusioni

Extrafine / Soave

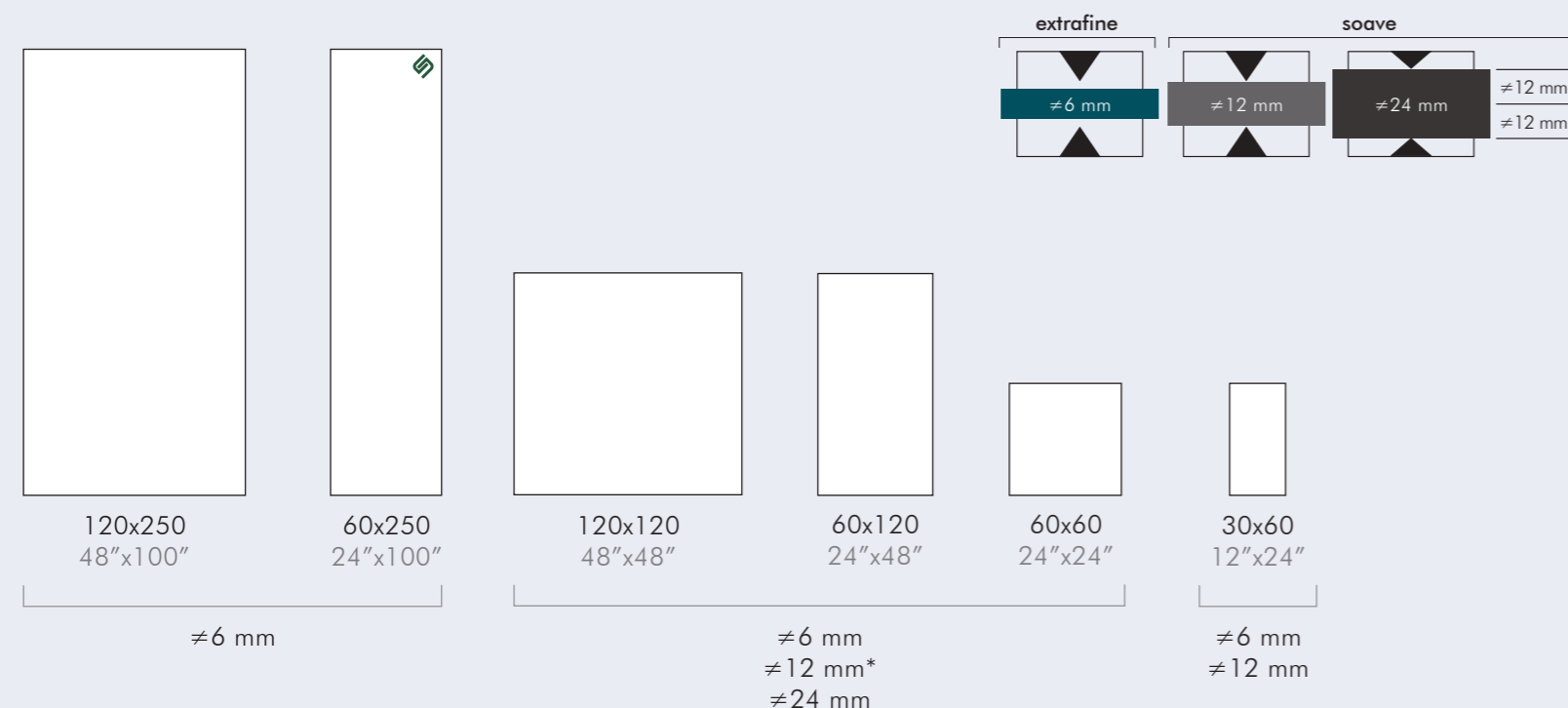

* Disponibile nella superficie Bocciardato R10 e R11, specificare nell'ordine.
Available Bocciardato R10 and R11 surface, specify in the order.

◆ Gli articoli con il marchio Gigacer Service saranno prodotti solo su specifica richiesta e quotati ove necessario (pag. 160).
The products with the Gigacer Service label will be manufactured only upon specific request and they will be quoted where necessary (page 160).



COLORE COLOUR	SUPERFICIE SURFACE	SPESORE THICKNESS	120x250 48"x100"	60x250 24"x100"	120x120 48"x48"	60x120 24"x48"	60x60 24"x24"	30x60 12"x24"
Bianco Perla Ecrù Tabacco Cenere Vulcano	Extrafine Mat Extrafine Levigato	# 6	•	◆	•	•	•	•
Bianco Perla Ecrù Tabacco Cenere Vulcano	Soave Soft Soave Mat	# 12	-	-	•	•	•	•
Bianco Perla Ecrù Tabacco Cenere Vulcano	Soave Bocciardato R10 (Also in Bocciardato R11 anti-slip. Specify in the order).	# 12	-	-	•	•	•	-

- **Disponibile** Available
- **Non disponibile** Not available





Parete | Wall
Ecrù Mat Inclusioni Extrafine
120x250 cm · 48"x100" ≠6 mm

Pavimento | Floor
(Indoor) Ecrù Mat Inclusioni Soave
120x120 cm · 48"x48" ≠12 mm

(Outdoor) Ecrù Bocciardato R11 Inclusioni Soave
120x120 cm · 48"x48" ≠12 mm



Parete | Wall
Vulcano Mat Inclusioni Extrafine
120x250 cm · 48"x100" ≠6 mm

Vasca | Bathtub
Vulcano Mat Inclusioni Extrafine
Gigacer Service ≠6 mm

Pavimento | Floor
Vulcano Mat Inclusioni Extrafine
120x250 cm · 48"x100" ≠6 mm



Pavimento | Floor
Bianco Perla Soft Inclusioni Soave
120x120 cm · 48"x48" ≠12 mm



Pavimento | Floor
Tabacco Mat Inclusioni Soave
120x120 cm · 48"x48" ≠12 mm

Krea

Otto colori che interpretano la materia dei cementi e delle resine colorate in chiave moderna. La serie Krea consente di utilizzare colori vivaci e sfumature decise, oltre che in ambito residenziale, anche nei progetti pubblici, grazie alle elevate caratteristiche tecniche fornite dal gres porcellanato rigorosamente non smaltato. Una soluzione dal carattere deciso, adeguata all'abitare contemporaneo.

Eight colours that interpret cements and coloured resins in a modern way. Krea range allows you to use bright colors and bold shades both in residential and in public projects, thanks to the high technical characteristics provided by the unglazed porcelain stoneware. A solution with a decisive character, suitable for contemporary living.



Ground

Nut

Silver

Snow

Red

Orange

Green

Blue

Krea



La struttura superficiale, sia nello spessore 4,8mm/6mm che nel 12mm, è la stessa di Concrete. È quindi possibile combinare le due serie, entrambe rettificate e monocalibro, in tutti i formati disponibili. The surface texture is the same as in Concrete, both in 4,8mm/6mm and 12mm thickness. It is therefore possible to combine the two ranges, both rectified in the same calibre, in all available formats.

****Disponibile il formato 120x250 e 60x250 nei colori: Available sizes 120x250 and 60x250 in colours: Ground, Nut, Silver, Snow, Orange, Green e Blue.**

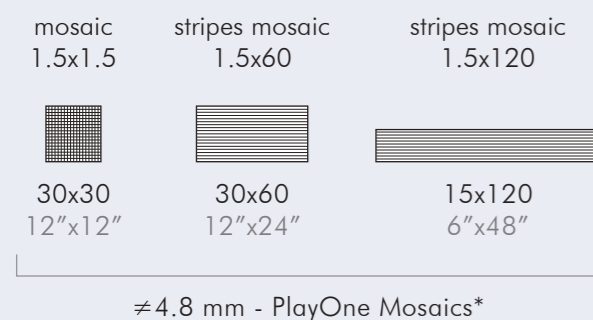
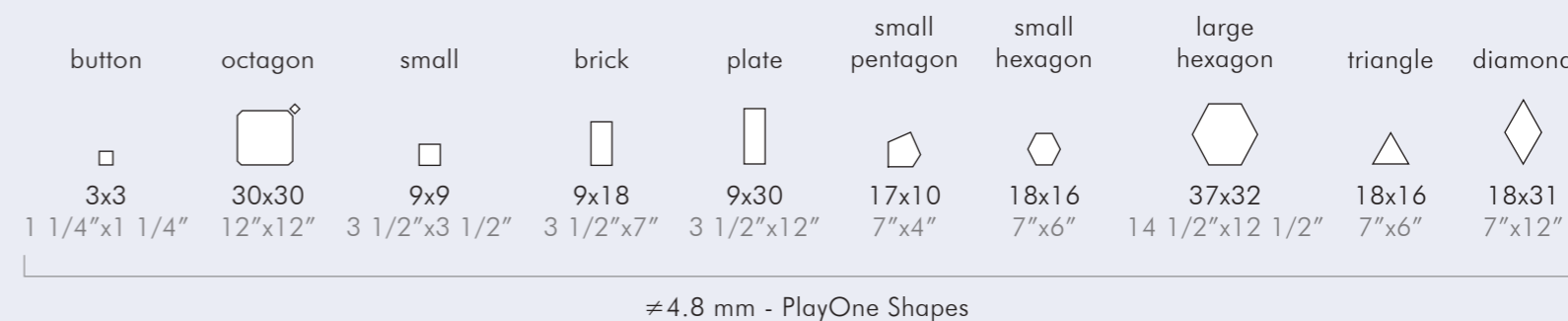
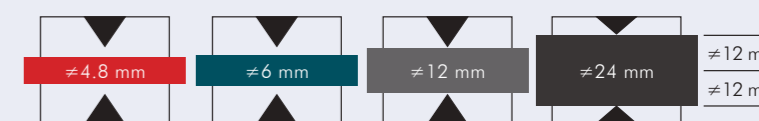
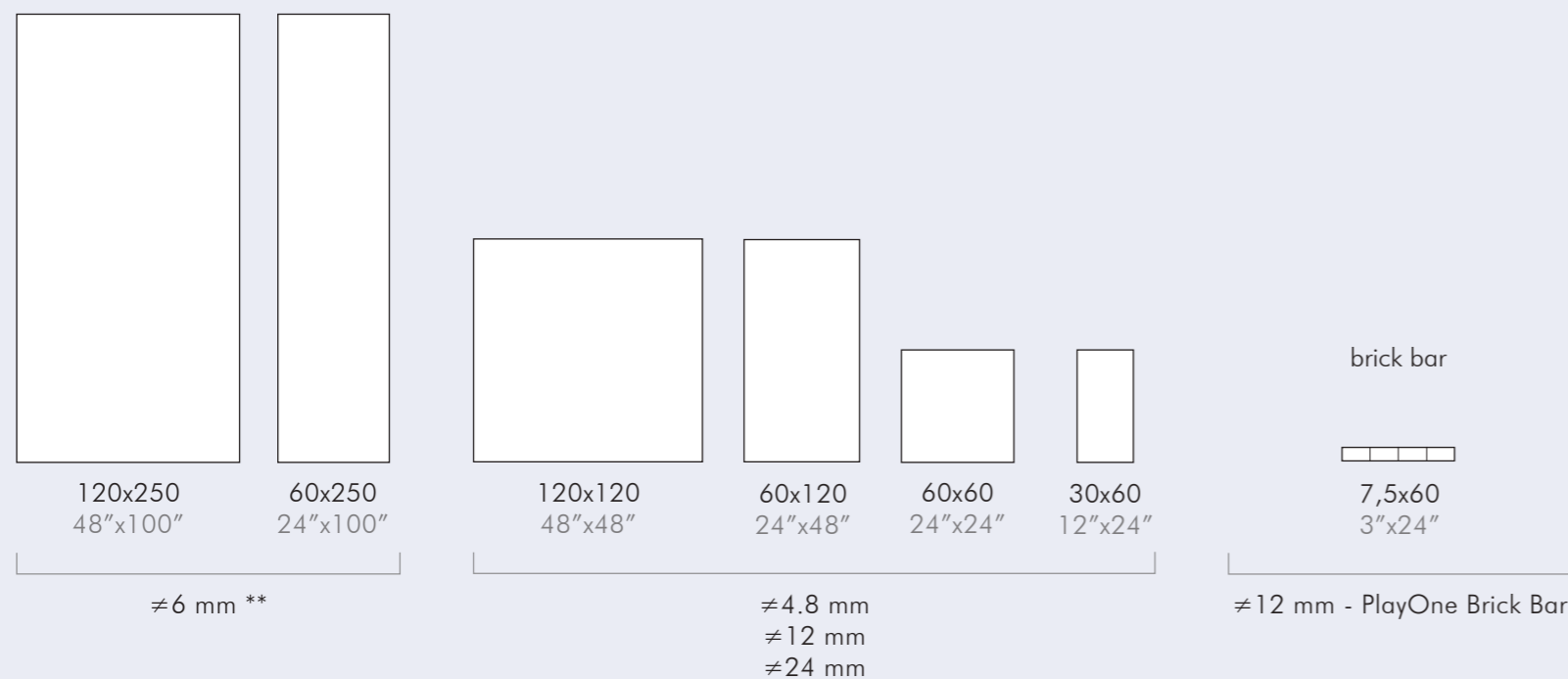

***Mosaici forniti su rete**
Mosaics are mesh-mounted

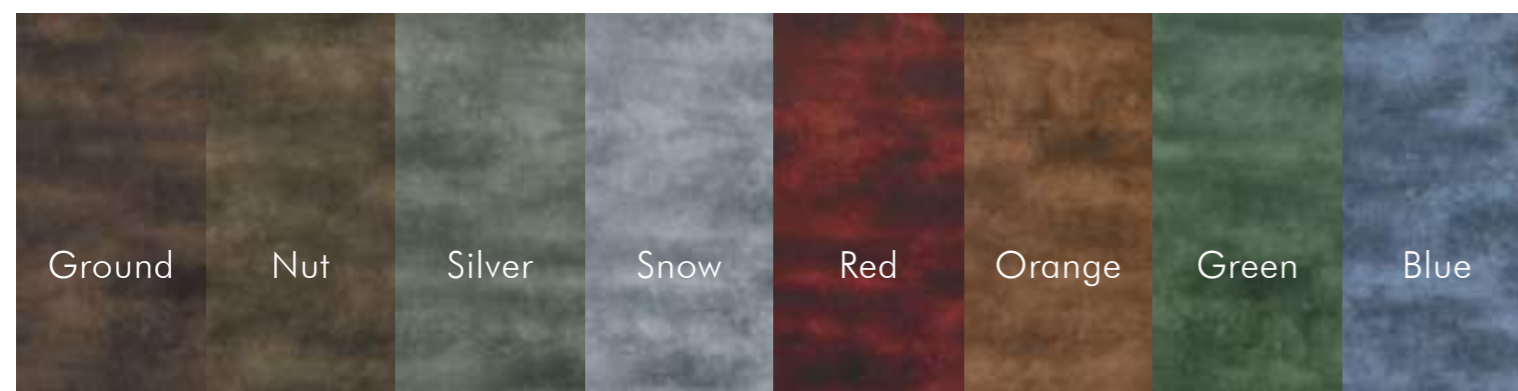



Parete | Wall
 Green / Snow Krea
 Brick Bar 7,5x60 cm · 3"x24" ≠12 mm

Top cucina | Kitchen worktop
 Graphite Concrete
 Gigacer Service

Pavimento | Floor
 Ground Krea
 120x120 cm · 48"x48" ≠12 mm



Pavimento | Floor
 Snow / Green Krea
 30x30 cm · 12"x12" ≠4.8 mm Gigacer Service

Red Krea
 Diamond 18x31 cm · 7"x12" ≠4.8 mm

Silver Krea
 Plate 9x30 cm · 3 1/2"x12" ≠4.8 mm

Silver Krea
 Brick 9x18 cm · 3 1/2"x7" ≠4.8 mm



Parete | Wall
Red / Green / Snow Krea
Small Hexagon
18x16 cm · 7"x6" ≈4.8 mm

Snow / Green Krea
Brick Bar
7,5x60 cm · 3"x24" ≈12 mm

Orange / Ground Krea
Large Hexagon
36x31 cm · 14"x12" ≈4.8 mm

Pavimento | Floor
Ground Krea
120x250 cm · 48"x100" ≈6 mm



Parete | Wall
Orange / Ground Krea
Large Hexagon
36x31 cm · 14"x12" ≈4.8 mm

Pavimento | Floor
Ground Krea
120x120 cm · 48"x48" ≈12 mm

Light

Un innovativo sistema di materiali in gres porcellanato che gioca con la luce e con la materia: LIGHT. È la luce ad evidenziare la struttura materica delle otto superfici, esaltandone la varietà plastica espressiva. Light è anche la materia: leggera, perché questa gamma completamente bianca è formata da uno spessore sottile di pura materia candida.

An innovative system of white porcelain stoneware materials centered on light and on texture: LIGHT. It is light that transforms these eight textural surfaces, enhancing their expressive variety. Light is also the material: light, because this completely white range is composed by a thin thickness of pure white matter.



Light

Le 5 superfici nel formato Blend 20x20/15x60 sono vendute in scatole già miscelate.
The 5 surfaces in Blend 20x20/15x60 size are sold in pre-mixed packages.

Light 250



6 mm / 12 mm solo/only Gesso

120x120 48"x48"	60x120 24"x48"	60x60 24"x24"	30x60 12"x24"	15x60 6"x24"	20x20 8"x8"	brick bar 7,5x60 3"x24"
--------------------	-------------------	------------------	------------------	-----------------	----------------	-------------------------------

6 mm - PlayOne Shapes

button 3x3 1 1/4"x1 1/4"	octagon 30x30 12"x12"	small 9x9 3 1/2"x3 1/2"	brick 9x18 3 1/2"x7"	plate 9x30 3 1/2"x12"	small pentagon 17x10 7"x4"	small hexagon 18x16 7"x6"	large hexagon 37x32 14 1/2"x12 1/2"	triangle 18x16 7"x6"	diamond 18x31 7"x12"
--------------------------------	-----------------------------	-------------------------------	----------------------------	-----------------------------	----------------------------------	---------------------------------	---	----------------------------	----------------------------

6 mm - PlayOne Mosaics*

mix mosaic 1.5x1.5 30x30 12"x12"	mix mosaic 3x3 30x30 12"x12"	mix mosaic 3x6 30x30 12"x12"	mix stripes mosaic 1.5x120 15x120 6"x48"	mix 3d mosaic 30x17 12"x6 1/2"
--	------------------------------------	------------------------------------	--	--------------------------------------

blend 20x20 / blend 15x60

20 pz	Rigato	Gesso	Crespo	Roccia	Scolpito
16 pz	Rigato	Gesso	Crespo	Roccia	Scolpito

6 mm

120x250 48"x100"	60x250 24"x100"	120x120 48"x48"	60x120 24"x48"	30x60 12"x24"
---------------------	--------------------	--------------------	-------------------	------------------

*Mosaici forniti su rete
Mosaics are mesh-mounted





Pavimento | Floor
Gesso Light
120x120 cm · 48"x48" +6 mm

Blend Light
20x20 cm · 8"x8" +6 mm

Parete | Wall
Mosaic 1.5x1.5 Mix Light
30x30 cm · 12"x12" +6 mm

Curtain Light 250
120x250 cm · 48"x100" +6 mm



Parete | Wall
Twill Light 250
60x250 cm · 24"x100" +6 mm

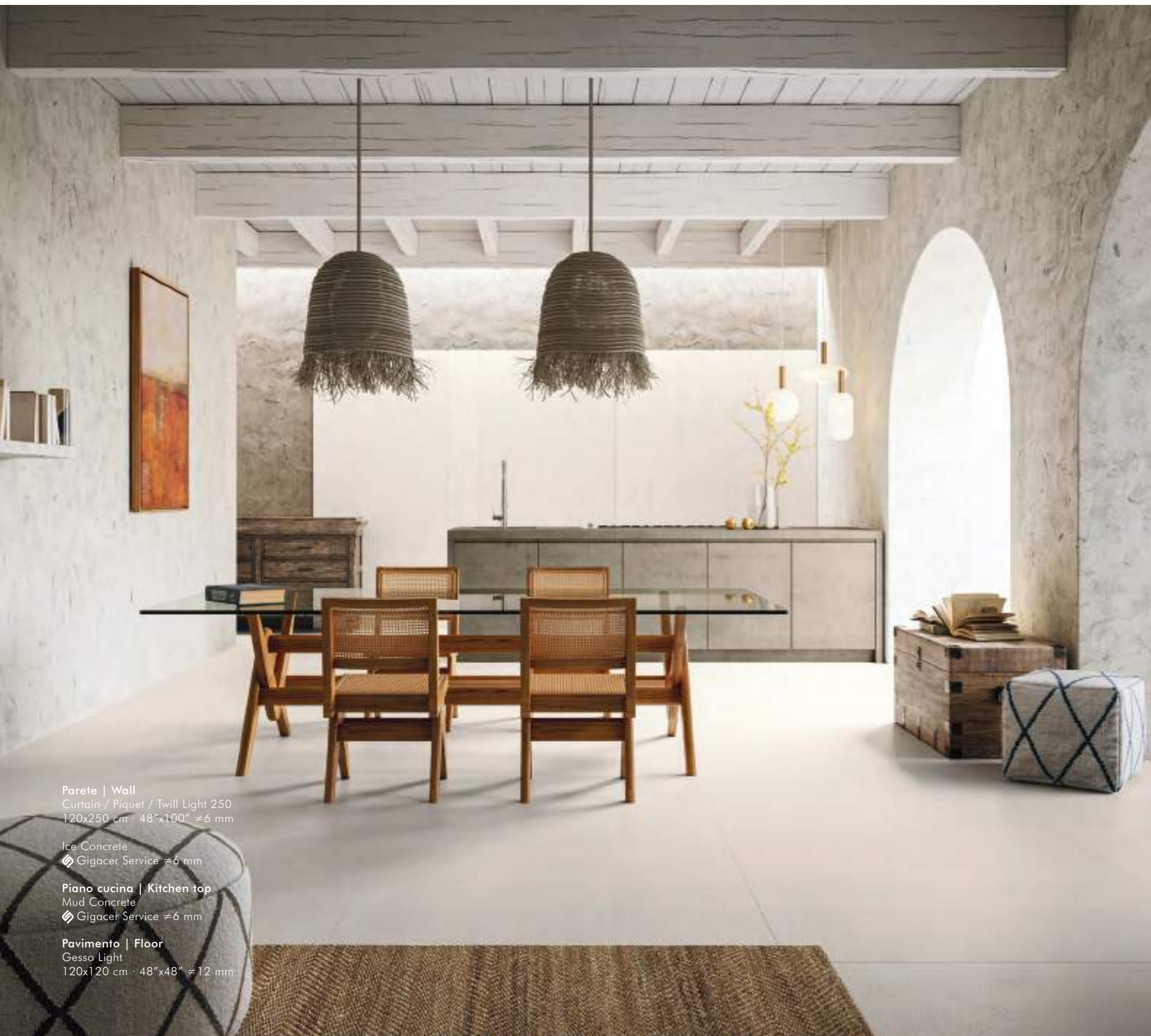

Parete | Wall
Curtain / Piquet / Twill Light 250
120x250 cm · 48"x100" ≈6 mm

Ice Concrete
Gigacer Service ≈6 mm

Piano cucina | Kitchen top
Mud Concrete
Gigacer Service ≈6 mm

Pavimento | Floor
Gesso Light
120x120 cm · 48"x48" ≈12 mm



Parete | Wall
Blend Light
20x20 cm · 8"x8" ≈6 mm

Pavimento | Floor
Blend Light
15x60 cm · 6"x24" ≈6 mm

Gesso Light
60x120 cm · 24"x48" ≈6 mm

Made 2.0

Made 2.0, in sinergia con Concrete (pag. 22), è un flessibile sistema ceramico a servizio degli spazi abitativi. È la paletta di combinazione colori/superfici più completa nelle tinte neutre e naturali: undici colori e quattro diverse superfici che si adattano alle diverse esigenze dell'abitare. Lo stesso colore può essere utilizzato dall'interno all'esterno, nei pavimenti e nei rivestimenti e per la realizzazione di piani cucina e mobili da bagno mantenendo una forte coerenza cromatica. Tutta la paletta Made 2.0 corrisponde ai colori Concrete. Il colore White Sand equivale al Concrete White.

Made 2.0, in synergy with Concrete (page 22), is a flexible ceramic system used for living spaces. It is the most complete color / surface combination palette in neutral and natural shades: eleven colours and four different surface that could be adapted to the different needs of living. The same colour could be used from the indoor to the outdoor, in floors and covering and for the creation of kitchen tops and bathroom furniture while maintaining a strong chromatic coherence. All the Made 2.0 Palette corresponds to the Concrete colours. The White Sand colour can be combined with the Concrete White.

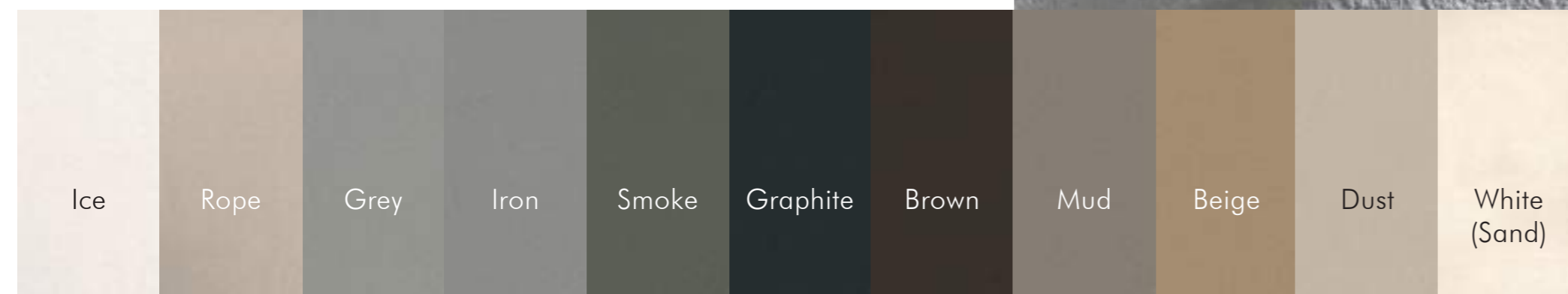

Made 2.0



Tutti i colori Made 2.0 corrispondono ai colori Concrete. Il colore White Sand si abbina al Concrete White.
 All Made 2.0 colours correspond to Concrete colours. Made White Sand matches Concrete White.

°Mix Concrete e Made 2.0 Bocciardato
 °Mix Concrete and Made 2.0 Bocciardato

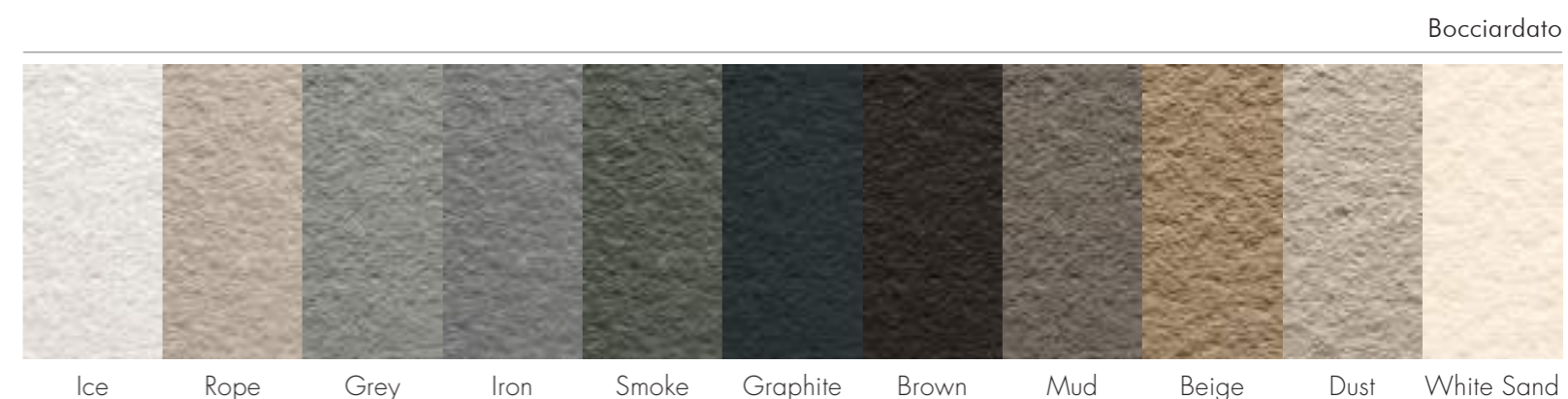
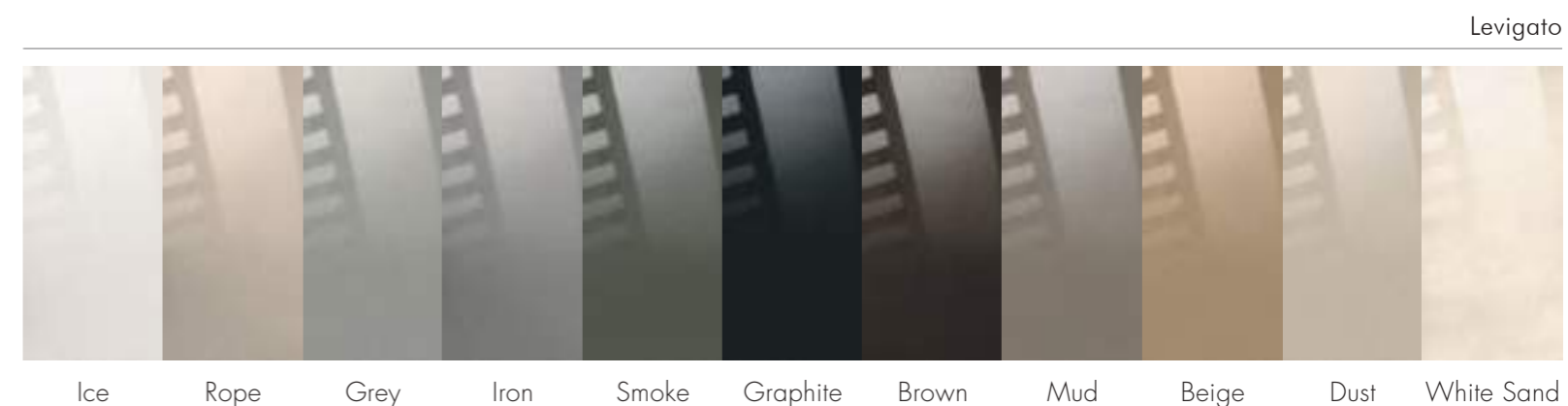
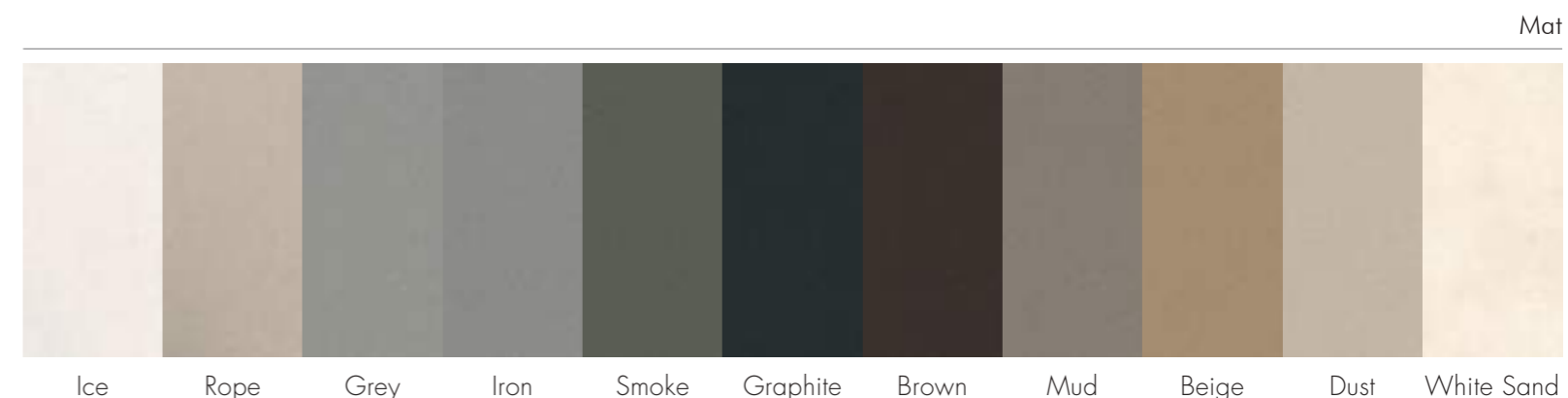
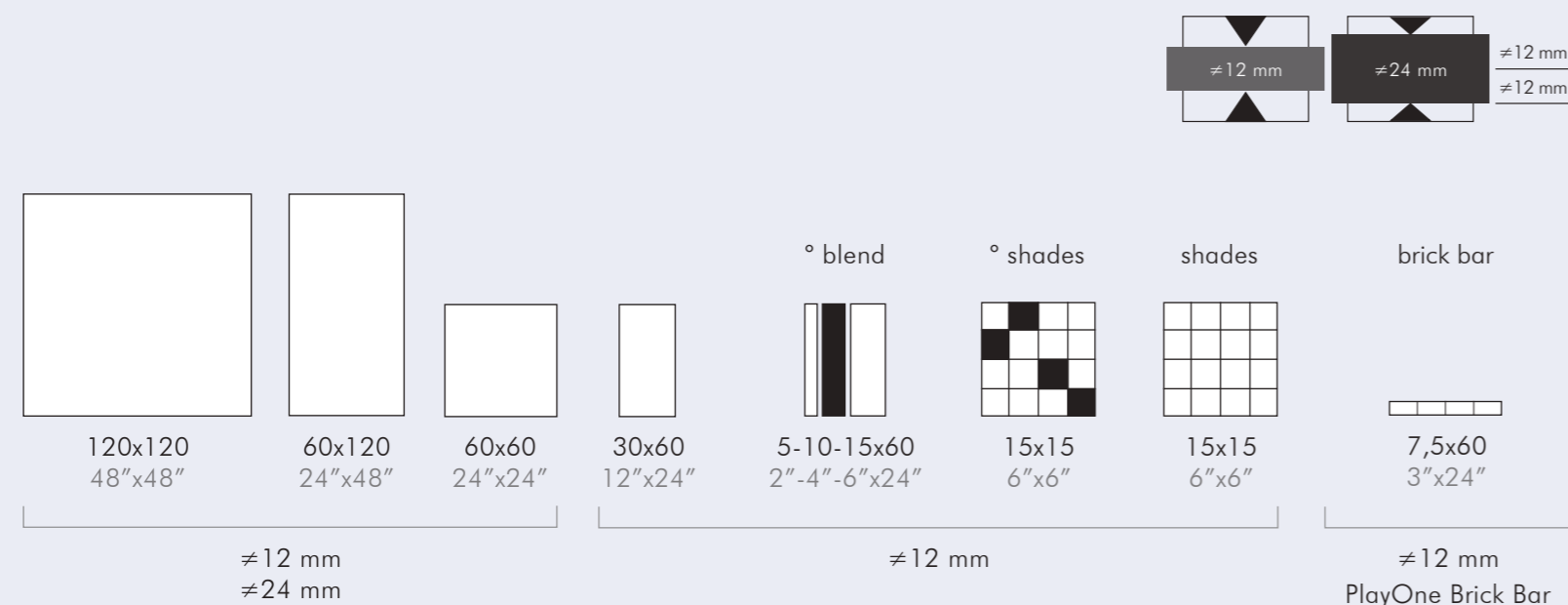

° Blend

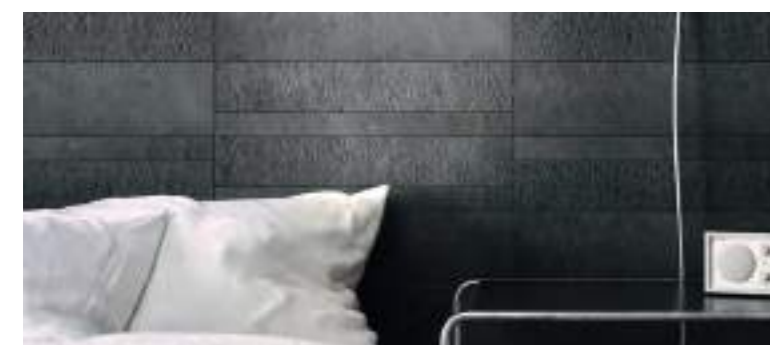

° Shades

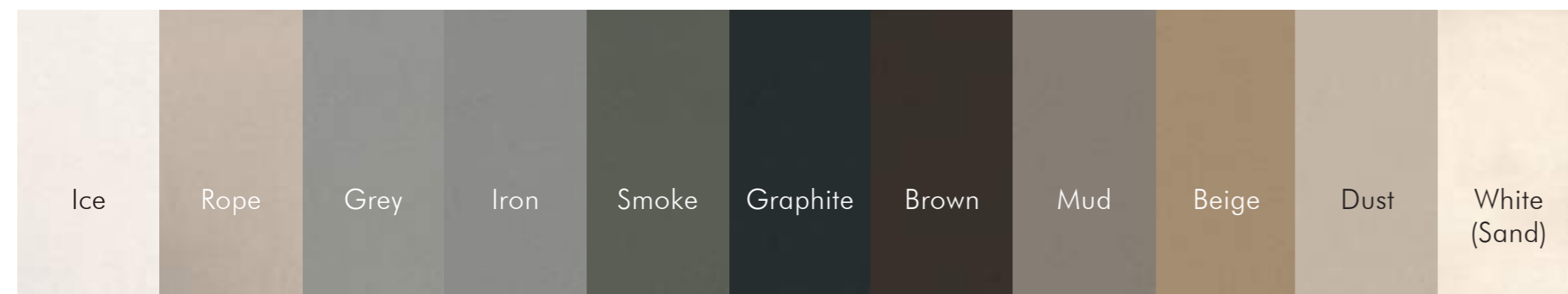



Parete | Wall
Mud Concrete / Bocciardato Made 2.0
Shades 15x15 cm · 48"x48" ≠ 12 mm

Mud Concrete
120x250 cm · 48"x100" ≠ 6 mm

Pavimento | Floor
Ice Bocciardato Made 2.0
120x120 cm · 48"x48" ≠ 12 mm



Pavimento | Floor
Ice Mat Made 2.0
120x120 cm · 48"x48" ≠ 12 mm



Scale | Stairs
Sand Bocciardato R11 Made 2.0
60x120 · 24"x48" ±12 mm



Pavimento | Floor
Graphite Bocciardato R11 Made 2.0
60x60 cm · 24"x24" ±12 mm

Quarry

Quarry reinterpreta in chiave tecnica la solida forza di sei pietre tipicamente europee. La prima pietra ispiratrice è la Quarzite Bianca, da cui prende il nome e il colore. Diffusa nelle catene montuose delle Prealpi, Arenaria interseca vene bianche al colore grigio. Gravel Stone richiama la pietra del Cardoso, le cui cave sono ubicate in prossimità del paese toscano. Lava Stone arriva dal Belgio, con una nuance scura. La Spagna è l'origine di Crema Marfil, una pietra dal colore beige a sfondo uniforme. Infine Golden Stone si ispira alla pietra fossile tedesca Solnhofen ed è proposta nel tono caldo del materiale originale.

Quarry reinterprets the solid power of six typically European stones in a technical way. The first stone inspiring us is Quarzite Bianca (white quartzite), the origin of its name and colour. Common in the Alpine foothills, Arenaria (sandstone) is grey in colour shot through with white veins. Gravel Stone brings to mind Cardoso stone with quarries near this Tuscan town. Lava Stone comes from Belgium and is dark. Spain is the origin of Crema Marfil, a homogeneous beige coloured stone. Lastly Golden Stone takes its inspiration from the Solnhofen German fossil stone and is offered in the warm hues of the original material.

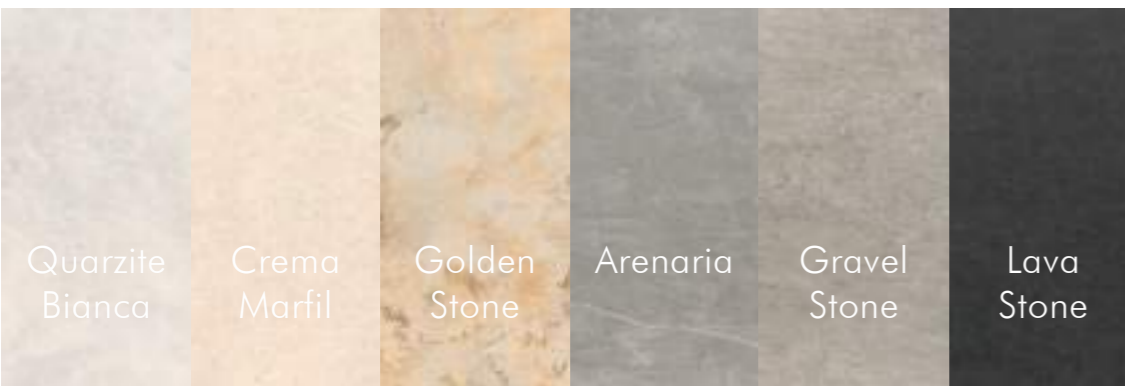

Quarry

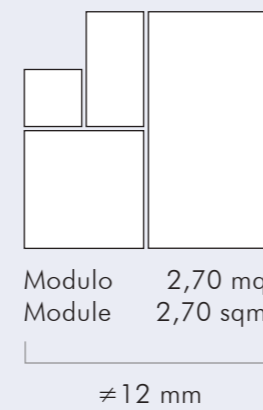
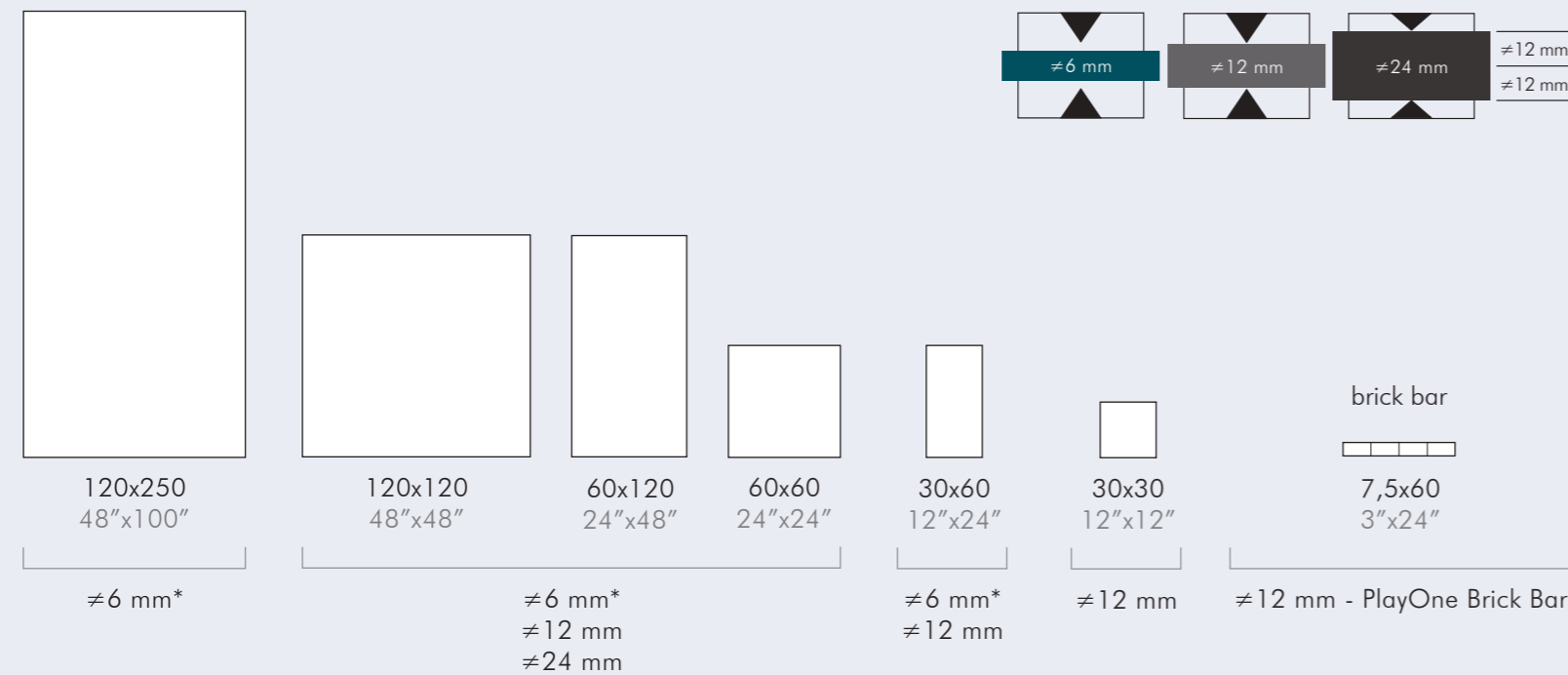

Ogni modulo, composto da 2 pezzi di 60x120, 2 pezzi di 60x60, 2 pezzi di 30x60 e 2 pezzi di 30x30, è contenuto in un'unica scatola. Each module, that is composed of 2 pieces of 60x120, 2 pieces of 60x60, 2 pieces of 30x60 and 2 pieces of 30x30, is packed in a single box.

*Disponibile nei colori solo nella superficie Mat: Available in colours only in the mat surface: Quarzite Bianca, Crema Marfil, Gravel Stone, Lava Stone.

**Mosaico Mix: Mat + Bocciardato Antiscivolo R11. Mosaico Mix: Mat + Bocciardato Antislip R11.

*** Disponibile solo in superficie Mat. Available only in Mat surface.

Tutti i colori e i formati sono disponibili in due finiture: Mat R10 A+B e Bocciardato antiscivolo R11 A+B+C.
All colours and sizes are available in two surfaces: Mat R10 A+B and Bocciardato antislip R11 A+B+C.

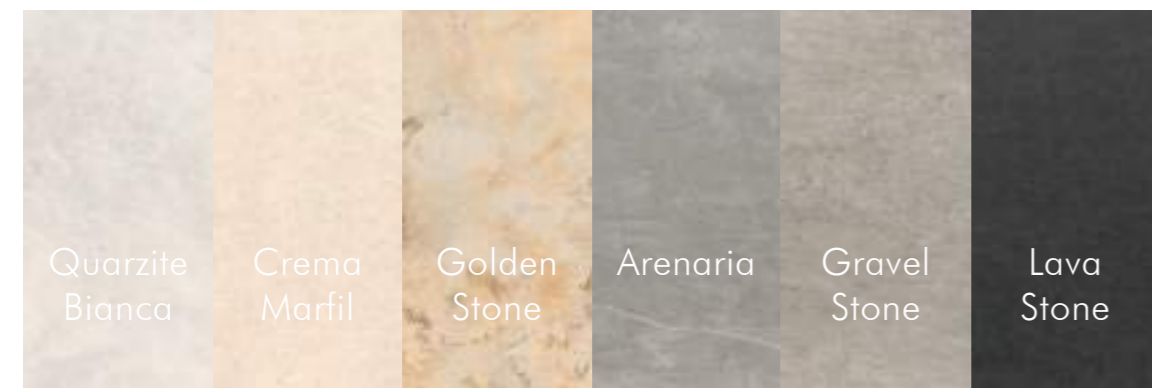
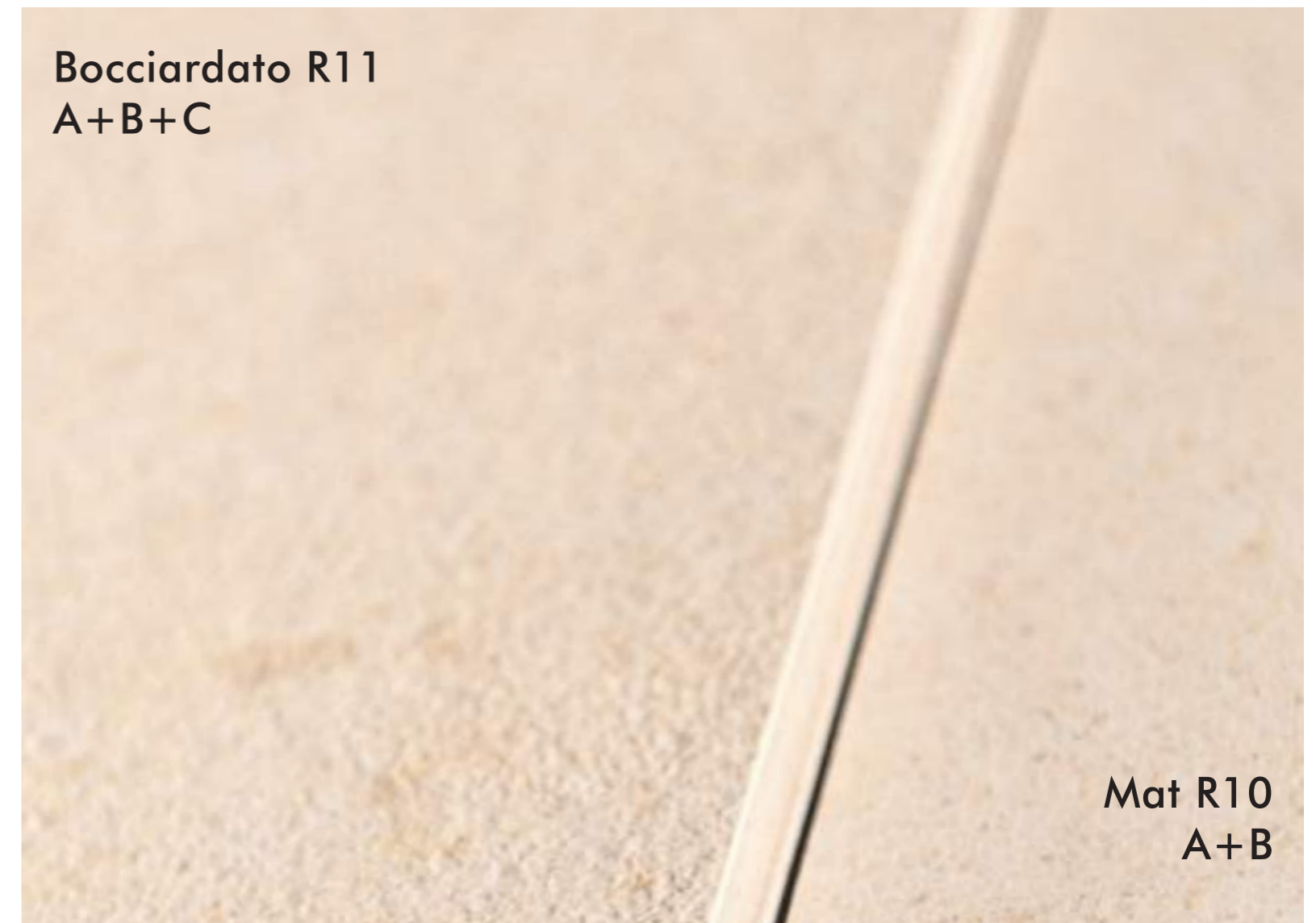

Mosaici forniti su rete
Mosaics are mesh-mounted



Pavimento | Floor
Arenaria Mat Quarry
Modulo/Module: 60x120 cm · 24"x48" · 60x60 cm · 24"x24" · 30x60 cm · 12"x24" · 30x30 cm · 12"x12" ≠12 mm

Arenaria Bocciardato R11 Quarry
120x120 cm · 48"x48" ≠12 mm



Pavimento | Floor
Gravel Stone Mat Quarry
120x120 cm · 48"x48" ≠12 mm

Quarzite Bianca Mat Quarry
120x120 cm · 48"x48" ≠12 mm

Parete | Wall
Gravel Stone Mat Quarry
120x250 cm · 48"x100" ≠6 mm

Quarzite Bianca Mat Quarry
120x250 cm · 48"x100" ≠6 mm



Parete | Wall
Golden Stone Mat Quarry
120x120 cm · 48"x48" ±12 mm

Pavimento | Floor
Golden Stone Bocciardato R11 Quarry
Modulo/Module:
60x120 cm · 24"x48" · 60x60 cm · 24"x24" · 30x60 cm · 12"x24" · 30x30 cm · 12"x12" ±12 mm



Pavimento | Floor
(Outdoor) Crema Marfil Bocciardato R11 Quarry
60x60 cm · 24"x24" ±12 mm

(Indoor) Crema Marfil Mat Quarry
120x120 cm · 48"x48" ±12 mm

Parete | Wall
Crema Marfil Mat Quarry
120x250 cm · 48"x100" ±6 mm

Camino | Fireplace
Lava Stone Mat Quarry
Gigacer Service ±6 mm

Tele

Geometrie dal fascino vintage e armoniose ispirazioni naturali. Una nuova linea dallo spirito artistico e dalla straordinaria espressività, capace di coniugare estetica e funzione. Grazie all'eloquenza dei decori, le nuove lastre "Tele" permettono di creare ambienti dalla forte connotazione, unici come opere d'arte. Eclettico e versatile, "Tele" completa e arricchisce la gamma Gigacer ed è facilmente abbinabile a prodotti dalle cromie più neutre, aprendo la strada ad innumerevoli soluzioni stilistiche e compositive.

Geometries with a vintage charm and harmonious natural inspirations. A new line with an artistic spirit and extraordinary expressiveness, able to combine aesthetics and function. Thanks to the eloquence of the decorations, the new "Tele" slabs allow to create settings with a strong connotation, as unique as works of art. Eclectic and versatile, "Tele" completes and enriches the Gigacer range and can be easily combined with products with more neutral colours, paving the way for countless stylistic and compositional solutions.

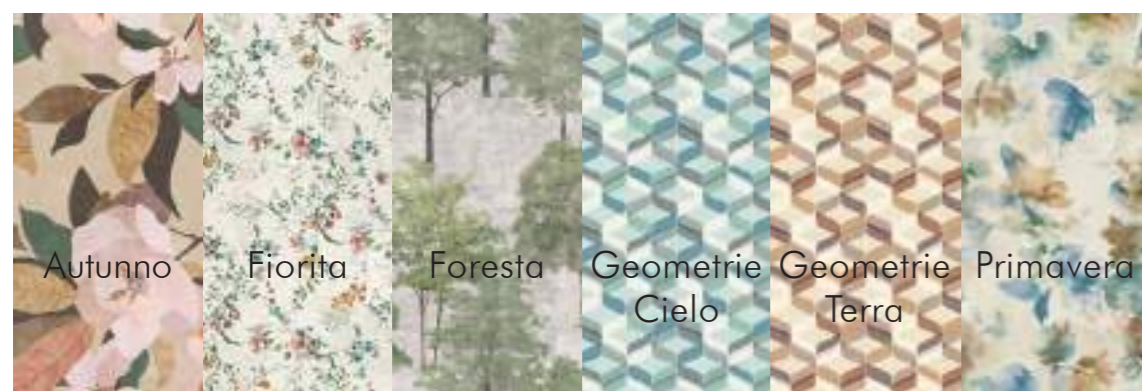

Tele

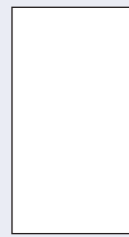

60x120
24"x48"

≠4.8 mm

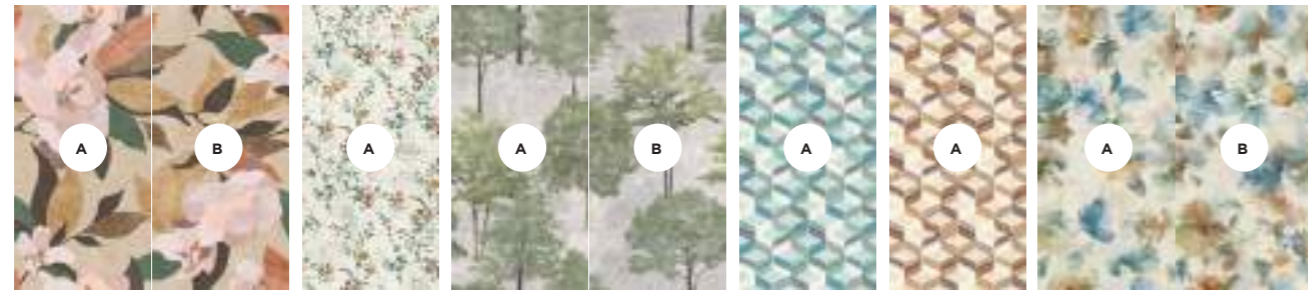

Autunno

Fiorita

Foresta

Geometrie
Cielo

Geometrie
Terra

Primavera

NOTE:

Autunno, Geometrie Cielo, Geometrie Terra sono decorazioni a freddo. Foresta, Primavera, Fiorita sono decorazioni a caldo.

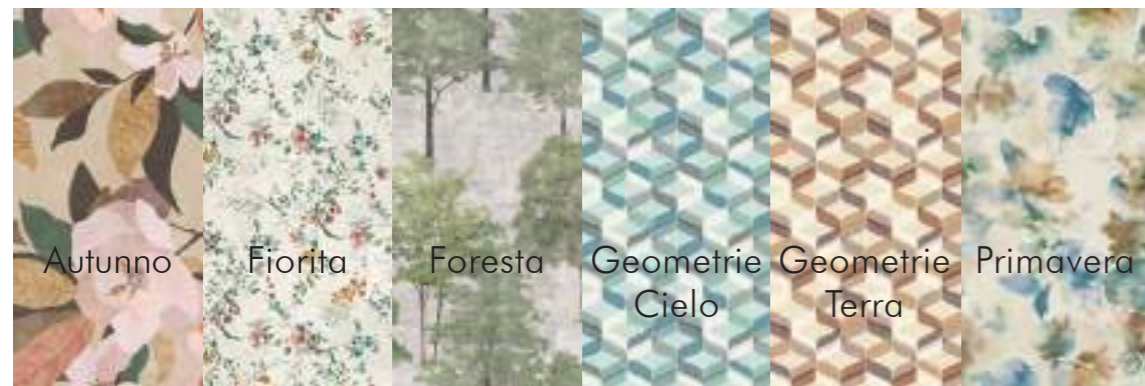

Autunno

Fiorita

Foresta

Geometrie
Cielo

Geometrie
Terra

Primavera



Parete | Wall
Foresta Tele
60x120 cm · 48"x100" ≠4.8 mm



Parete | Wall
Autunno Tele
60x120 cm · 24"x48" ≈4.8 mm

Pavimento | Floor
Graphite Concrete
120x120 cm · 48"x48" ≈4.8 mm



Parete | Wall
Geometrie Terra Tele
60x120 cm · 24"x48" ≈4.8 mm

Les Couleurs Suisse AG di Zurigo detiene i diritti in esclusiva mondiale sul sistema unico "Polychromie architecturale" di Le Corbusier e ha concesso a Gigacer Spa la licenza d'uso dei colori originali Les Couleurs® Le Corbusier sulle collezioni denominate LCS Ceramics, gres per l'architettura. LCS Ceramics è il primo sistema colore prodotto da Gigacer basato sulla Polychromie architecturale di Le Corbusier. Innovativi materiali in gres porcellanato ideati per pavimentare e rivestire l'architettura.

Les Couleurs Suisse AG of Zurich holds the exclusive international rights to Le Corbusier's unique "Polychromie architecturale" system and has granted Gigacer Spa the licence to use the original Les Couleurs® Le Corbusier colours in its collections LCS Ceramics, porcelain stoneware for architecture. LCS Ceramics is the first Gigacer colour system based on Le Corbusier's Architectural Polychromy. Innovative materials in porcelain stoneware for architecture.

Charles-Edouard Jeanneret-Gris, conosciuto con lo pseudonimo di Le Corbusier (1887-1965) è considerato il più importante architetto dell'era moderna. Ancora oggi le sue opere influenzano autorevolmente l'architettura e il design. Ha progettato moltissimi edifici e numerosi piani di sviluppo urbano in tutto il mondo, e oggi buona parte delle sue architetture sono state riconosciute dall'Unesco patrimonio dell'umanità. Le Corbusier ha lavorato in numerosi campi artistici dando vita ad una serie di opere quali dipinti, sculture, disegni e collage, smalti, arazzi, incisioni e oggetti d'arredo dal design inconfondibile, divenuti vere e proprie icone. Per Le Corbusier gli aspetti cromatici dei suoi edifici o dei suoi oggetti di design erano tanto importanti quanto la pianta e la forma. Affascinato dai colori equilibrati della natura, Le Corbusier diede vita alla "Polychromie architecturale" basandosi su una selezione progettuale e artistica di pigmenti.

Charles-Edouard Jeanneret-Gris, better known by the pseudonym Le Corbusier (1887-1965), is considered the most important architect of the modern age. His works still have a considerable influence on architecture and design today. He designed many buildings and drew up numerous urban development plans throughout the world and today the majority of his architecture has been recognised by Unesco as World Heritage. Le Corbusier was an all-round artist, producing a large number of artworks such as paintings, sculptures, drawings and collages, enamels, tapestries, engravings and furniture, all with the same unmistakable design and which have become real icons. The colour schemes of his buildings and design objects were just as important to Le Corbusier as the ground plan and shape. Fascinated by the balanced colours he found in nature, Le Corbusier based his "Architectural Polychromy" on a structured and artistic choice of pigments.

Le Corbusier

LCS Ceramics

Based on Le Corbusier's
Polychromie architecturale

A worldwide exclusive



/ LCS COLLECTIONS

Béton

LCS 1

Tokyo

Molitor

Pointillé

Béton

Il cemento in architettura.

Traendo ispirazione dai molteplici edifici di Le Corbusier circa l'utilizzo del cemento a vista, Gigacer ha realizzato Béton Gris e Béton Blanc, superfici in grès ceramico dai toni neutri che riprendono il carattere minimalista insito nel famoso Beton Brut. La gamma è ideale per utilizzi a pavimento e rivestimento di ambienti sia residenziali che pubblici e trova una naturale abbinabilità con i colori LCS Ceramics Le Corbusier.

Concrete in architecture.

Taking inspiration from the many buildings designed by Le Corbusier where he used exposed concrete, Gigacer has created Béton Gris and Béton Blanc, neutral ceramic porcelain surfaces which are reminiscent of the minimalist character of the famous Béton Brut. The range is ideal for wall and floor coverings for residential and public use and can be perfectly combined with the Le Corbusier LCS Ceramics colours.



Unité d'habitation - Marseille - 1945 ©



Blanc

Gris

Béton

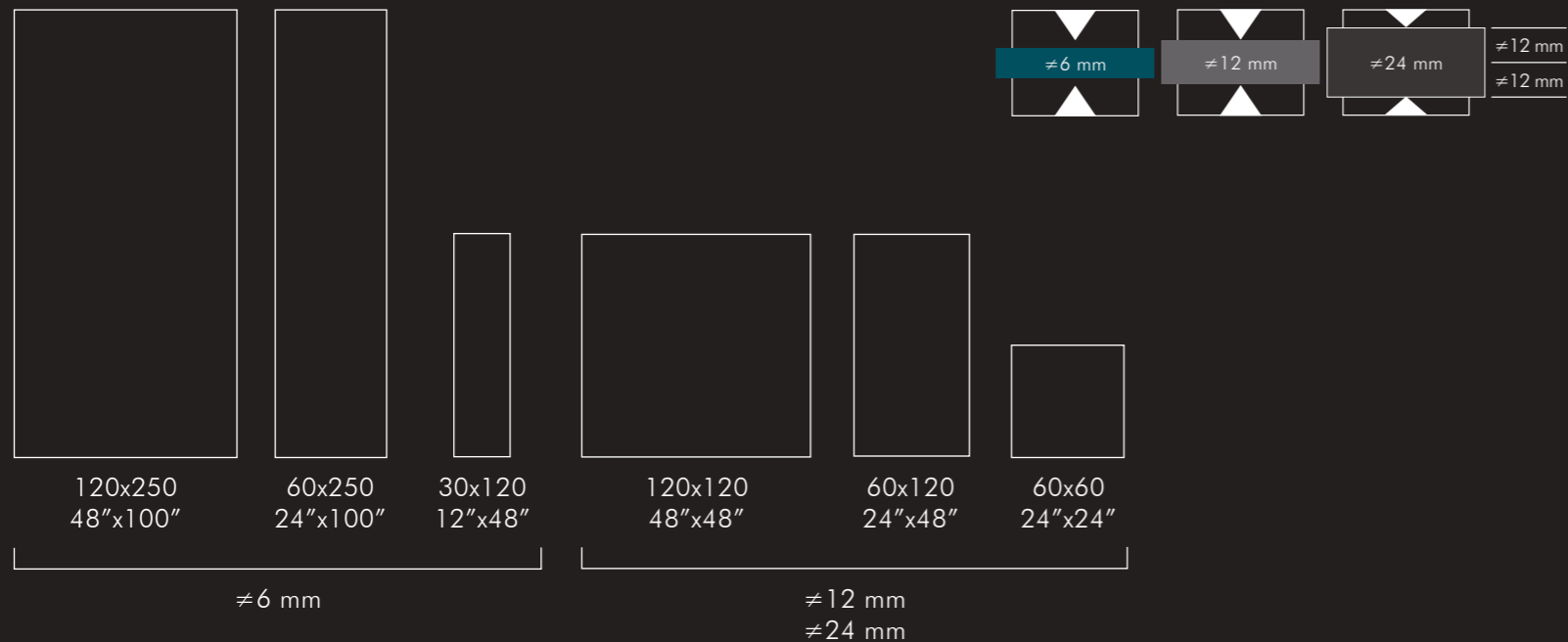

Blanc

Gris



Parete | Wall
4320E - Noir D'Ivoire - LCS1
30x120 cm · 12"x48" $\neq 6$ mm

Béton Gris
120x250 cm · 48"x100" $\neq 6$ mm

LCS 1

Gres porcellanato smaltato, lucido, brillante. Ideale per utilizzi a rivestimento in ambienti sia interni che esterni.

Glazed porcelain stoneware, glossy, brilliant. Ideal for indoor and outdoor wall coverings.



Maison des Jeunes et de la Culture - Firminy France - 1953 ©



32001
blanc

32013
gris clair 31

32020
bleu
outremer 31

32023
outremer pâle

32034
céruleen pâle

32123
terre sienne
pâle

32142
ombre
naturelle claire

4320A
rouge vermillon
59

4320B
blanc ivoire

4320E
noir d'ivoire

4320G
vert 59

4320W
le jaune vif

LCS 1 -glossy

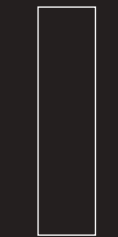

30x120
12"x48"

≠6 mm

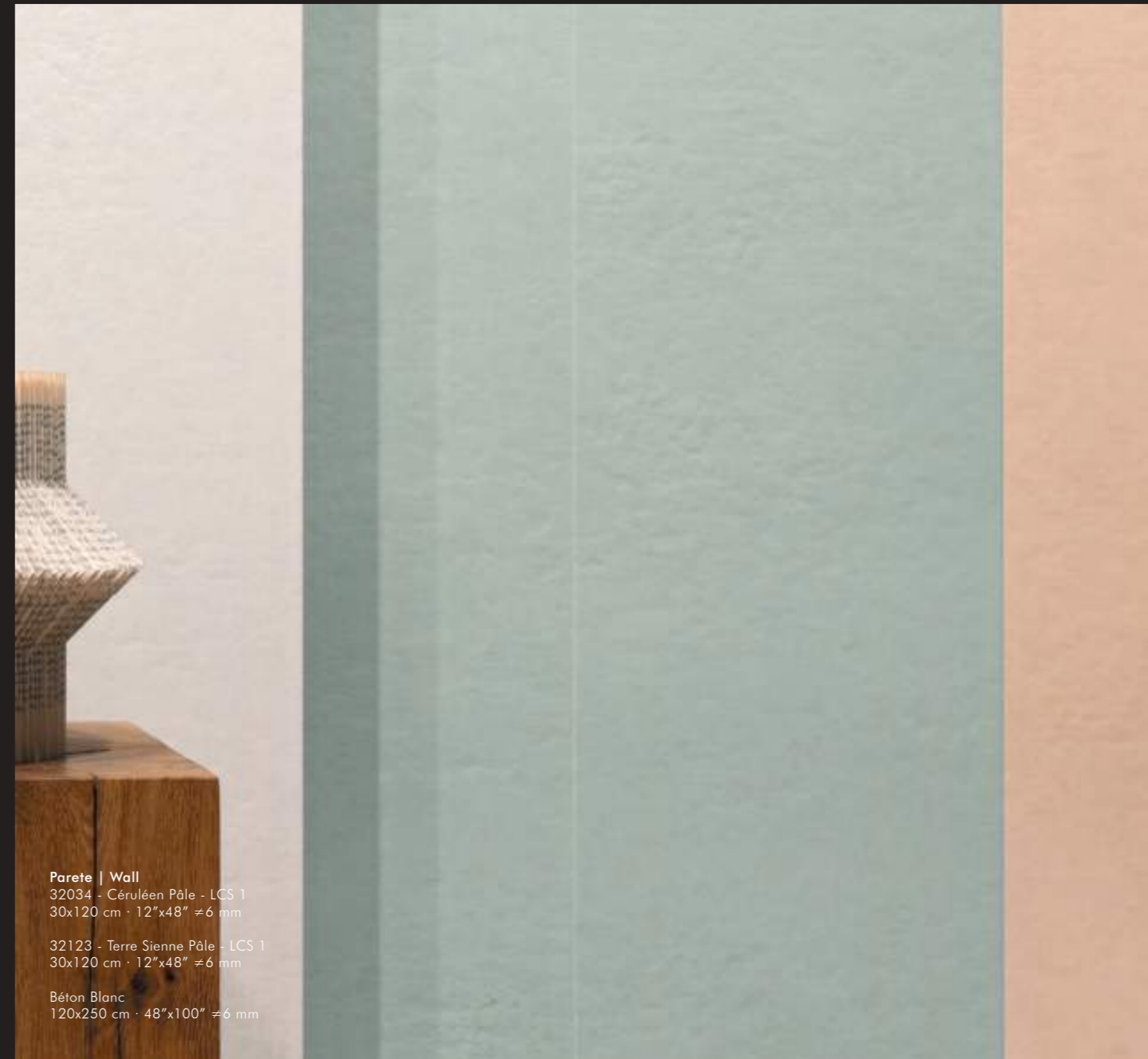

Parete | Wall

32034 - Céruléen Pâle - LCS 1
30x120 cm · 12"x48" ≠6 mm

32123 - Terre Sienne Pâle - LCS 1
30x120 cm · 12"x48" ≠6 mm

Béton Blanc
120x250 cm · 48"x100" ≠6 mm

32001
blanc

32013
gris clair 31

32020
bleu
outremer 31

32023
outremer pâle

32034
céruléen pâle

32123
terre sienne
pâle

32142
ombre
naturelle claire

4320A
rouge vermillon
59

4320B
blanc ivoire

4320E
noir d'ivoire

4320G
vert 59

4320W
le jaune vif

Tokyo

È l'unico esempio rappresentativo del lavoro di Le Corbusier in Estremo Oriente, e la recensione del New York Times sulla sua apertura suggeriva che l'edificio stesso presentava un "significato artistico e bellezza" che rivaleggiava con i dipinti all'interno. Il museo è a pianta quadrata con il corpo principale delle gallerie sollevate su "pilotis" al primo piano. Il layout è influenzato dal museo Sanskar Kendra di Le Corbusier ad Ahmedabad, progettato allo stesso tempo. Sulla facciata principale, Le Corbusier ha utilizzato blocchi di ghiaia cementata anziché calcestruzzo grezzo, e abbiamo tratto ispirazione da questa innovazione per sviluppare la nostra gamma Tokyo.

It is the only representative example of Le Corbusier's work in the Far East, and the New York Times review of its opening suggested that the building itself presented an "artistic significance and beauty" which rivaled the paintings inside. The museum is square in plan with the main body of the galleries raised on "pilotis" to first floor level. The layout is influenced by Le Corbusier's Sanskar Kendra museum in Ahmedabad which was being designed at the same time. On the main facade, Le Corbusier used blocks of cemented gravel instead of raw concrete, and we took inspiration from this innovation to develop our Tokyo range.



The National Museum of Fine Arts of the West - Tokyo - 1955 ©



Tokyo

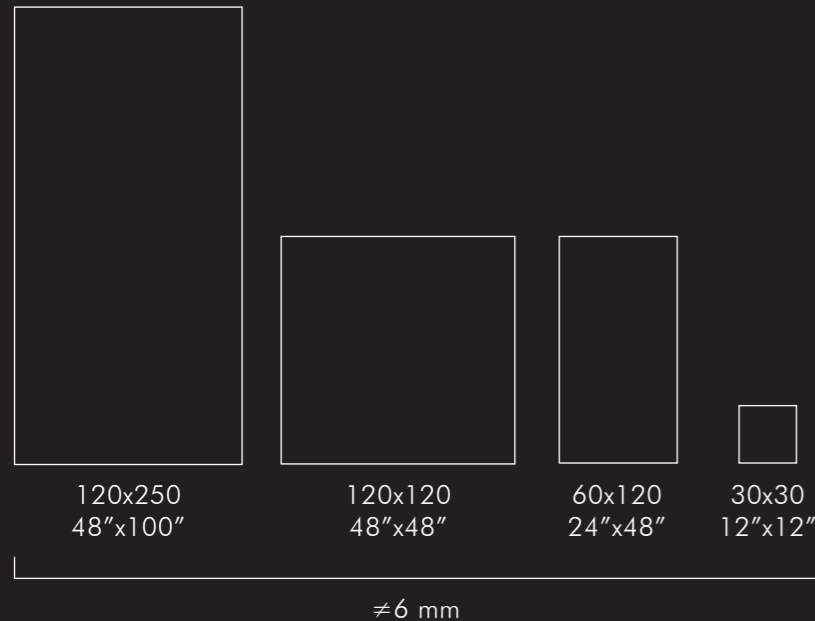

Mensola | Shelf
4320E - Noir d'Ivoire - Tokyo
Gigacer Service ≠6 mm



Molitor

Immeuble Molitor è un condominio progettato da Le Corbusier e Pierre Jeanneret e costruito tra il 1931 e il 1934. Situato al confine tra la città di Parigi e il comune di Boulogne-Billancourt in Francia, è stato elencato insieme ad altre 16 opere architettoniche di Le Corbusier come patrimonio mondiale dell'UNESCO. L'inventiva dell'architetto è evidente nelle facciate interamente in vetro. Identiche in entrambe le altezze, contemporanee alla Maison de Verre di Bernard Bijvoet, ma Le Corbusier partì dal prototipo di soli mattoni di vetrocimento con l'aggiunta di aperture trasparenti. Esternamente le facciate offrono un contrasto tra mattoni in vetro massiccio e finestre trasparenti, ma internamente gli appartamenti sono inondati di luce attraverso l'intera parete.

Immeuble Molitor is an apartment building designed by Le Corbusier and Pierre Jeanneret and built between 1931 and 1934. Located at the border between the city of Paris and the commune of Boulogne-Billancourt in France, it has been listed along with 16 other architectural works by Le Corbusier as a UNESCO World Heritage Site. The architect's inventiveness is evident in the all-glass facades. Identical on both elevations, contemporary to Bernard Bijvoet's Maison de Verre, but Le Corbusier departed from glass-brick-only prototype by the addition of transparent openings. Externally the facades offer a contrast between solid glass bricks and transparent windows, but internally the apartments are flooded with light across the entire wall.



Immeuble Molitor - Paris - 1934 ©



32140
ombre
naturelle 31

32141
ombre
naturelle
moyenne

32142
ombre
naturelle
claire

32013
gris clair 31

32011
gris 31

32010
gris foncé 31

Molitor

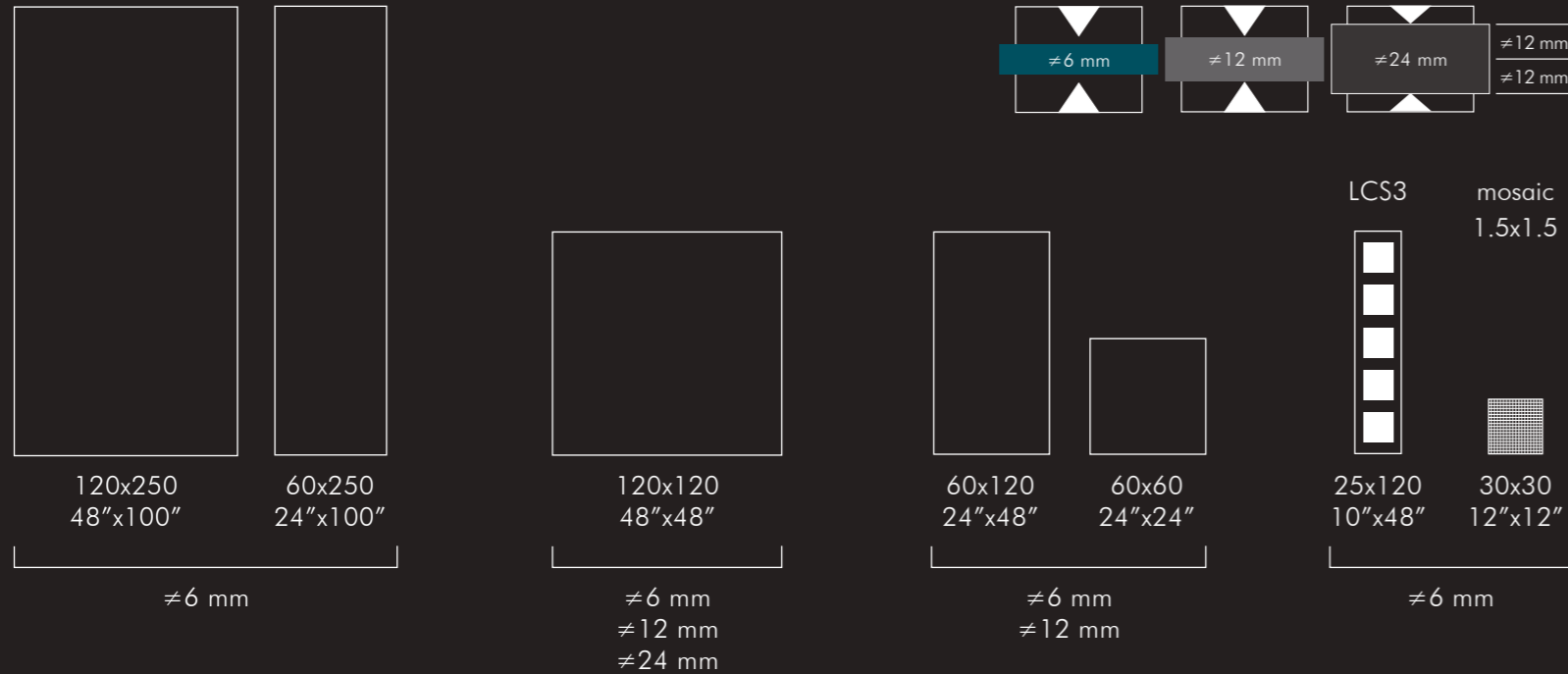

Pointillé

Pointillé è una reinterpretazione della carta da parati progettata da Le Corbusier per l'azienda svizzera Salubra, la stessa che diede inizio allo studio della Polychromie Architecturale. Pointillé è fedele allo spirito del maestro e utilizza la tecnologia contemporanea per riprodurre l'effetto sorprendente del colore a parete ricercato da Le Corbusier. Era il 1931 quando Le Corbusier creò il rivestimento per pareti basato su un motivo basilico quanto estemporaneo: il "puntino" tracciato allora ad olio su una tinta unita, per evitare che l'effetto di contrasto cromatico svanisse nel tempo per effetto della luce. La combinazione dei colori è rigorosamente tratta dalla Polychromie Architecturale.

Pointille is a reinterpretation of the wallpaper designed by Le Corbusier for the Swiss company Salubra, the same one that started the study of the Polychromie Architecturale. Pointille is faithful to the spirit of the Master and uses contemporary technology to reproduce the surprising effect of the wall color sought by Le Corbusier. It was 1931 when Le Corbusier created the wall covering based on a basic and extemporaneous motif: the "dot", later traced in oil on a solid colour base. This was made to prevent the effect of chromatic contrast fading away over time due to the effect of light. The combination of the colours is strictly taken from the Polychromie Architecturale.



Salubra Klaviers de Couleurs 1959 ©



32011
gris 31

32020
bleu
outremer 31

32042
vert anglais pâle

32142
ombre naturelle
claire

4320B
blanc ivoire

Pointillé

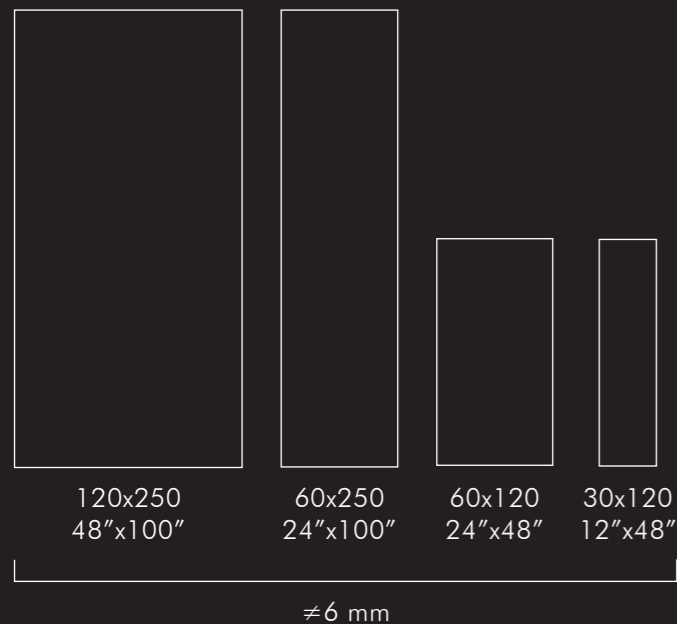
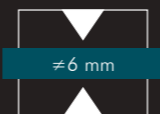

Parete | Wall
4320B - Blanc Ivoire - Pointillé
120x250 cm · 48"x100" ≠6 mm
32140 - Ombre Naturelle 31 - Molitor
60x250 cm · 24"x100" ≠6 mm



Parete | Wall
Béton Gris
120x250 cm · 48"x100" ±6 mm

4320E - Noir d'Ivoire - LCS 1
30x120 cm · 12"x48" ±6 mm

Pavimento | Floor
4320E - Noir d'Ivoire - Tokyo
120x120 cm · 48"x48" ±6 mm



Parete | Wall
Béton Blanc
120x250 cm · 48"x100" ±6 mm

32013 - Gris Clair 31 - LCS 1
30x120 cm · 12"x48" ±6 mm

Pavimento | Floor
32013 - Gris Clair 31 - Tokyo
120x120 cm · 48"x48" ±6 mm



Parete | Wall
Blanc Béton
120x250 cm · 48"x100" ≈6 mm

32042 - Vert Anglais Pâle - Pointillé
120x250 cm · 48"x100" ≈6 mm

Pavimento | Floor
Blanc Béton
60x120 cm · 24"x48" ≈12 mm



Parete | Wall
32011 - Gris 31 - Pointillé
120x250 cm · 48"x100" ≈6 mm

32010 - Gris Foncé 31 - Molitor
60x250 cm · 24"x100" ≈6 mm

Pavimento | Floor
4320E - Noir d'Ivoire - Tokyo
120x120 cm · 48"x48" ≈6 mm



Parete | Wall

32140 - Ombre Naturelle 31 - Molitor
120x250 cm · 48"x100" ≈6 mm

LCS3 32140 - Ombre Naturelle 31 - Molitor
25x120 cm · 10"x48" ≈6 mm

Pavimento | Floor

32140 - Ombre Naturelle 31 - Molitor
120x120 cm · 48"x48" ≈6 mm



Parete | Wall

32141 - Ombre Naturelle Moyenne - Molitor
120x250 cm · 48"x100" ≈6 mm

32142 - Ombre Naturelle Claire - LCS 1
30x120 cm · 12"x48" ≈6 mm

Pavimento | Floor

32141 - Ombre Naturelle Moyenne - Molitor
120x250 cm · 48"x100" ≈6 mm

Gigacer ha uno stile unico, per questo il matching fra i nostri prodotti viene spontaneo!

Nel progetto di gamma dell'azienda corre un filo conduttore che unisce e accomuna le collezioni. La ricerca è sempre rivolta all'autenticità e all'originalità delle proposte, che mantengono un'impronta contemporanea e la qualità tipica del miglior gres porcellanato. Si predilige uno stile neutro, con colori naturali; superfici adeguate ai diversi utilizzi domestici e pubblici, pensate per essere lo sfondo elegante e pratico su cui si dipanano le forme dell'abitare.

Gigacer offre una gamma molto ampia di formati, spessori, superfici e colori per progettare ogni tipo di ambiente: pavimenti e rivestimenti, spazi residenziali e commerciali, indoor e outdoor, mobili, facciate ventilate e piscine. Gigacer Matchings è un invito alla personalizzazione, lo strumento per trasformare uno spazio abitativo nel nostro personale spazio.

PlayOne, un articolato sistema di piccoli formati della gamma Gigacer, gioca un ruolo fondamentale all'interno di Gigacer Matchings. È l'espressione massima degli abbinamenti tra forme e colori. Lo spessore sottile permette sempre l'abbinamento con la grande lastra, invitando alla combinazione del grande con il piccolo, della superficie continua con il pattern decorativo. Il basso spessore di Gigacer è ideale sia per i pavimenti che per i rivestimenti, includendo al suo interno tutte le superfici orizzontali e verticali.

Gigacer's style is one of a kind. That's why our products match so naturally!

There is a common theme running through the firm's range design which all its collections have in common. The focus of its style is always authenticity and originality, a contemporary feel and the quality characteristic of porcelain stoneware. Its style of choice is neutral, in natural colours with surfaces suitable to all home and public space uses and designed to be a stylish and practical backdrop to any lifestyle choice.

Gigacer offers a very wide range of formats, thicknesses, surfaces and colours for all types of space: floor and wall claddings, residential and commercial spaces, indoor and outdoor, furniture, ventilated facades and swimming pools. Gigacer Matchings is an invitation to personalise, a tool with which to transform living areas into our very own personal spaces.

PlayOne, a complex small size Gigacer range system, plays a fundamentally important part in Gigacer Matchings. It is the ultimate in form and colour matching. Its limited thickness means it can always be combined with large slabs, facilitating large-small size and continuous surface-decorative pattern combinations. This low thickness also makes Gigacer ideal for both floor and wall claddings with all horizontal and vertical spaces covered.



PlayOne

Small Tiles More Design

presents

/ GIGACER MATCHINGS



Parete | Wall
 Vetiver Material Argilla
 60x120 cm · 24"x48" ≠6 mm

Vetiver Material Argilla
 Stripes Mosaic 1.5x120 - 15x120 cm · 6"x48" ≠6 mm

Curtain Light 250
 120x250 cm · 48"x100" ≠6 mm

Pavimento | Floor
 Vetiver Material Argilla
 120x120 cm · 48"x48" ≠6 mm

Vetiver Material Argilla
 Stripes Mosaic 1.5x120 - 15x120 cm · 6"x48" ≠6 mm



Parete | Wall
 Marine Material Argilla / Biacca Material Argilla
 Small Pentagon 17x10 cm · 7"x4" ≠6 mm

Top | Piano
 White Concrete
 Gigacer Service ≠12 mm

Pavimento | Floor
 Marine Quartz Argilla
 60x60 cm · 24"x24" ≠12 mm



Parete | Wall
Dark Material Argilla
Mosaic 3x6 30x30 cm · 12"x12" ≠6 mm

Pavimento | Floor
Fog Material Argilla
120x120 cm · 48"x48" ≠6 mm

Bancone | Counter
Graphite - Ice Concrete
Gigacer Service ≠12 mm

Piano dei tavolini | Counter top coffee
All colours Material Argilla
Gigacer Service ≠6 mm



Parete | Wall
Green Light Gatsby
120x250 cm · 48"x100" ±6 mm

Smoke - Ice Concrete
120x250 cm · 48"x100" ±6 mm

Pavimento | Floor
Dry Material Argilla
120x120 cm · 48"x48" ±6 mm



Parete | Wall
Old Yellow Gatsby
120x250 cm · 48"x100" ≠6 mm

Iron Concrete
120x250 cm · 48"x100" ≠6 mm

Pavimento | Floor
Iron Concrete
120x120 cm · 48"x48" ≠12 mm



Parete | Wall
Pure Concrete
120x250 cm · 48"x100" ≠6 mm

Arctic Déco
120x250 cm · 48"x100" - 60x250 cm · 24"x100" ≠6 mm

Pavimento | Floor
Vetiver Material Argilla
120x120 cm · 48"x48" ≠6 mm



Parete | Wall
Graphite Concrete
120x250 cm · 48"x100" ≠6 mm

Gesso / Rigato / Scolpito / Roccia / Crespo Light
Blend 20x20 cm · 8"x8" ≠6 mm



Pavimento | Floor
Ice Concrete / Graphite Concrete / Snow Krea
Diamond 18x31 cm · 7"x12" ≈4.8 mm

Ice Concrete / Graphite Concrete / Snow Krea
9x30 cm · 3 1/2"x12"
Gigacer Service ≈4.8 mm



Parete | Wall
Ice Concrete
120x250 cm · 48"x100" ≈6 mm

Pavimento | Floor
Gesso / Rigato / Scolpito / Roccia / Crespo Light
120x120 cm · 48"x48" ≈6 mm



Parete | Wall
Blue Krea
60x120 cm · 24"x48" ≈4.8 mm

Arctic Déco
120x250 cm · 48"x100" ≈6 mm

Pavimento | Floor
Silver Krea
120x120 cm · 48"x48" ≈12 mm

Lavabo left | left Washbasin
Blue Krea
120x50 cm · 48"x19 1/2"
Gigacer Service ≈4.8 mm



Parete | Wall
Tropic Déco
120x250 cm · 48"x100" - 60x250 cm · 24"x100" ≈6 mm

Brown Concrete
60x250 cm · 24"x100" ≈6 mm

Pavimento | Floor
Orange Krea
120x120 cm · 48"x48" - 60x120 cm · 24"x48" ≈4.8 mm

Brown Concrete
60x120 cm · 24"x48" ≈4.8 mm



Parete | Wall
Ivory Stone Mat Elementa
Large Hexagon 36x31 cm · 14"x12" ±6 mm

Ivory Stone Mat Elementa
Diamond 18x31 cm · 7"x12" ±6 mm

Ivory Stone Mat Elementa
Triangle 18x16 cm · 7"x6" ±6 mm

Pavimento | Floor
Ivory Stone Mat Elementa
Large Hexagon 36x31 cm · 14"x12" ±6 mm

Piano cucina | Kitchen top
Ash Mat Concept 1
Gigacer Service ±12 mm



Parete | Wall
Warm Stone Mat Elementa
120x250 cm · 48"x100" ±6 mm

Ecrù Mat Inclusioni Extrafine
60x250 cm · 24"x100" ±6 mm

Pavimento | Floor
Warm Stone Mat Elementa
120x120 cm · 48"x48" ±6 mm



Parete | Wall
Piquet Light 250
60x250 cm · 24"x100" ≠6 mm

Blend Light
15x60 cm · 6"x24" ≠6 mm

Beige Concrete
120x250 cm · 48"x100" - 60x250 cm · 24"x100" ≠6 mm

Pavimento | Floor
Gesso Light
120x120 cm · 48"x48" ≠12 mm

Beige Concrete
Mosaic1.5x1.5 - 30x30 cm · 12"x12" ≠4.8 mm



Parete | Wall
Twill Light 250
120x250 cm · 48"x100" ≈6 mm

Lavabo | Washbasin Double
Orange Krea
180x50 cm · 71"x19 1/2"
Gigacer Service ≈6 mm



Parete | Wall
Ground - Orange Krea
Small Hexagon 18x16 cm · 7"x6" ≈4.8 mm

Lavabo | Washbasin Double
Graphite Concrete
180x50 cm · 71"x19 1/2"
Gigacer Service ≈6 mm



Parete | Wall
Foresta Tele
60x120 cm · 24"x48" ≈4.8 mm

Pavimento | Floor
Ice Concrete
60x60 cm · 24"x24" ≈4.8 mm



Parete | Wall
Geometrie Cielo Tele
60x120 cm · 48"x100" ≈4.8 mm

Marine Material Argilla
60x120 cm · 24"x48" ≈6 mm

Pavimento | Floor
Grey Concrete
60x60 cm · 24"x24" ≈12 mm

Gigacer offre al professionista un'inedita gamma cromatica, che si abbina in modo trasversale all'importante sistema di formati, spessori e superfici pensati per ogni utilizzo in architettura:

- / Spazi residenziali e commerciali
- / Pavimenti e rivestimenti
- / Piani lavoro piena massa
- / Scale e pezzi speciali
- / Facciate ventilate
- / Pavimenti carrabili
- / Piscine & Spa

Gigacer offers the professional an unprecedented colour range that can be combined in multiple ways with the important system of shapes, thicknesses and surfaces designed for every use in architecture:

- / Residential and commercial spaces
- / Flooring and cladding
- / Through body worktops
- / Stairs and special pieces
- / Ventilated façades
- / Vehicle accessible flooring
- / Swimming pools & Spa

Indoor

Outdoor



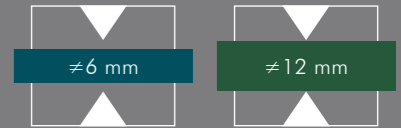

Le lastre in 12mm di spessore through body sono particolarmente indicate per il rivestimento di piani di lavoro, piani cucina, mobili da bagno. Il materiale viene prodotto utilizzando un solo strato di materiale prezioso, che attraversa la lastra fino al fondo, in modo che sia possibile lavorare i bordi come se fosse una pietra naturale, ma mantenendo tutte le caratteristiche migliorative del gres porcellanato tecnico non smaltato.

Our 12mm through body slabs are particularly indicated for countertops, kitchen tops and vanity tops. The material is manufactured by using one single layer of precious powders that runs through the body of the tile from the top to the bottom. This allows then to process the material as if it was a natural stone, by rounding and refining the edges, but keeping all the pluses of the technical porcelain stonewar.

LAVORAZIONI BORDI | EDGES MACHINING

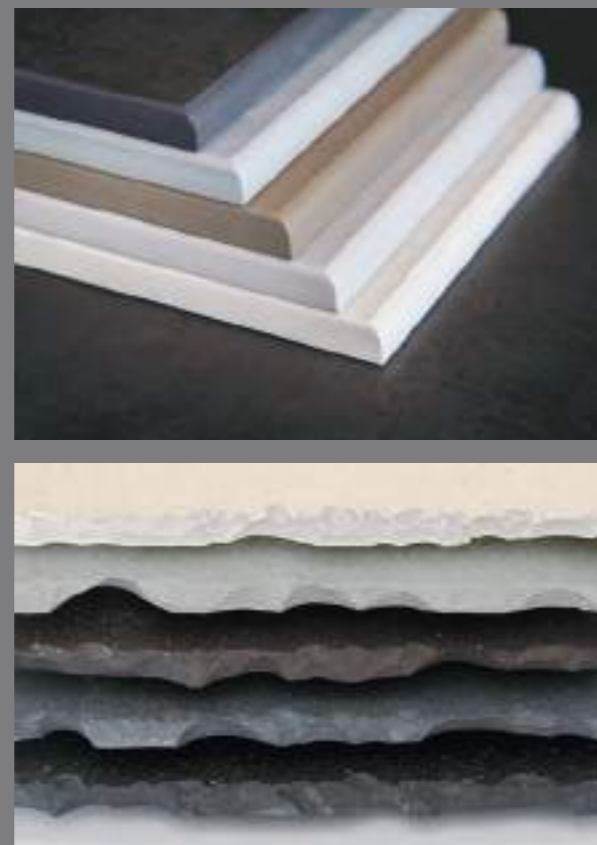
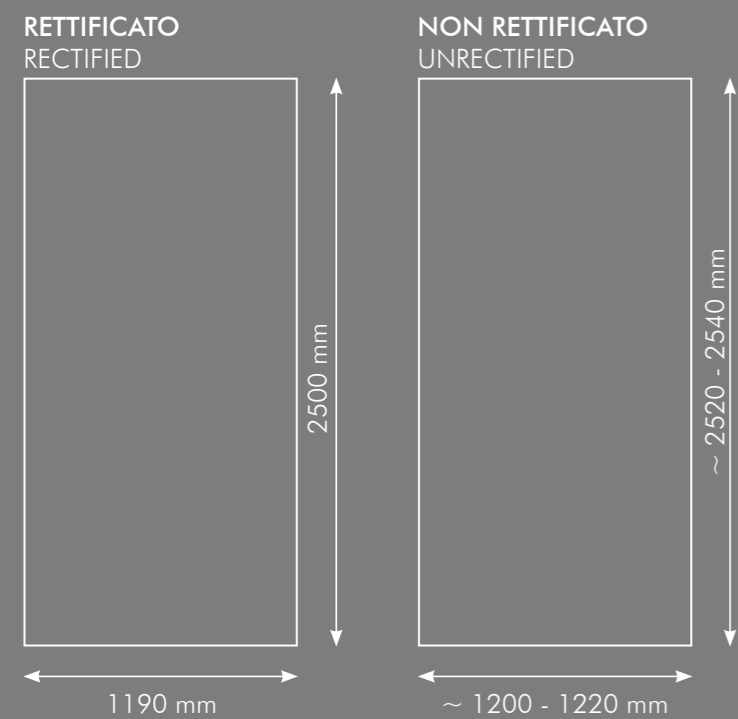
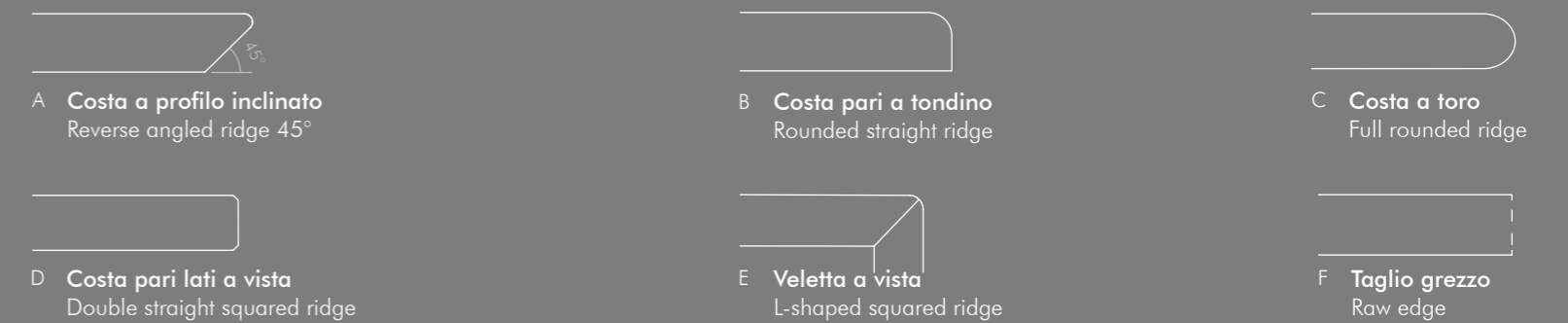

LAVORAZIONI TOP | WORKTOP MACHINING

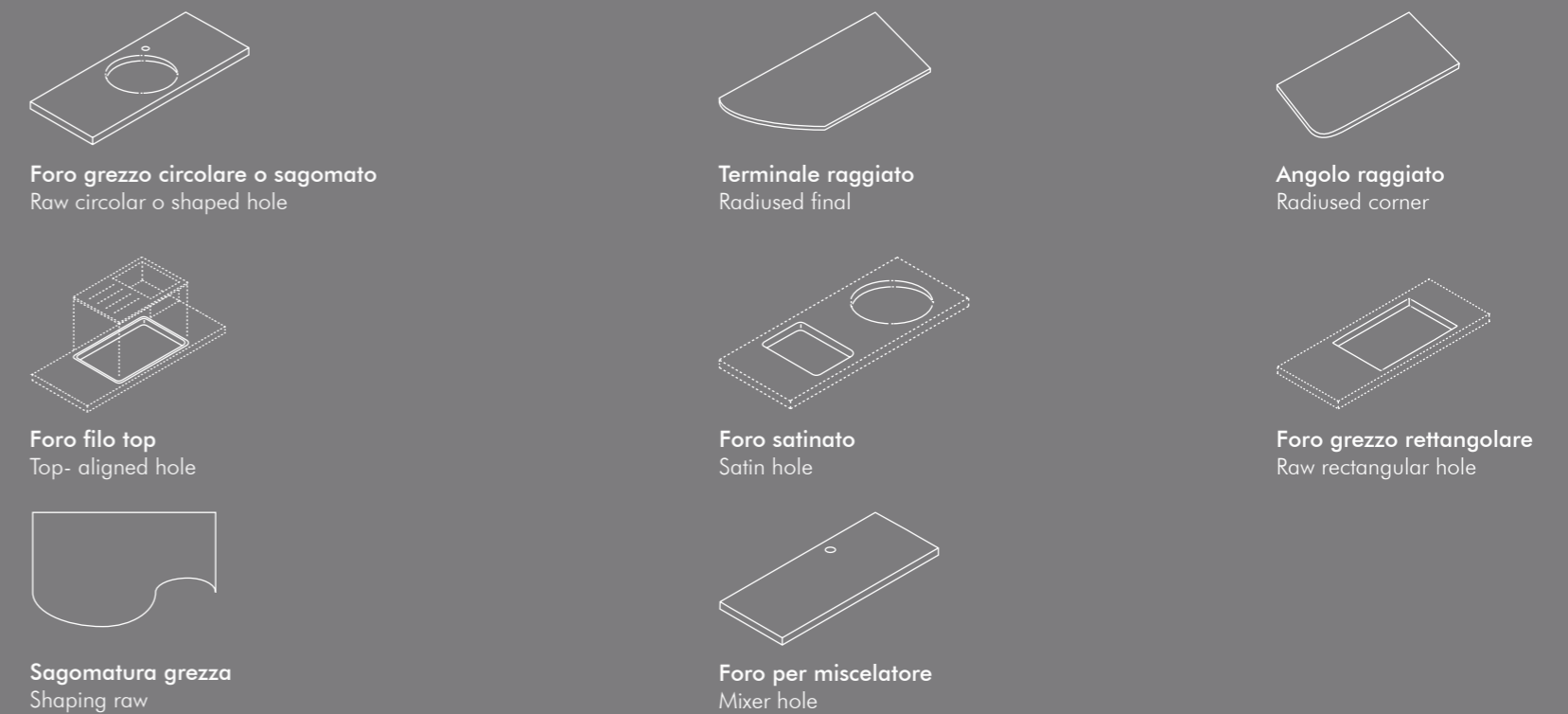

COLORI DISPONIBILI | COLOURS AVAILABLE:

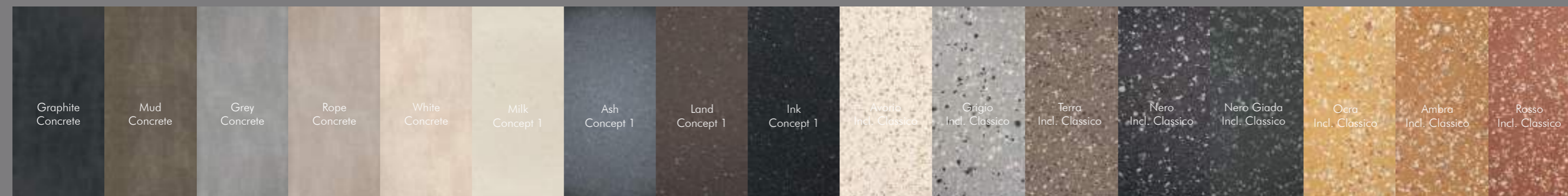

LAVABI | WASHBASINS

Middle

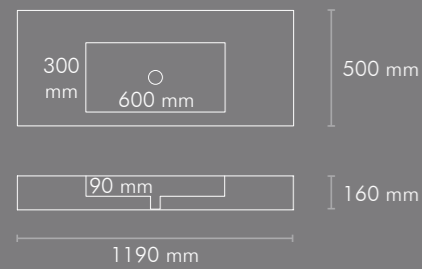

Tutti i colori in 4.8 e 6 mm.
All colours in 4.8 e 6 mm thickness.

Right

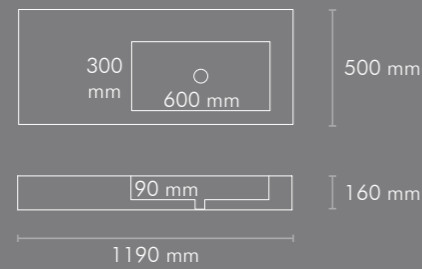

Tutti i colori in 4.8 e 6 mm.
All colours in 4.8 and 6 mm thickness.

Left

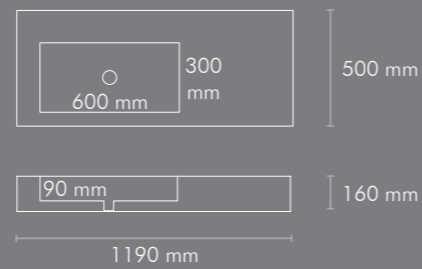

Tutti i colori in 4.8 e 6 mm.
All colours in 4.8 and 6 mm thickness.

Double

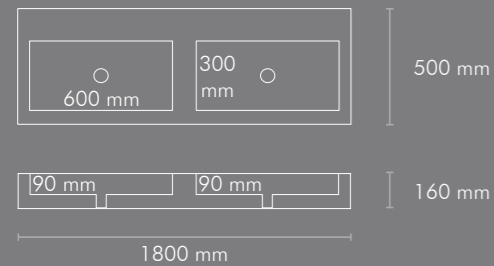

Tutti i colori in 6 mm nel formato 120x250 cm.
All colours in 6 mm thickness in 120x250 cm size.

Copertura vasca opzionale | Opzional basin cover

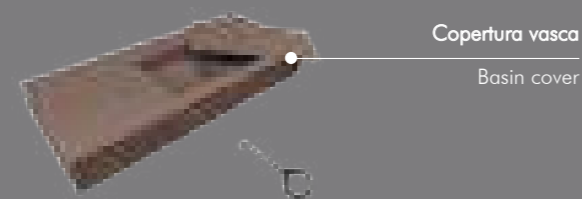

Staffe, piletta e sifone sono inclusi.
Brackets, drain and siphon are includes.



Tutte le informazioni tecniche inerenti ai lavabi le puoi trovare sulla brochure "Gigacer Service".
You can find all technical information about washbasins in our brochure "Gigacer Service".

Per dimensioni o spessori diversi da quelli rappresentati in tabella contattare Gigacer Service.
For inquiries concerning different thicknesses and sizes from the ones indicated in the table, please contact Gigacer Service.

PIATTI DOCCIA | SHOWER TRAYS

Modello A

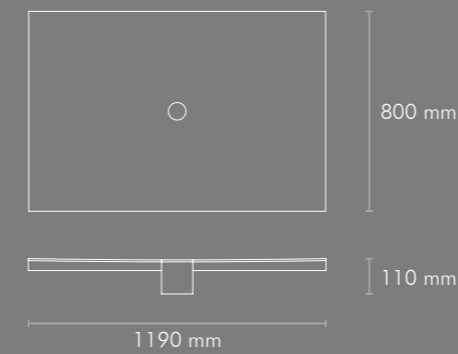

Tutti i colori in 4.8 e 6 mm.
All colours in 4.8 and 6 mm thicknesses.

Modello B

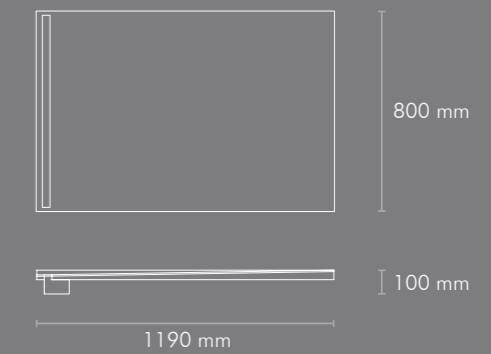

Tutti i colori in 4.8, 6 e 12 mm.
All colours in 4.8, 6 and 12 mm thicknesses.



Sono inclusi canalina o piletta.
Drain channel or drain are includes.



Tutte le informazioni tecniche inerenti ai piatti doccia le puoi trovare sulla brochure "Gigacer Service".
You can find all technical information about shower trays in our brochure "Gigacer Service".

Per dimensioni o spessori diversi da quelli rappresentati in tabella contattare Gigacer Service.
For inquiries concerning different thicknesses and sizes from the ones indicated in the table, please contact Gigacer Service.



Gigacer Service è il servizio di lavorazioni su misura offerto da Gigacer su tutti i suoi prodotti. Consente di tagliare, forare, lucidare e in generale adattare le lastre al singolo progetto, seguendo le indicazioni di uno specifico disegno del cliente. In questo modo le lastre ceramiche possono essere utilizzate sia per realizzare elementi d'arredo, sia per personalizzare o adeguare al progetto le dimensioni di lastre per pavimento o rivestimento. Il pavimento o il rivestimento potrà così essere abbinato o addirittura identico al top cucina, ai gradini della scala, al top bagno o anche allo stesso lavabo, in una infinità possibilità di forme e dimensioni. Il pezzo unico viene realizzato anche seguendo le indicazioni e il disegno tecnico del progettista.

Gigacer Service is the firm's made to measure working service offered on all products. It enables slabs to be cut, perforated, polished and generally adapted to the individual project in line with the requisites of a specific client design. In this way the ceramic slabs can be used both to create decor elements and to personalise or adjust slab dimensions to flooring or decor designs. In this way the ceramic slabs can be matched with, or even identical to, the kitchen worktop, flights of steps, the bathroom worktop and even the basin in an infinity of possible forms and dimensions. Each single piece can be made in accordance with designers' instructions and technical drawings.



BATTISCOPIA | SKIRTING

Battiscopa 60
≠ 12mm

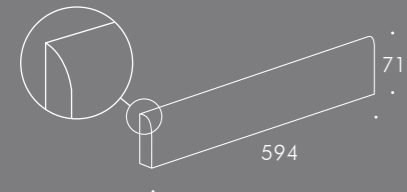

Battiscopa 120
≠ 4.8mm

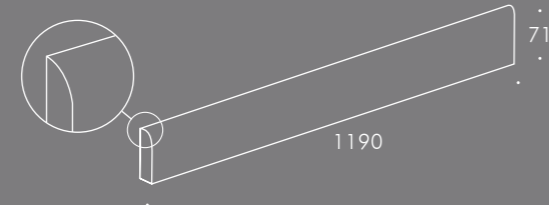

Battiscopa 120
≠ 6mm

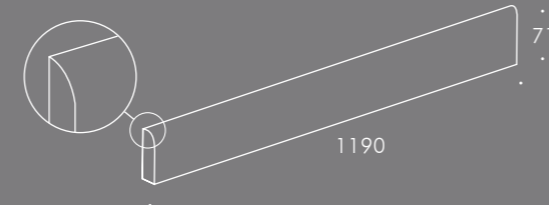

Utilizzo: pezzi di finitura che consentono di proteggere la parte bassa della parete durante le quotidiane operazioni di pulizia.
Dettagli: La parte superiore del battiscopa 12mm viene arrotondata e smaltata a freddo per nascondere gli strati del multilayer. I battiscopa 4.8mm, 6mm e 12mm su materiale a piena massa, non necessitano di smaltatura.

Use: finishing pieces that protect the lower part of the walls during everyday cleaning and maintenance operations.
Details: the top of the 12mm thickness skirting pieces is cold glazed to hide the layers of the multilayer porcelain. 4.8, 6, 12mm skirtings are not glazed on the nose, as they are made of through body porcelain.

GRADONI VELA | VELA STEPTREADS

Vela 120

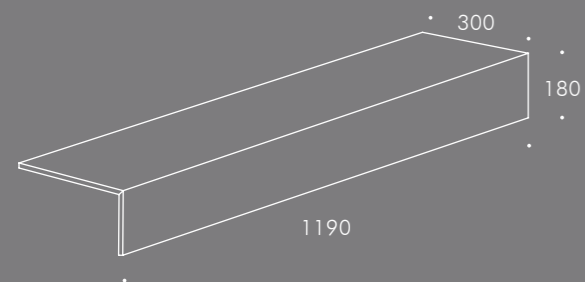

Utilizzo: gradini per scale.

Use: stepreads for stairs.

GRADONI COSTA RETTA | COSTA RETTA STEPTREADS

Costa retta 60

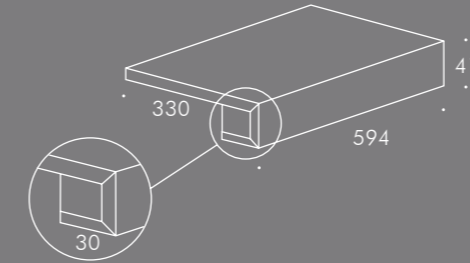

Costa retta 120

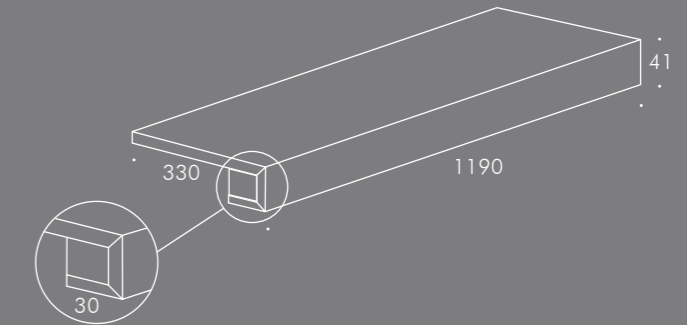

Utilizzo: gradini per scale, davanzali, finitura terrazze e balconi, bordo piscine, interno o esterno.

Use: stepreads for stairs, windowsills, terraces and balconies edge finish, poolside, indoor or outdoor.

MODIFICHE SU RICHIESTA | CHANGES ON REQUEST



È possibile richiedere la fattibilità e la quotazione per le seguenti modifiche:
1- top squadrato invece che arrotondato
2- top non smaltato (nel 12mm sarà visibile il multilayer)
3- misure non standard: indicare misura X e Y in mm

It is possible to require the feasibility and the quotation for the following changes:
1- squared top edge, instead of rounded
2- unglazed top edge (on 12mm thickness the multilayer will be visible)
3- bespoke sizes: please indicate X and Y in mm

Le misure X, Y, Z e J sono modificabili a piacimento.
È possibile richiedere il gradone con chiusura su un lato o su entrambi, nel caso la scala sia aperta.
Il pezzo può essere realizzato anche a vela senza rientranza.
È necessario indicare tutte le misure richieste (X, Y e Z).

It is possible to request bespoke sizes on X, Y, Z and J.
It is possible to ask for one or both sides closed, if the staircase is open.
The piece can be made without nose, only at 90°.
All sizes must be specified (X, Y and Z).

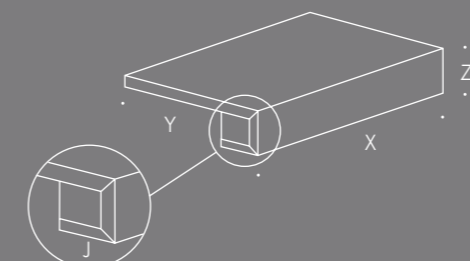
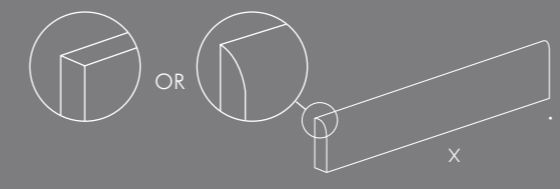



DESTINAZIONI D'USO | INTENDED USE CLASSIFICATION

	Pavimenti nuove costruzioni New floors	Pavimenti in ristrutturazioni Floor renovation	Rivestimenti Wall covering	Commerciale leggero Light commercial	Commerciale pesante Heavy commercial	Esterni Outdoor	Soprelevato Raised floor	Piani di lavoro Countertops kitchentops
4.8 mm 6 mm	+	++	++	+	--	-	--	-
12 mm multilayer	++	+	+	++	++	+	+	-
12 mm through body	-	-	-	-	-	-	-	++
20 mm 24 mm	-	-	-	-	++	++	++	-
	Posa a terra in nuove costruzioni sumassetto Floor tiling on screed in new buildings	Posa a terra su pavimenti esistenti, in ceramica o pietra naturale, o su massetto in costruzioni in stato di ristrutturazione Floor tiling on screed or on existing floor (in ceramic or natural stone) in buildings under renovation	Rivestimento muri Wall covering	Ambienti pubblici interni a medio traffico Indoor public places subject to medium pedestrian traffic	Ambienti pubblici interni ad alto traffico Indoor public places subject to heavy pedestrian traffic	Ambienti esterni Outdoor places	Pavimenti soprelavati con struttura flottante o posa su supporti in PVC Raised floor with floating structure or PVC supports	

SUGGERIMENTI PER LA POSA | INSTALLATION SUGGESTIONS

Le lastre di 4.8 mm e 6 mm sono: resistenti, sottili, leggere, facili da movimentare e da tagliare, resistenti al fuoco, ingelive, ecocompatibili e non necessitano di particolari accorgimenti per la manutenzione. È un prodotto ideale per pavimenti e rivestimenti ed è particolarmente adatto nel caso di ristrutturazione di pavimentazioni e rivestimenti residenziali: si applica sull'esistente senza opere di demolizione e relativi costi di smaltimento. Il nostro porcellanato sottile è abbinabile ai pavimenti della stessa collezione in spessore tradizionale, dei quali mantiene non solo le stesse caratteristiche estetiche, ma anche il medesimo calibro e modularità. Il 4.8 mm / 6 mm è un prodotto dal design ecologico: lo spessore ridotto comporta un minor impatto ambientale in termini di consumo di energia, materie prime, imballo e trasporti. Costituisce una valida alternativa al gres porcellanato di spessore tradizionale in tutti i casi in cui il minor spessore e la leggerezza costituiscono un fattore determinante. In fase di posa, le lastre di spessore 4.8 mm e 6 mm risultano perfettamente complanari.

SUGGERIMENTI PER LA POSA

INCOLLAGGIO: Doppia spalmatura (sul fondo e sul retro della piastrella)
 TAGLIO: Normale taglierina da cantiere, sega a dischi diamantati.
 FORATURA: trapani a punta per gres porcellanato, frese a tazza, idrogetto.
 Non usare il percussore e raffreddare con acqua nel punto di contatto.

4.8mm and 6mm slabs are resistant, thin, lightweight, easy to handle and cut, fire-resistant, frostproof, environmentally friendly and require no special care for maintenance. 4.8 mm / 6 mm is an ideal product for cladding. 4.8 mm / 6 mm slabs are particularly suitable in the case of renovation of residential floors and walls: they can be laid on the existing floor, allowing for a dramatic demolition and disposal cost savings. GIGACER 4.8 mm is suitable for indoor and outdoor wall covering and it is particularly indicated in all cases where it is preferable not to load too much weight on the building's structure. 4.8mm/6mm can be combined with the 12 mm slabs of every collection because it has the same caliber and it is perfectly modular with 2 mm joints. 4.8 mm / 6 mm is a green product: it allows savings in terms of energy consumption, raw materials, packaging and transport. It is a valid alternative to the traditional 12 mm in all those cases where lightness and less thickness represent a determinant variable.

4.8 mm and 6 mm tiles can be fixed together on the same surface, as the real difference in thickness is minimal.

INSTALLATION SUGGESTIONS

GLUING: Double spreading (on substrate and on the back of the tile).
 CUTTING: Standard dry diamond clipper for porcelain tiles, bench machines with diamond disks.
 DRILLING: Drills with porcelain drill tips, hollow mills or hose-mounted drill bits (for large size holes), hydrojet.
 Never use the hammer function when drilling.

- ++ Consigliato | Recommended
- + Appropriato | Suitable
- Non consigliato | Not recommended
- Non appropriato | Not suitable

Il sistema del 20 mm / 24 mm e la speciale superficie antiscivolo R11 A+B+C garantiscono elevate prestazioni tecniche e notevole sicurezza per l'uso all'aperto. Il sistema del 20 mm è ingelivo, inassorbente, facile da pulire, ha un'altissima resistenza agli urti, all'abrasione e alle aggressioni chimiche.

20 mm / 24 mm system and the special antislip R11 A+B+C surface guarantee high technical performances as well as remarkable safety for outdoor use. 20 mm system is frostproof, inabsorbent, easy to clean, has very high resistance to impact, abrasion and to chemical aggressions.

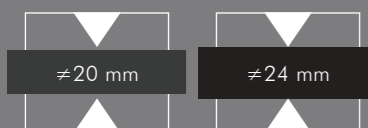

Antislip R11 A + B + C



1 Posa a colla tradizionale
Laying on glue

2 Posa a secco su ghiaia
Dry installation on gravel

3 Posa a secco su erba
Dry installation on grass

4 Pavimento sopraelevato
Polypropylene supports



PIEDINI IN POLIPROPILENE | POLIPROPYLENE SUPPORTS

120x120 · 48"x48"
9 pz/lastra
9 pcs/slab

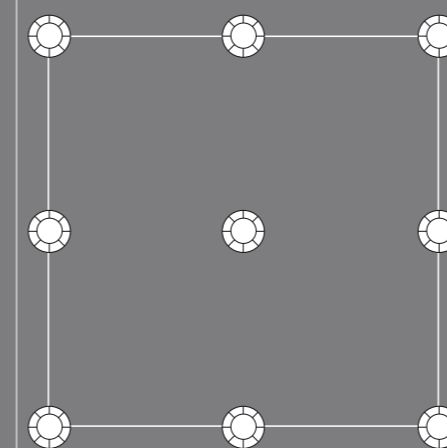

60x120 · 24"x48"
6 pz/lastra
6 pcs/slab

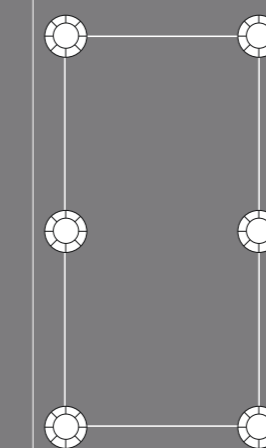

60x60 · 24"x24"
4 pz/lastra
4 pcs/slab

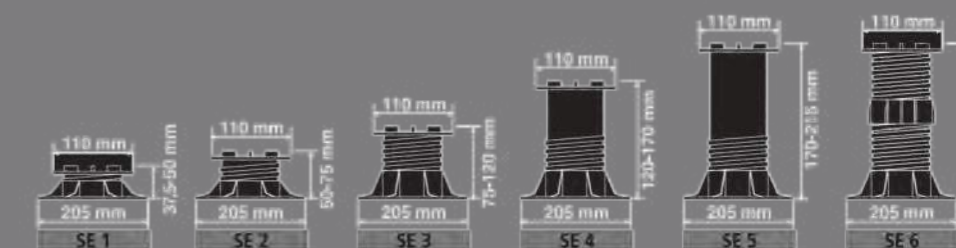
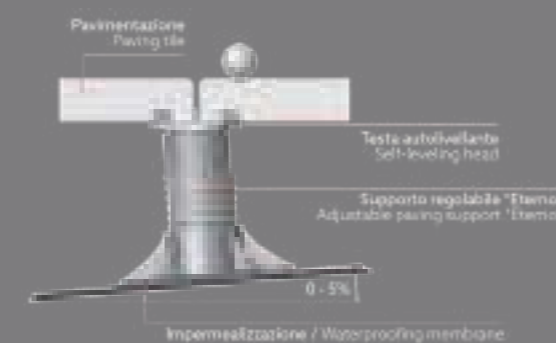
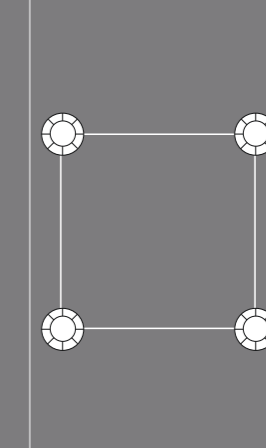

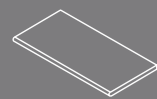
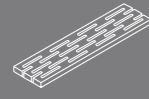
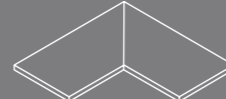
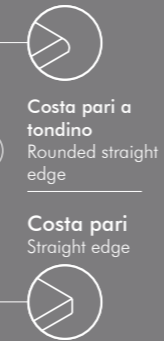

PEZZI SPECIALI PER L'ESTERNO | OUTDOOR SPECIAL TRIMS

GRADINO COSTA
TORO
BULLNOSE30x60
12"x24"GRIGLIA
GRID15x60
6"x24"GRIGLIA AD ANGOLO
ANGLE GRID15x60
6"x24"ANGOLO INTERNO
INTERNAL CORNER30x60
12"x24"ANGOLO ESTERNO
OUTSIDE CORNER30x60
12"x24"

La resistenza di 2 lastre di 12mm di spessore, incollate assieme con colla speciale garantisce uno sforzo di rottura di $\geq 20000 \text{ N}^{**}$. $\approx 24\text{mm}$ è resistente al gelo, ha un altissimo carico di rottura, è resistente ai sali, facile da pulire anche utilizzando idropulitrici, resistente agli attacchi di muffe, funghi, muschi e trattamenti al verderame. È rimovibile, riutilizzabile, antiscivolo, resistente al fuoco e facile da installare. $\approx 24\text{mm}$ non cambia col tempo e resiste a tutte le condizioni climatiche, caratteristiche fondamentali per un pavimento esterno. La posa può essere fatta utilizzando diverse tecniche, secondo il tipo di superficie da ricoprire. Le lastre possono essere installate a secco direttamente su ghiaia, sabbia o altri substrati, possono essere stese su supporti sopraelevati (es. Eterno Ivica Pedestal) o incollate. L'installazione sopraelevata può essere effettuata con una struttura portante di moduli in polipropilene, che possono essere fissi, regolabili e autolivellanti. Hanno una altezza minima di 37,5 mm e massima di 230 mm. L'installazione sopraelevata consente una facile ispezione di cavi o condutture senza dover rompere il pavimento. $\approx 24\text{mm}$ pavimento sopraelevato è la migliore soluzione per luoghi residenziali o commerciali come balconi, vialetti, ecc. dal momento che protegge la superficie sottostante e consente ogni tipo di intervento tecnico. Consigliamo una fuga di 4mm per lo scolo dell'acqua.

The strength of 2 12mm thick tiles glued together with a special glue grants a breaking strength of $\geq 20000 \text{ N}^{**}$. $\approx 24\text{mm}$ is frostresistant, has a very high breakage load, it is resistant to salts, easy to clean also using pressure washers, resistant to the attack of mould, moss and verdigris treatments, removable, reusable, anti-slip, fire-resistant and very easy to install. $\approx 24\text{mm}$ does not change and lasts over time in any climatic conditions, characteristics that are a must for outdoor floor coverings. Installation can be done using different techniques, according to the kind of surface. The porcelain stoneware slabs can be laid using a dry installation system, directly onto gravel or sand substrates as well as with raised installation (i.e. Eterno Ivica Pedestals) or glued. Raised installation is made with a support structure made of polypropylene, prefabricated, load-bearing modules, which can be fix, adjustable and self levelling. They have a minimum height of 37,5mm and a Maximum height of 230mm. Raised installation allows for easy inspection of underlying cabling and circuits without the need for burdensome work. $\approx 24\text{mm}$ raised floor is the best solution for residential and commercial destinations such as balconies, paths, access floors, etc., Protecting the under-space and easily allowing any kind of technical intervention. A 4 mm joint is requested for water drainage.

I VANTAGGI DEL 24MM | THE ADVANTAGES OF 24MM

- Possibilità di avere un prodotto con lo stesso tono e superficie posato nelle aree interne ed esterne
- Grande formato 120x120 in 24mm di spessore
- Possibilità di avere un pavimento antiscivolo all'esterno con posa facilitata
- Drenaggio efficace
- Posa a secco
- Durata e resistenza
- Pulibilità
- Ingelività

Lo stucco del bordo del 24mm è colorato in tinta con il fondo scelto.
Esempi di utilizzo del 24mm: pavimento sopraelevati / terrazzi all'aperto / terrazze chiuse / vialetti esterni / facciate ventilate / spiagge piscine / piatti doccia.

- Possibility to have a product with the same tone and surface for indoor and the outdoor spaces
- Big format 120x120 24 mm thickness
- Possibility to have an antislip material for the outdoor with easy lay
- Efficient drainage
- Dry laying
- Endurance and strength
- Cleanability
- Frost resistance

The grout in the 24mm thickness has the same colour of the tiles.
Some examples using 24mm: raised access floors / open terraces / closed terraces / walkways / swimming pools / gardens / shower trays.



POSA E COLLA | INSTALLATION AND ADHESIVES

IL SUPPORTO

Il massetto o il substrato deve essere sufficientemente resistente a sopportare il peso aggiuntivo previsto con l'installazione del pavimento in ceramica, deve essere perfettamente planare, perfettamente maturo (da 28 giorni di presa o secondo indicazioni del produttore del cemento) e libero da qualsiasi detrito o liquido sulla superficie (polvere, sabbia, terra, olio, vernice, grasso, ecc.) che possa compromettere l'adesione della ceramica al supporto.

SUPPORTI IN CEMENTO RINFORZATO

Il supporto deve essere maturo, pulito, asciutto e libero da qualsiasi sostanza che possa compromettere l'adesione della ceramica al substrato. Ogni crepa formatasi a seguito del restringimento idrometrico del supporto deve essere sigillata con adesivo bicomponente epossidico (es. EPORIP di Mapei spa o simili). Se il supporto presenta tracce di polvere o sporco deve essere pulito accuratamente e successivamente deve essere applicato uno strato di primer in resina monocomponente con contenuto di componenti organici volatili (VOC) molto basso (es. PRIMER G o ECO PRIM T di Mapei spa o simili). Se la superficie del cemento presenta parti scrostate o indebolite è necessario consolidarle con un primer epossidico o in poliuretano mono o bicomponente (come PRIMER MF o ECOPRIM PU 1K di Mapei spa o simili).

MASSETTI

Il massetto deve essere maturo (28 giorni di presa o secondo indicazioni del produttore del cemento), pulito, asciutto e libero da qualsiasi sostanza che possa compromettere l'adesione della ceramica al substrato. Ogni crepa formatasi a seguito del restringimento idrometrico del supporto deve essere sigillata con adesivo bicomponente epossidico (es. EPORIP di Mapei spa o simili). Una volta che la superficie è completamente liscia e matura è necessario controllare che abbia la resistenza necessaria a sopportare le sollecitazioni e il peso ai quali sarà sottoposta con la posa della ceramica. Se il supporto presenta tracce di polvere o sporco deve essere pulito accuratamente e successivamente deve essere applicato uno strato di primer in resina monocomponente con contenuto di componenti organici volatili (VOC) molto basso (es. PRIMER G o ECO PRIM T di Mapei spa o simili). Se la superficie del cemento presenta parti scrostate o indebolite è necessario consolidarle con un primer epossidico o in poliuretano mono o bicomponente (come PRIMER MF o ECOPRIM PU 1K di Mapei spa o simili). Per pavimenti riscaldati deve essere eseguito il corretto ciclo del sistema in conformità con le norme vigenti e le indicazioni del produttore del sistema di riscaldamento a pavimento.

PAVIMENTI ESISTENTI IN CERAMICA, COTTO O PIETRA

Per il fissaggio delle lastre su pavimenti esistenti controllare per prima cosa che il pavimento esistente sia ancora solidamente attaccato al substrato, che sia planare e non siano presenti rotture o parti distaccate. Se queste condizioni non sono interamente soddisfatte procedere come segue:

- Sigillare le crepe e le rotture con una resina epossidica bicomponente (come EPORIP di Mapei spa o simili)
- Riempire i vuoti lasciati da eventuali pietre o piastrelle rimosse usando un prodotto livellante (come ADESILEX P4 o NIVORAPID di Mapei spa o simili)
- Correggere ogni imperfezione di planarità con malte livellanti dopo aver pulito la superficie e aver usato, se necessario, un primer (come ECO PRIM T di Mapei o simili).

In generale i pavimenti esistenti in ceramica o pietra naturale devono essere accuratamente puliti con una soluzione di acqua tiepida e soda caustica al 20%, e sciacquati abbondantemente per rimuovere ogni traccia di sostanza. In alcuni casi la superficie può essere sottoposta ad abrasione, per ottenere un supporto più ruvido e aumentare l'aderenza delle colle.

LA POSA

Prima di installare le lastre Gigacer occorre selezionare l'adesivo più adatto a seconda del tipo di supporto, delle condizioni climatiche e del tempo che intercorrerà tra la posa e l'inizio dell'utilizzo della superficie calpestabile. La tabella seguente illustra alcuni esempi di adesivi adatti alla posa delle lastre Gigacer, sia di 12mm che di 4,8mm di spessore.

ADESIVI CONSIGLIATI

Ardex

Mapei

Kerakoll

Per una posa perfetta e una completa bagnatura consigliamo, soprattutto in caso di utilizzo delle lastre sottili in 4,8mm e 6mm, di effettuare la doppia spalmatura, applicando la colla sia sul retro della lastra che sul supporto. Applicare prima uno strato dentile di colla sul retro della lastra con una spatola liscia, e di seguito applicare altro adesivo stendendolo con una spatola dentata effettuando movimenti semicircolari. Applicare poi la colla sul sottofondo con una spatola dentata e posare la lastra. Battere la lastra con un martello di gomma per assicurarsi della perfetta bagnatura e scongiurare la presenza di vuoti d'aria. È possibile utilizzare sistemi per agevolare la perfetta planarità della posa, soprattutto con lastre di grande formato, come ad esempio il Tuscan Leveling System.

STUCCATURA

Consigliamo una fuga di 2mm in caso di posa multiformato e 2-4mm in caso di posa di un formato unico. È necessario consultare le nostre tabelle di caratteristiche tecniche e applicare i giunti di dilatazione necessari. Lo stucco deve essere applicato solo dopo che l'adesivo si sia indurito, normalmente dopo 3 ore in caso di adesivo rapido e dopo 24 ore in caso di adesivo standard. Questi valori si riferiscono ad una posa all'asciutto effettuata a una temperatura di +23°C e con il 50% di umidità relativa.

THE SUBSTRATE

The floor substrate must be resistant enough to bear the expected stress and weight added with the ceramic tiles, it must be perfectly planar, perfectly aged (aged 28 days or according to the manufacturer's specifications) and dry, and free of any loose part such as oil, water, dust, paint, grease etc., which might compromise the adhesion of the slabs.

REINFORCED CONCRETE SUBSTRATE

The substrate must be aged, cured, clean, dry and free of any substance which might compromise the adhesion of the ceramic. Any crack due to hygrometric shrinkage must be sealed using a two-component epoxy fluid adhesive (ie. EPORIP by Mapei or similar). If the concrete support is dirty or has surface dust it must be thoroughly cleaned and the a suitable single-component resin primer with a very low content of colatile organic compounds (VOC) must be applied (ie. PRIMER G or ECO PRIM T by Mapei spa or similar). If the concrete surface has any surface inconsistencies it must be consolidated with a suitable single-component or two-component epoxy or polyurethane primer (such as PRIMER MF or ECOPRIM PU 1K by Mapei spa or similar).

SCREED COATS

The screed surface must be aged (aged 28 days or according to the manufacturer's specifications), cured, clean, dry and free of any substance which might compromise the adhesion of the ceramic. Any crack due to hygrometric shrinkage must be sealed using a two-component epoxy fluid adhesive (ie. EPORIP by Mapei or similar). Once the surface is completely cured it is important to check that it is strong enough to bear the weight of the ceramic that will be fixed on it. If the concrete support is dirty or has surface dust it must be thoroughly cleaned and the a suitable single-component resin primer with a very low content of colatile organic compounds (VOC) must be applied (ie. PRIMER G or ECO PRIM T by Mapei spa or similar). If the concrete surface has any surface inconsistencies it must be consolidated with a suitable single-component or two-component epoxy or polyurethane primer (such as PRIMER MF or ECOPRIM PU 1K by Mapei spa or similar). For floor heating installations the correct switch on cycle of the system must be performed in compliance with the applicable standards and the indications of the manufacturer of the floor heating system.

EXISTING CERAMICS OR STONE FLOORINGS

For ceramic and stone floorings, check that the existing covering is perfectly attached to the support, planar and free of any cracks or sections that tend to detach from the substrate. If not proceed as follows:

- seal the floor cracks with two-component fluid epoxy resins (such as EPORIP by Mapei spa or similar);
- fill any gaps created when removing any tiles or slabs that do not adhere, using rapid setting thixotropic smoothing compounds (such as ADESILEX P4 or NIVORAPID by Mapei spa or similar);
- correct any planarity imperfections with levelling mortars, after cleaning the existing surface and, if necessary, using a suitable primer (such as ECO PRIM T by Mapei spa or similar).

Generally speaking existing ceramic or stone floorings must be suitably cleaned with a solution of warm water and caustic soda at 20%, and rinsed thoroughly to remove any trace of loose substances. In specific cases the surface can be subjected to some surface abrasion to achieve a rough and clean support, in order to improve the subsequent adhesion.

TILES INSTALLATION

Before laying Gigacer slabs select the most suitable adhesive according to the type of support, the final environment, the weather conditions of the site and the time available between laying and use. The table below lists a few examples of adhesive systems suitable for laying our slabs on horizontal indoor surfaces.

SUGGESTED ADHESIVES

Ardex

Mapei

Kerakoll

For a perfect installation and a complete wetting we suggest to apply the adhesive with double spreading, applying the glue both on the substrate and on the back of the tile. We suggest to use this procedure especially for 4,8mm and 6mm slabs.

Apply the adhesive with an adequately sized notched trowel, firstly laying one thin layer on the support with the flat edge of the trowel and then applying the desired thickness with the notched edge. Then apply the adhesive on the substrate with a notched trowel and lay the tile. Beat the tile with a rubber hammer to ensure perfect wetting and remove any air bubble which might have generated between the tile and the substrate. It is possible to use systems such as Tuscan Leveling or similar to help maintaining the perfect planarity of the floor.

GROUTING

We suggest to use 2mm joints in case of multi-format flooring and 2-4 mm in case of single-format. Please read carefully our technical specifications charts and apply the necessary dilatation joints. The joints must be grouted only after the adhesive has hardened, normally 3 hours for fast set adhesives and at least 24 hours for regular set adhesives. These values refer to laying carried out at +23°C and 50 % relative humidity.

PULIZIA E MANUTENZIONE | CLEANING AND MAINTENANCE

SURFACES CLEANING	ARGILLA QUARTZ CONCEPT 1 LEVIGATO INCLUSIONI CLASSICO LEVIGATO INCLUSIONI EXTRAFINE LEVIGATO INCLUSIONI SOAVE SOFT MADE 2.0 LEVIGATO	ARGILLA MATERIAL CONCEPT 1 MAT / BOCCIARDATO / TEXTURE CONCRETE DÉCO ELEMENTA MAT / BOCCIARDATO GATSBY INCLUSIONI CLASSICO MAT INCLUSIONI EXTRAFINE MAT INCLUSIONI SOAVE MAT / BOCCIARDATO KREA LIGHT LIGHT 250 MADE 2.0 MAT / BOCCIARDATO QUARRY MAT / BOCCIARDATO LE CORBUSIER LCS CERAMICS POINTILLÉ
Pulizia dopo posa Initial cleaning	Deterdek Pro ÈCOSÌ Cherodal	Deterdek Pro È COSÌ Cherodal
Protezione superficiale Surface protection	Fila MP90	/
Pulizia ordinaria Daily maintenance	Cleaner Pro ÈCOSÌ Velvet	Cleaner Pro ÈCOSÌ Velvet
Pulizia straordinaria Extraordinary cleaning	PS87 Pro / SR95 ÈCOSÌ Mic One	PS87 Pro / SR95 ÈCOSÌ Mic One
TIPO DI SPORCO	DETERGENTE	
Grassi animali e vegetali, gelato, succhi di frutta, the, macchie di verdura Animal and vegetable grease, ice cream, fruit juices, tea, vegetable stains	Detergente a base alcalina: PS87 Pro	
Vino, birra, aceto, caffè, inchiostri, pennarelli, nicotina, urina, vomito, coca cola, tintura per capelli Wine, beer, vinegar, coffee, inks, markers, nicotine, urine, vomit, coca cola, hair dye	Detergente a base alcalina: PS87 Pro o smacchiante SR95 o ÈCOSÌ Mic One	
Depositi efflorescenze calcare, ruggine, malte, segni metallici, cera protettiva antiabrasione Limescale, rust, mortar, metallic marks, anti-abrasion protective wax deposits	Detergente a base acida: Deterdek Pro o ÈCOSÌ Cherodal	
Resine, bitume, cere di candele, catrame, residui di scotch Resins, bitumen, candle waxes, tar, scotch residues	Solvente SOLV	
Vernice, graffiti Paint, graffiti	Detergente a base alcalina: PS87 Pro o sverniciante FILA NO PAINT STAR	

PULIZIA STRAORDINARIA | INTENSIVE MAINTENANCE

TIPO DI MACCHIA TYPE OF SPOTS	ECOSI	FILA	SOLVENTI SOLVENTS	ACIDI ACIDS	ALCALI ALKALI
Birra Beer	Mic One	PS87 Pro			•
Caffè Coffee	Mic One	PS87 Pro			•
Calcare Limescale marks	Cherodal	Deterdek Pro		•	
Catrame Tar	Mic One	PS87 Pro	•		
Cemento Cement	Cherodal	Deterdek Pro		•	
Cera di candela Candle wax	Acqua calda + terra Hot water	Acqua calda Hot water	•		•
Coca Cola Cola	Mic One	PS87 Pro		•	•
Colla Glue	Cherodal	Deterdek Pro	•		
Gelato Ice-cream	Mic One	PS87 Pro			•
Gomma da masticare Chewing gum	Ghiaccio secco Dry ice	Ghiaccio secco Dry ice	•		•
Gomma di pneumatico Tyre rubber	Mic One	PS87 Pro	•		•
Inchiostro Ink	Mic One	PS87 Pro	•		•
Nicotina Nicotine	Mic One	PS87 Pro			•
Pennarello Marker	Mic One	PS87 Pro	•		•
Resine Resin	Mic One	PS87 Pro	•		
Ruggine Rust	Cherodal	Deterdek Pro		•	
Smalto per unghie Nail-polish	Mic One	PS87 Pro	•		
Sangue Blood	Mic One	PS87 Pro			•
Sigaretta Cigarette	Mic One	PS87 Pro		•	
Verince murale Wall painting	Cherodal	Deterdek Pro		•	
Vino Wine	Mic One	PS87 Pro			•
Olio Oil	Mic One	PS87 Pro			•
Grasso Grease	Mic One	PS87 Pro			•

CONSIGLI PER LA PULIZIA | CLEANING TIPS

I prodotti GIGACER vengono sottoposti continuamente a tutti i test di resistenza alle macchie previsti dalle norme UNI EN. La superficie di una piastrella completamente greificata è composta da materiale simile al vetro e come tale va trattata in fase di pulizia.



PULIZIA INIZIALE

La prima pulizia dopo la posa è la più importante nella intera vita del pavimento. Serve a rimuovere qualsiasi residuo di stucco, colla, cemento, calce o boiacca, che se lasciati sulla superficie delle lastre possono minare definitivamente le caratteristiche di pulibilità del pavimento in ceramica. Non utilizzare mai strumenti meccanici per la prima pulizia: la rimozione dei residui di stucco e colla è un procedimento chimico.

STUCCO UTILIZZATO	QUANDO FARE LA PULIZIA	COSA USARE	MODALITA' D'USO
Stucco cementizio miscelato con acqua	Dopo 2/3 giorni ed entro 7 giorni dalla stuccatura	Detergente a base acida - Deterdek Pro o ECOSì Cherodal	Seguire le istruzioni fornite dal produttore del detergente. Testare preventivamente il detergente su una piastrella non posata o in posizione nascosta prima dell'uso, in particolare su prodotti lappati, lucidati o levigati. Le superfici da pulire devono essere inumidite con acqua prima del lavaggio. Lasciare agire il prodotto per alcuni minuti, sempre seguendo le istruzioni del produttore. A fine lavaggio raccogliere il liquido dal pavimento e sciacquare abbondantemente con acqua. Raccogliere l'acqua di risciacquo con aspiraliquidi o strofinaccio. Ripetere l'operazione di risciacquo fino a che tutti i residui acidi non sono stati rimossi.
Stucco epossidico, bi-componente e reattivo	Immediatamente	Seguire le indicazioni del produttore dello stucco	La pulizia deve essere eseguita subito ed accuratamente, dal momento che questo tipo di stucchi indurisce molto rapidamente, anche nel giro di pochi minuti. Seguire tassativamente le modalità di pulizia indicate dal fabbricante dello stucco e verificarne l'efficacia con una prova preliminare di pulizia prima di procedere alla stuccatura dell'intera superficie piastrellata. Verificare bene che tutto lo stucco venga debitamente rimosso anche osservando la superficie controluce.

La pulizia delle superfici bocciardate è più laboriosa. Consigliamo di procedere rapidamente e di utilizzare spazzole che possano raggiungere anche le aree più difficili.

Se la pulizia iniziale non è stata fatta correttamente è possibile che si notino sul pavimento residui, patine lucide o aloni localizzati in particolare attorno alle fughe. In questi casi è necessario ripetere l'operazione di pulizia iniziale dopo posa, eventualmente utilizzando i detergenti in concentrazioni maggiori e lasciandoli agire più a lungo. Gli stucchi, una volta asciugati, sono di difficilissima rimozione, a volte impossibile. Contattare il produttore dello stucco.

PULIZIA QUOTIDIANA

Per la pulizia quotidiana è sufficiente asportare la polvere con un panno in microfibra, lavare la superficie con il detergente neutro a basso residuo VELVET ECOSì o Cleaner Pro diluiti in acqua come indicato dal produttore (circa una tazzina in un secchio da 5 litri d'acqua) utilizzando uno straccio umido che andrà sciacquato spesso nella soluzione. È essenziale utilizzare un detergente neutro privo di cere, acidi, solventi o componenti abrasive. L'uso di acqua sporca o prodotti lucidanti o un eccesso di detergenti può, col tempo, formare una patina invisibile sulla superficie delle lastre, causa di aloni e macchie. Non utilizzare mai smacchiatori tipo antiruggine o di tipo spray perché spesso contengono acido fluoridrico, che danneggerebbe irreparabilmente il pavimento. È bene impermeabilizzare le fughe con il protettivo per fughe tipo FUGAPROOF della FILA, il quale impedisce l'assorbimento di macchie, facilita la rimozione dello sporco e mantiene la fuga come nuova per lungo tempo.

Se la pulizia quotidiana non viene effettuata correttamente è possibile che appaiano aloni opachi, che il pavimento risulti più lucido di quanto non dovrebbe o che rimangano impronte al passaggio. In questi casi è bene applicare un detergente tipo Cleaner Pro non diluito e lasciare agire per 5-10 minuti. Quindi frizionare con un tampone o uno straccio. Risciacquare abbondantemente e raccogliere i liquidi con uno straccio o una macchina aspiraliquidi. Asciugare infine con un panno in microfibra.

Gigacer non sarà mai responsabile per alterazioni superficiali che possano avvenire sul pavimento se questo viene pulito con procedimenti meccanici e non con i prodotti e i procedimenti indicati in questa guida.

GIGACER products are constantly controlled and undergo all kind of stain resistance tests recommended by UNI EN. The surface of a perfectly vitrified tile is made by a material similar to glass and it must be treated like glass when it must be cleaned.



INITIAL CLEANING

The first cleaning after installation is the most important in the whole life of the floor. It is made to remove any residue of grout, glue or cement, that if are left on the surface of the slabs might compromise the stain resistance properties of the ceramic floor. Never use mechanic machines for initial cleaning: grout and glue residues removal is a chemical process.

TYPE OF GROUT	WHEN IT MUST BE CLEANED	WHAT TO USE	HOW TO CLEAN IT
Cementitious grout mixed with water	After 2/3 days and within 7 days from grouting	Acide detergent - Deterdek Pro or ECOSì Cherodal	Follow the instructions provided by the producer of the cleaning solution. Previously test the detergent on a tile that hasn't been installed or on a hidden part of the floor before using the detergent on the whole surface, in particular on honed or polished floors. The surface must be moistened with water before washing. Leave the solution on the floor for some minutes, always following the instructions of the cleaning solution producer. Then collect the liquids and rinse thoroughly with water. Absorb the water with a rug or a vacuum machine until all the residues have been removed. Repeat rinsing operations if needed, until all residues will have been removed.
Epoxy or bi-component grouts	Immediately	Follow the instructions of the grout producer	Cleaning must be done immediately and very carefully, because this kind of grouts harden very quickly. Strictly follow the instructions provided by the grout producer and previously verify their effectiveness on a loose tile before proceeding with grouting operations on the whole area. Check carefully that all grout residues have been removed by observing the surface backlight.

Cleaning bush-hammered surfaces is more demanding. We suggest to proceed immediately and to use brushes that can reach even the most difficult area.

If the initial cleaning has not been carried out correctly it is possible to see residues or stains on the floor, especially along the joint spacings. In these cases it is necessary to repeat the initial cleaning operation, using the cleaning solutions in higher concentrations and leaving them longer on the floor. It is very difficult to remove grout once it's dry. Please contact the grout producer in case of problems.

DAILY MAINTENANCE

For daily maintenance we suggest to remove dust with a microfiber cloth, then wash the surface with a neutral detergent with low residue, like VELVET ECOSì or Cleaner Pro diluted in water as indicated by the producer (about 3 spoons in a 5 litres of water) using a wet cloth. The cloth must be washed very often in the water and detergent solution. It is crucial that the solution used is neutral, without wax, acids, solvents or abrasive particles. Using dirt water, polishing products or too much detergent can form an invisible layer on the surface of the slabs, causing stains and allowing the floor to retain dust. Never use stain removers, anti rust or spray because they often contain hydrofluoric acid that would damage the floor irreparably.

We suggest to waterproof the grouted joints with FILA's FUGAPROOF, that prevents water absorption by the joints, makes it easier to remove dirt and keeps joints clean for a long time.

If daily maintenance is not carried out correctly it is possible to see opaque halos on the surface of the tiles, that the floor looks more glossy than it should or that footprints remain after walking. In these cases we suggest to apply a neat detergent such as Cleaner Pro and leave it for 5-10 minutes. Then rub with a cloth or a rug. Rinse thoroughly with water and collect the liquids with a rug or with a vacuum machine. Dry with a microfiber cloth.

Gigacer will never be held responsible for changes that might occur to the surface of the floor if it is cleaned with mechanical procedures and not with the products and procedures indicated in this guide.

INDICE DI STONALIZZAZIONE | SHADE VARIATION INDEX

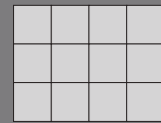

V1 - LOW
Prodotto monocromatico.
 Monochromatic product.

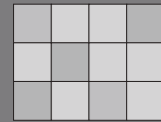

V2 - MODERATE
Prodotto con leggera variazione cromatica.
 Product with light chromatic variation.



V3 - HIGH
Prodotto con marcata variazione cromatica.
 Product with high chromatic variation.

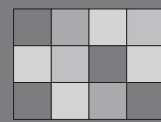

V4 - VERY HIGH
Prodotto con forte variazione cromatica.
 Product with very high chromatic variation.

Collezione Collection	Indice Index
Argilla	V2
Argilla Pentagon PlayOne	V3
Concept 1 Mat Levigato Texture Bocciardato	V2
Concept 1 Texture Platinum Red Flame Turquoise	V3
Concept 1 PlayOne	V3
Concrete	V1
Concrete PlayOne	V2
Concrete / Made 2.0 Blend	V4
Déco	V4
Elementa All sizes	V3
Gatsby	V2
Inclusioni Classico / Extrafine / Soave	V3
Krea	V3
Krea PlayOne	V4
Light	V2
Light 250	V2
Made 2.0	V1
Quarry	V3
LCS1	V1
Béton gris 120x250 120x120	V2
Béton gris 60x120 30x120 60x60	V3
Béton blanc All sizes	V1
Molitor 120x250 120x120	V2
Molitor 60x120 60x60	V3
Tokyo All sizes	V1
Pontillé 120x250	V2
Pontillé other sizes	V4
Tele	V3

CALIBRI | CALIBERS

Le nostre lastre sono sempre rettificate e hanno dimensioni finali in millimetri come da tabella.
 Il calibro standard è lo 09 e i formati dello stesso calibro multipli tra loro sono modulari con 2mm di fuga.

Our slabs are always rectified and the table below indicates their final size in millimetres.
 Our standard caliber is 09 and all sizes with the same caliber, when multiples, are modular with 2mm joint spacing.

Formato nominale (cm) Nominal size (cm)	Formato rettificato (mm) Rectified size (mm)	Calibro Caliber
120x250	1190x2500	09
60x250	594x2500	09
120x120	1190x1190	09
60x120	594x1190	09
30x120	296x1190	09
25x120	250x1190	09
60x60	594x594	09
30x60	296x594	09
30x30	296x296	09
15x60	147x594	09
10x60	97x594	09
5x60	47x594	09
20x20	197x197	09
15x15 Gigacer Shades	146x146	00

MODULARITÀ | MODULARITY



IMBALLI | PACKAGING

Spessore Thickness	Formato Size (cm)	Pallet (cm)	Pezzi x collo PCS/BX	M ² x collo SQM/BX	Kg x collo KG/BX	Colli x pallet BX/PLT	M ² x pallet SQM/PLT	Kg x pallet KG/PLT
24 mm	120x120	120x120	1	1,44	82,00	12	17,28	1010
	60x120	120x120	1	0,72	41,00	24	17,28	1010
	60x60	120x120	1	0,36	20,50	48	17,28	1010
20 mm	60x120	94x122	1	0,72	32,50	36	25,92	1190
12 mm through body	120x250 Unrectified	272x133x42h	1	3,00	84,00	12	36,00	1108
	120x250 Rectified	272x133x42h	1	3,00	84,00	12	36,00	1108
12 mm	120x120	120x120	1	1,44	40,30	36	51,84	1482
	60x120	120x120	2	1,44	40,30	36	51,84	1482
	60x60	120x120	3	1,08	30,20	48	51,84	1482
	30x60	120x120	4	0,72	20,20	72	51,84	1482
	15x60	80x120 euro	8	0,72	20,20	56	40,32	1161
	15x15	120x120	32	0,72	20,20	64	46,08	1322
	Large Pentagon	-	1	1,00	28,00	36	36,00	1048
	120x120 Quarry	120x120	1	1,44	40,30	36	51,84	1482
	60x120 Quarry	120x120	2	1,44	40,30	36	51,84	1482
	60x60 Quarry	120x120	2	0,72	20,10	72	51,84	1482
	30x60 Quarry	120x120	2	0,36	10,00	144	51,84	1482
	30x30 Quarry	120x120	2	0,18	5,00	288	51,84	1482
	Blend 5-10-15x60	-	12	0,72	20,20	48	34,56	999
	Brick Bar	80x120	12	0,54	14,00	40	2,16	599
	Mix Mosaic 3x3	80x120 euro	8	-	20,20	-	-	-
	Trail Mosaic 2x10	80x120 euro	8	-	20,20	-	-	-
	Battiscopa . Skirting 60x71	-	10	-	16,00	-	-	-
	Gradino costa retta Costa retta step 60x33x4	-	4	-	26,00	-	-	-
	Gradino costa retta Costa retta step 120x33x4	-	2	-	26,00	-	-	-
	6 mm	120x250	272x133x42h	1	3,00	42,60	22	66,00
60x250		272x133x42h	1	1,50	21,00	44	66,00	1024
120x120		124x137	2	2,88	41,00	20	57,60	860
60x120		124x137	4	2,88	40,80	24	69,12	1021
60x60		124x137	4	1,44	20,50	40	57,60	860
63,5x11,5 Chevron		80x120 euro	10	0,73	8,00	40	29,20	340
30x120		124x137	4	1,44	20,50	48	69,12	1021
30x120 LCS1		80x120 euro	2	0,72	10,20	60	43,20	645
25x120 LCS3	80x120 euro	2	0,60	9,00	60	36,00	570	

Spessore Thickness	Formato Size (cm)	Pallet (cm)	Pezzi x collo PCS/BX	M ² x collo SQM/BX	Kg x collo KG/BX	Colli x pallet BX/PLT	M ² x pallet SQM/PLT	Kg x pallet KG/PLT
6 mm	30x60	124x137	8	1,44	20,50	48	69,12	1014
	15x60	80x120 euro	16	1,44	20,50	48	69,12	1021
	Large Pentagon	-	1	1,00	14,00	40	40,00	588
	Mosaic Chevron	-	7	-	8,00	-	-	-
	Mosaic 30x30 (1,5x1,5)	-	10	-	10,00	-	-	-
	Wall Mosaic 30x30	-	10	-	13,00	-	-	-
	Stripes Mosaic 30x60	-	6	-	14,00	-	-	-
	Stripes Mosaic 15x120	-	4	-	9,00	-	-	-
	Action Mosaic 30x30 (4,4x5,2)	-	10	-	13,00	-	-	-
	Mosaic 30x30 (0,7x0,7)	-	10	-	8,50	-	-	-
	Button	-	22	0,02	0,25	-	-	-
	Small	-	44	0,36	4,60	-	-	-
	Brick	-	22	0,36	4,60	-	-	-
	Plate	-	22	0,60	7,70	-	-	-
	Triangle	-	18	0,24	3,25	-	-	-
	Diamond	-	9	0,24	3,25	-	-	-
	Octagon (Button included)	-	20	1,80	25,00	-	-	-
	Small Pentagon	-	24	0,96	13,50	-	-	-
	Small Hexagon	-	11	0,23	3,00	-	-	-
	Large Hexagon	-	14	1,18	15,00	-	-	-
Battiscopa . Skirting 120x71	-	8	-	8,00	-	-	-	
Gradino costa retta Costa retta step 60x33x4	-	4	-	26,00	-	-	-	
Gradino costa retta Costa retta step 120x33x4	-	2	-	26,00	-	-	-	
6/12 mm	Blend 5-10-15x60	-	18	1,08	12,00	48	51,84	588

IMBALLI | PACKAGING

Spessore Thickness	Formato Size (cm)	Pallet (cm)	Pezzi x collo PCS/BX	M ² x collo SQM/BX	Kg x collo KG/BX	Colli x pallet BX/PLT	M ² x pallet SQM/PLT	Kg x pallet KG/PLT
4.8 mm	120x120	124x137	2	2,88	34,60	23	66,24	835
	60x120	124x137	4	2,88	34,60	24	69,12	870
	60x60	124x137	5	1,80	21,60	40	72,00	904
	30x60	124x137	10	1,80	21,60	48	86,40	1067
	15x15	80x120 euro	22	0,50	5,90	112	55,44	690
	Blend 5-10-15x60	-	24	1,44	17,30	48	69,12	860
	Mosaic 30x30 (1,5x1,5)	-	10	-	10,00	-	-	-
	Wall Mosaic 30x30	-	10	-	9,00	-	-	-
	Stripes Mosaic 30x60	-	6	-	11,00	-	-	-
	Stripes Mosaic 15x120	-	4	-	7,00	-	-	-
	Action Mosaic 30x30 (4,4x5,2)	-	10	-	9,00	-	-	-
	Mosaic 30x30 (0,7x0,7)	-	10	-	7,00	-	-	-
	Button	-	22	0,02	0,25	-	-	-
	Small	-	44	0,36	4,60	-	-	-
	Brick	-	22	0,36	4,60	-	-	-
	Plate	-	22	0,60	7,70	-	-	-
	Triangle	-	18	0,24	3,25	-	-	-
	Diamond	-	9	0,24	3,25	-	-	-
	Octagon (Button included)	-	22	1,98	23,70	-	-	-
	Small Pentagon	-	24	0,96	13,50	-	-	-
Small Hexagon	-	11	0,23	3,00	-	-	-	
Large Hexagon	-	14	1,18	15,00	-	-	-	
Battiscopa . Skirting 120x71	-	8	-	11,00	-	-	-	



CARATTERISTICHE TECNICHE | TECHNICAL SPECIFICATIONS

LASTRE DI GRES PORCELLANATO PORCELAIN SLABS - ISO 13006 - G - Bia UGL (E ≤ 0,5%) UNI EN 14411 - G -					
	CARATTERISTICHE TECNICHE TECHNICAL SPECIFICATIONS	NORMA ISO STANDARD	SPESSORE THICKNESS	VALORI PRESCRITTI DALLE NORME INTERNATIONAL STANDARDS	VALORE MEDIO GIGACER AVERAGE GIGACER VALUE
	CARATTERISTICHE DIMENSIONALI DIMENSIONAL CHARACTERISTICS	ISO 10545-2	-	S > 410	
	LATI SIDES		-	± 0,6%	± 0,2%
	SPESSORE THICKNESS		-	± 5%	± 3%
	RETTILINEITÀ DEGLI SPIGOLI STRAIGHTNESS OF EDGES		-	± 0,5%	± 0,2%
	ORTOGONALITÀ RECTANGULARITY		-	± 0,6%	± 0,2%
	PLANARITÀ SURFACE FLATNESS	-	-	± 0,5%	± 0,2%
	ASSORBIMENTO D'ACQUA WATER ABSORPTION	ISO 10545-3	-	++ ≤ 0,5%	≤ 0,1%
	RESISTENZA ALLA FLESSIONE BENDING STRENGTH	ISO 10545-4	≠ 4.8/6 mm	≥ 35 N/mm ²	≥ 40 N/mm ²
			≠ 12 mm	≥ 35 N/mm ²	≥ 40 N/mm ²
			≠ 20 mm	≥ 35 N/mm ²	≥ 50 N/mm ²
			≠ 24 mm	≥ 35 N/mm ²	≥ 52 N/mm ² **
	SFORZO DI ROTTURA BREAKING STRENGTH	ISO 10545-4	≠ 4.8/6 mm	S ≥ 700N (sp. < 7,5mm)	> 700 N
			≠ 12 mm	S ≥ 1.300N (sp. ≥ 7,5mm)	≥ 4000 N
			≠ 20 mm	S ≥ 1.300N (sp. ≥ 7,5mm)	≥ 13600 N
			≠ 24 mm	S ≥ 1.300N (sp. ≥ 7,5mm)	≥ 20000 N**
	RESISTENZA ALL'ABRASIONE PROFONDA RESISTANCE TO DEEP ABRASION	ISO 10545-6	-	≤ 175mm ³	≤ 145 mm ³
	COEFFICIENTE DI DILATAZIONE TERMICA LINEARE COEFFICIENT OF LINEAR THERMAL EXPANSION	ISO 10545-8	-	REQUISITO NON RICHIESTO CONDITION NOT REQUIRED	≤ 7x10 ⁻⁶ °C ⁻¹
	RESISTENZA AGLI SBALZI TERMICI RESISTANCE TO THERMAL SHOCKS	-	-	METODO DISPONIBILE AVAILABLE METHOD	RESISTE RESISTANT
	RESISTENZA AL GELO FROST RESISTANCE	ISO 10545-12	-	METODO DISPONIBILE AVAILABLE METHOD	RESISTE RESISTANT
	RESISTENZA ALL'ATTACCO CHIMICO RESISTANCE TO CHEMICAL ATTACKS	ISO 10545-13	-	min. UB	RESISTE RESISTANT
	RESISTENZA ALLE MACCHIE STAIN RESISTANCE	ISO 10545-14	-	METODO DISPONIBILE AVAILABLE METHOD	RESISTE RESISTANT
	RESISTENZA AI PRODOTTI DI PULIZIA ANTICOVID ANTICOVID CLEANING PRODUCTS RESISTANCE	-	-	-	RESISTE RESISTANT

Trattandosi di un prodotto tecnico a solo impasto senza smalto alcune impurità e puntinature visibili nei colori chiari sono da considerarsi una caratteristica tecnica del prodotto. We produce technical unglazed porcelain stoneware slabs, and some light impurities and dots must be considered as a standard feature of the product.

I valori di resistenza allo scivolamento, coefficiente di attrito statico e dinamico, riportati sul catalogo e sul sito, sono da ritenersi puramente indicativi e non vincolanti. Ogni eventuale specifica necessità dovrà essere da noi confermata al momento dell'ordine e comunque sempre prima della posa. The values of slip resistance and of static and dynamic friction coefficient shown in the catalogue, and in the web site are merely indicative and non-binding. Any possible specific requirement must be confirmed by us at the order and anyway always before the installation.

COEFFICIENTE DI ATTRITO | COEFFICIENT OF FRICTION

LASTRE DI GRES PORCELLANATO PORCELAIN SLABS - ISO 13006 - G - BIA UGL (E ≤ 0,5%) UNI EN 14411 - G -											
	SUPERFICI SURFACES	SPESSORE THICKNESS	DIN 51130	DIN 51097	BCR	BRITISH PENDULUM BS7976	R9729 UPI/ EMPA	DCOF (SECTION 9.6 ANSI A 137.1.2012)			
 COEFFICIENTE D'ATTRITO COEFFICIENT OF FRICTION	BETON	≠6mm ≠12mm	-	-	> 0,40	-	GS1	> 0,42 wet			
	MOLITOR	≠6mm	R10*	-	> 0,40	-	GS1	> 0,42 wet			
		≠12mm ≠24mm	R10	A + B	> 0,40	> 36 WET	GS2/GB1	> 0,42 wet			
	TOKYO	≠6mm	R10	A	> 0,40	-	GS1	> 0,42 wet			
	ARGILLA MATERIAL	≠6mm	R10	A + B	> 0,40	-	-	-			
	CONCEPT 1	MAT	≠6mm ≠12mm ≠24mm	R10	-	-	> 36 WET	GS1	-		
		TEXTURE MAT	≠6mm	R10	A	-	-	-	-		
		BOCCIARDATO	≠12mm ≠24mm	R10	A + B	> 0,40	> 36 WET	GS2/GB1	> 0,42 wet		
		BOCCIARDATO ANTISLIP	≠12mm ≠24mm	R11	A + B + C	> 0,40	> 36 WET	GS2/GB1	> 0,42 wet		
	CONCRETE		≠4.8mm ≠6mm	R10	A + B*	> 0,40	-	GS1	-		
			≠12mm ≠24mm	R10	A + B	> 0,40	> 36 WET except for ice colour	GS2/GB1	> 0,42 wet		
	ELEMENTA	MAT	≠6mm	R10	A + B*	> 0,40	-	GS2/GB1	-		
		BOCCIARDATO ANTISLIP	≠20mm	R11	A + B + C	> 0,40	> 36 WET	GS2/GB1	> 0,42 wet		
	INCLUSIONI	CLASSICO	MAT	≠12mm	R10	A + B*	> 0,40	> 36 WET	GS2/GB1	> 0,42 wet	
			MAT	≠6mm	R10	A	> 0,40	-	GS1	> 0,42 wet	
		SOAVE	MAT	≠12mm ≠24mm	R10	A + B*	> 0,40	> 36 WET	GS2/GB1	> 0,42 wet	
			BOCCIARDATO BOCCIARDATO ANTISLIP		R10 R11	A + B A + B + C	> 0,40 > 0,40	> 36 WET > 36 WET	GS2/GB1 GS2/GB1	> 0,42 wet > 0,42 wet	
	KREA		≠4.8mm ≠6mm	R10	A + B*	> 0,40	-	GS1	-		
			≠12mm ≠24mm	R10	A + B	> 0,40	> 36 WET	GS2/GB1	> 0,42 wet		
	LIGHT		≠6mm	CRESPO	R10	A + B	> 0,40	-	GS1	-	
				RIGATO	R9	A	> 0,40	-	GS1	-	
				ROCCIA	R9	A	> 0,40	-	GS1	-	
				SCOLPITO	R10	A + B	> 0,40	-	GS1	-	
				GESSO	R9	A	> 0,40	-	GS1	-	
GESSO				≠12mm	R9	A	> 0,40	-	GS1	-	
MADE 2.0	MAT	≠12mm ≠24mm	R10	-	> 0,40	> 36 WET except for ice colour	GS2/GB1	> 0,42 wet			
	BOCCIARDATO ANTISLIP	≠12mm ≠24mm	R11	A + B + C	> 0,40	> 36 WET	GS3/GB2	> 0,42 wet			
QUARRY	MAT	≠6mm ≠12mm ≠24mm	R10	A+B	> 0,40	> 36 WET	GS2/GB1	> 0,42 wet			
	BOCCIARDATO ANTISLIP	≠12mm ≠24mm	R11	A+B+C	> 0,40	> 36 WET	GS2/GB1	> 0,42 wet			

* Valore medio. Average value. | **Dato ottenuto su formato 30x30cm. Measurements made on the 30x30 cm format.

CERTIFICAZIONI | CERTIFICATIONS

GIGACER ha conseguito le certificazioni di processo ISO 9001:2015 e ISO 14001:2015.

Gigacer ha conseguito le certificazioni UNI EN 14411:2012.

La qualità dei prodotti Gigacer viene controllata costantemente tramite test effettuati dai principali laboratori ed enti di certificazione internazionali.

E' possibile scaricare la lista completa dei prodotti Gigacer che hanno ottenuto la certificazione QB-UPEC, completa di valori, al seguente url: www.cstb.fr

Gigacer has achieved the process certifications ISO 9001:2015 e ISO 14001:2015.

Gigacer has achieved the process certifications UNI EN 14411:2012.

The quality of Gigacer products is constantly monitored with tests made by the main international certification laboratories.

It is possible to download the list of Gigacer products that obtained QB-UPEC certification with all the values at the following url: www.cstb.fr

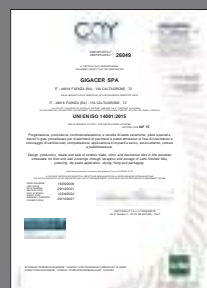

Non si danneggia con i detergenti chimici anticovid.

Does not damage with chemical detergents anticovid.

Photo credits: ©FLC, FLC/ADAGP, FLC/Prolitteris 2014 - Reproductions of the works and portraits of Le Corbusier: © FLC/ADAGP

Quanto contenuto nel catalogo è puramente indicativo riguardo a colori e decorazioni.

Real colors and decorations might slightly differ from those depicted in this catalogue.

Pubblicato da

Published by

Gigacer S.p.A.

Via Caltagirone, 72

48018 Faenza (RA) ITALY

T: +390546637111

F: +390546637127

www.gigacer.it

info@gigacer.it





GIGACER S.P.A.

Via Caltagirone, n.72 - 48018 Faenza (RA) ITALY
Tel. +39 0546 637 111 - Fax +39 0546 637 127
info@gigacer.it - www.gigacer.it

