

# Colonne Piscina Pool Shower Columns

Indoor and Outdoor



**BOSSINI**  
SHOWER SYSTEMS

### L00866 - AQUABAMBÙ

2 rubinetti progressivi - 2 progressive mixers - 2 progressive Mischer  
 2 mitigeurs progressifs - 2 grifos mezcladores progresivos  
 2 прогрессивных смесителя

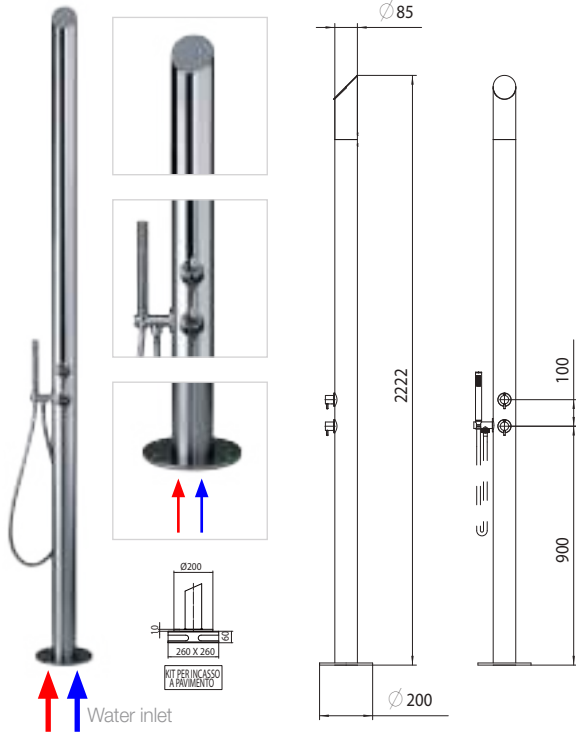

Packaging Box: 1 pz/pcs  
**30x239x30**

Codice/Code	Misura/Size	Finitura/Finish	Portata acqua/ Water flow
<b>L00866</b>	2110 mm	030 cromo/chrome	min 10 L/min

### L00860 - AQUABAMBÙ

2 rubinetti progressivi - 2 progressive mixers - 2 progressive Mischer  
 2 mitigeurs progressifs - 2 grifos mezcladores progresivos  
 2 прогрессивных смесителя

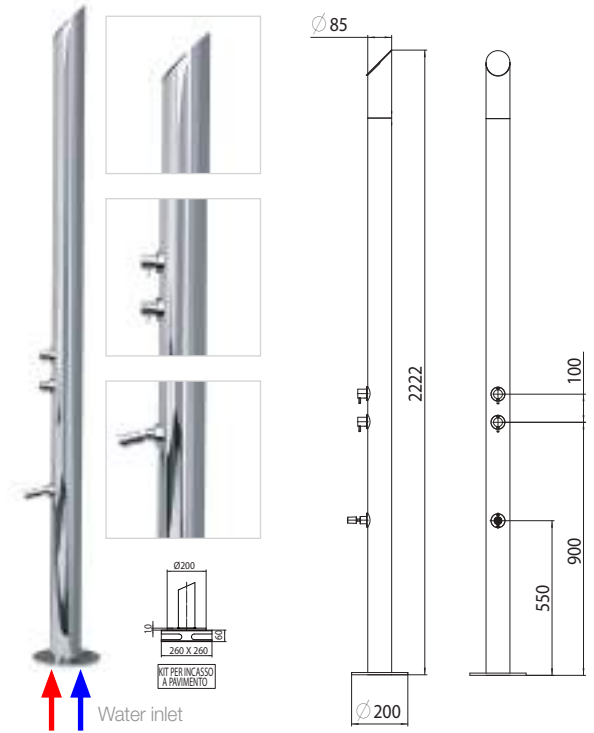

Packaging Box: 1 pz/pcs  
**30x239x30**

Codice/Code	Misura/Size	Finitura/Finish	Portata acqua/ Water flow
<b>L00860</b>	2110 mm	030 cromo/chrome	min 10 L/min

### L00865 - ARCH

2 rubinetti progressivi - 2 progressive mixers - 2 progressive Mischer  
 2 mitigeurs progressifs - 2 grifos mezcladores progresivos  
 2 прогрессивных смесителя

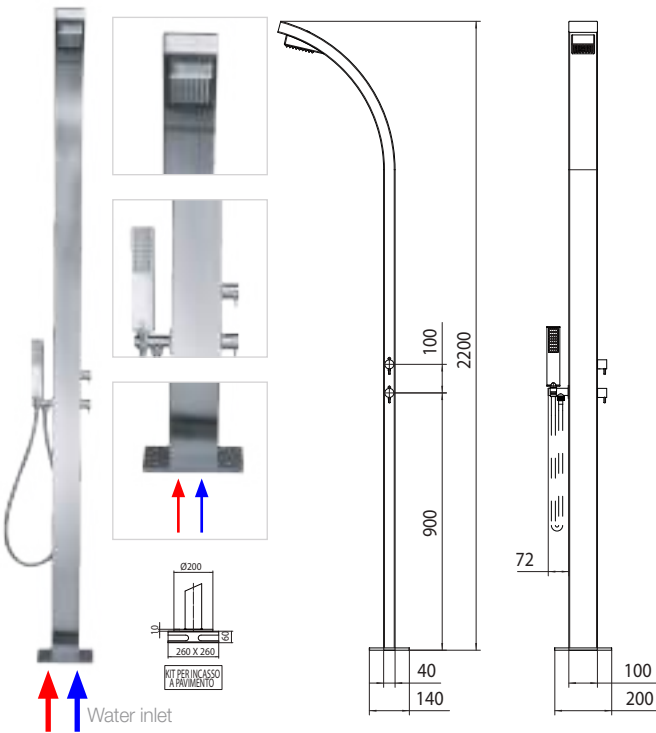

Packaging Box: 1 pz/pcs  
**28x227x42**

Codice/Code	Misura/Size	Finitura/Finish	Portata acqua/ Water flow
<b>L00865</b>	2160 mm	030 cromo/chrome	min 10 L/min

### L00861 - ARCH

2 rubinetti progressivi - 2 progressive mixers - 2 progressive Mischer  
 2 mitigeurs progressifs - 2 grifos mezcladores progresivos  
 2 прогрессивных смесителя

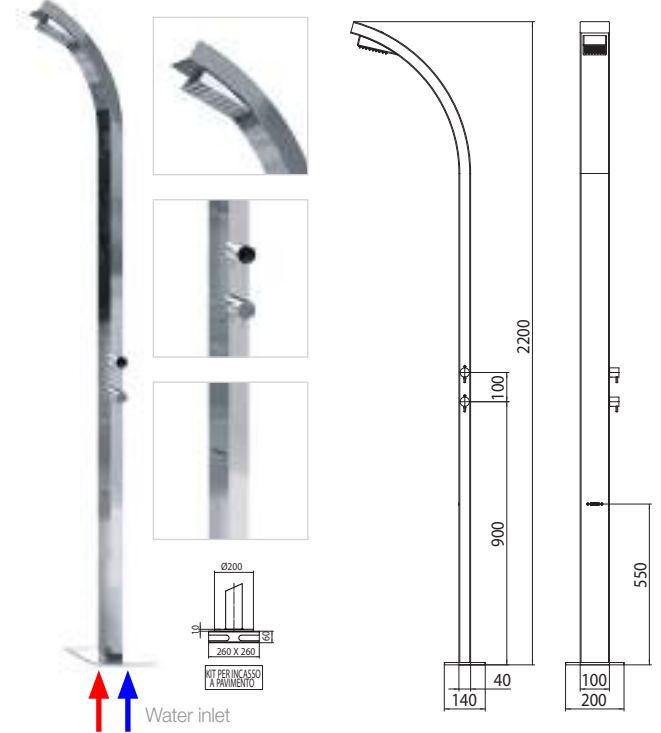

Packaging Box: 1 pz/pcs  
**28x227x42**

Codice/Code	Misura/Size	Finitura/Finish	Portata acqua/ Water flow
<b>L00861</b>	2160 mm	030 cromo/chrome	min 10 L/min

### LO... - NEK

2 rubinetti progressivi - 2 progressive mixers - 2 progressive Mischer  
 2 mitigeurs progressifs - 2 grifos mezcladores progresivos  
 2 Прогрессивных смесителя

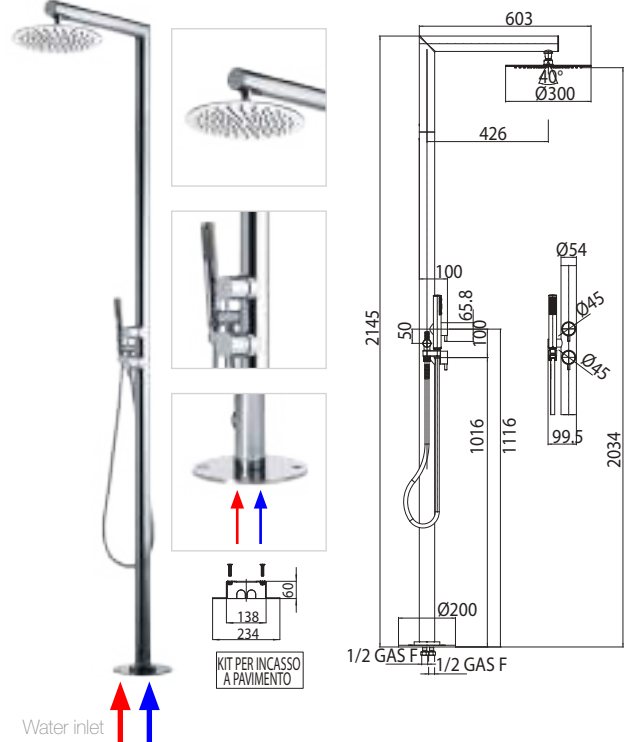

Water inlet

Packaging Box: 1 pz/pc  
 12x51,5x190

Codice/Code	Misura/Size	Finitura/Finish	Portata acqua Water flow
L00379	Ø 300 - 2145 mm	030 cromo/chrome	min 10 L/min
L00380	Ø 250 - 2145 mm	030 cromo/chrome	min 10 L/min

### LO... - NEK

2 rubinetti progressivi - 2 progressive mixers - 2 progressive Mischer  
 2 mitigeurs progressifs - 2 grifos mezcladores progresivos  
 2 Прогрессивных смесителя

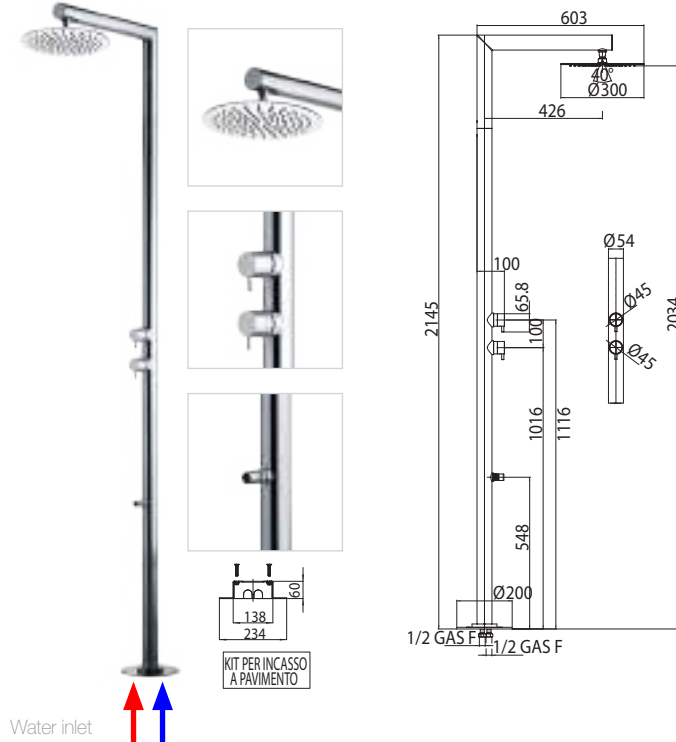

Water inlet

Packaging Box: 1 pz/pc  
 12x51,5x190

Codice/Code	Misura/Size	Finitura/Finish	Portata acqua Water flow
L00381	Ø 300 - 2145 mm	030 cromo/chrome	min 10 L/min
L00382	Ø 250 - 2145 mm	030 cromo/chrome	min 10 L/min

### LO... - NEK

2 rubinetti acqua calda-fredda - 2 hot-cold water valves  
 2 Warm- und Kaltwasser Hähne - 2 robinets eau chaude-eau froide  
 2 llaves de paso agua caliente-fria - 2 Прогрессивных смесителя

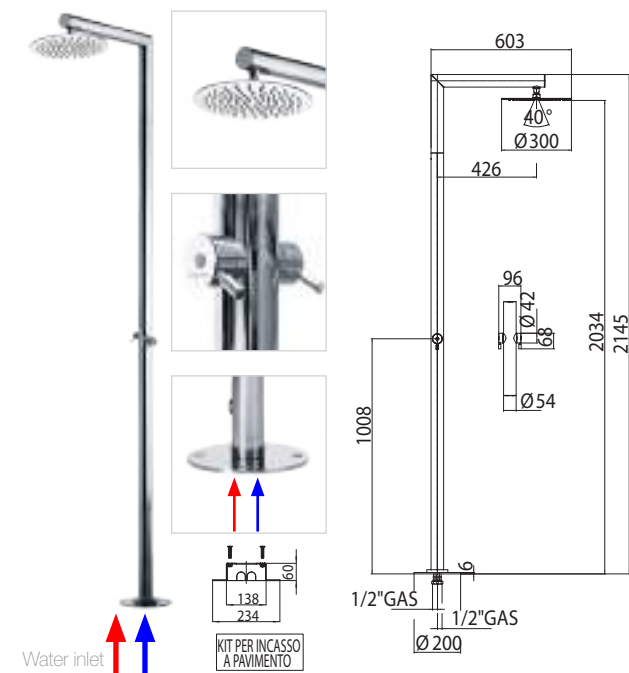

Water inlet

Packaging Box: 1 pz/pc  
 12x51,5x190

Codice/Code	Misura/Size	Finitura/Finish	Portata acqua Water flow
L00383	Ø 300 - 2145 mm	030 cromo/chrome	min 10 L/min
L00384	Ø 250 - 2145 mm	030 cromo/chrome	min 10 L/min

### LO... - NEK

Rubinetto progressivo - Progressive mixer - Progressiver Mischer  
 Mitigeur progressif - Grifo mezclador progresivo - Прогрессивных смесителя

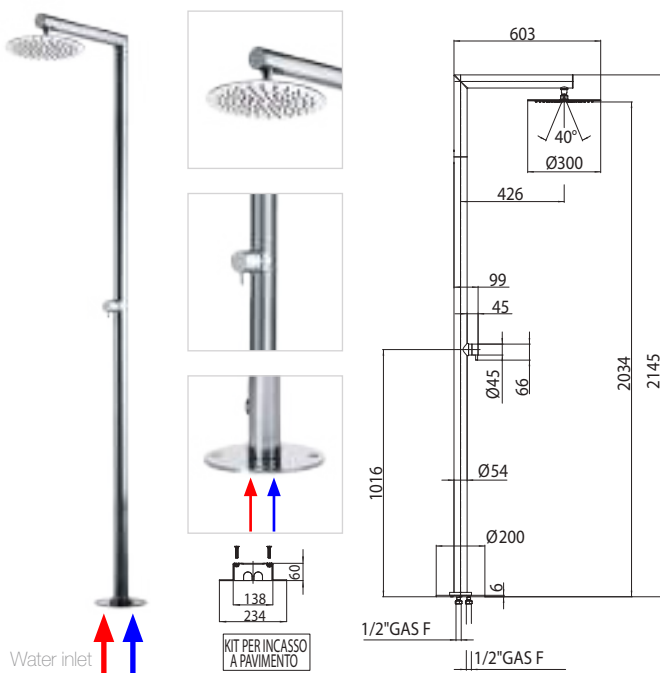

Water inlet

Packaging Box: 1 pz/pc  
 12x51,5x190

Codice/Code	Misura/Size	Finitura/Finish	Portata acqua Water flow
L00385	Ø 300 - 2145 mm	030 cromo/chrome	min 10 L/min
L00386	Ø 250 - 2145 mm	030 cromo/chrome	min 10 L/min

## L0... - TETIS

2 rubinetti progressivi - 2 progressive mixers - 2 progressive Mischer  
 2 mitigeurs progressifs - 2 grifos mezcladores progresivos  
 2 прогрессивных смесителя

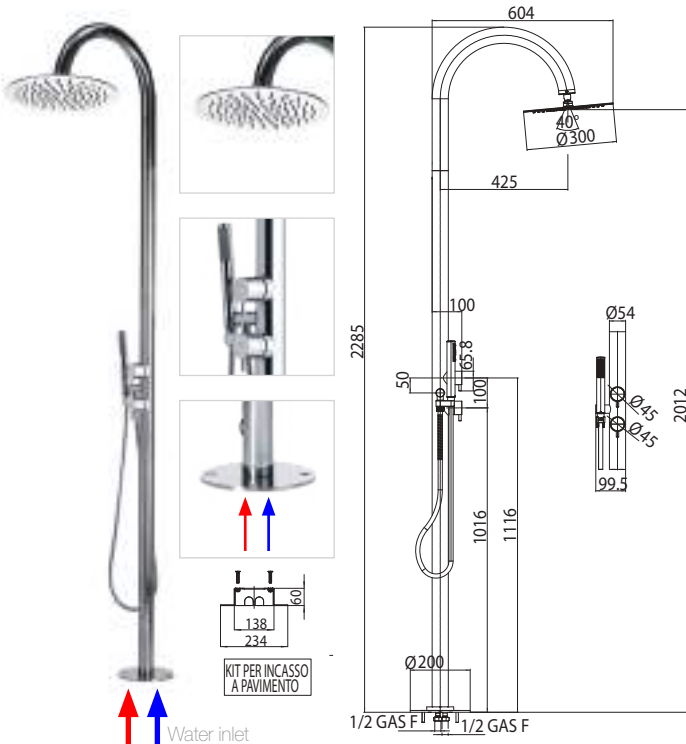

Packaging Box: 1 pz/pc  
 12x51,5x190

Codice/Code Misura/Size Finitura/Finish Portata acqua Water flow

**L00387** Ø 300 - 2285 mm 030 cromo/chrome min 10 L/min

**L00388** Ø 250 - 2285 mm 030 cromo/chrome min 10 L/min

## L0... - TETIS

2 rubinetti progressivi - 2 progressive mixers - 2 progressive Mischer  
 2 mitigeurs progressifs - 2 grifos mezcladores progresivos  
 2 прогрессивных смесителя

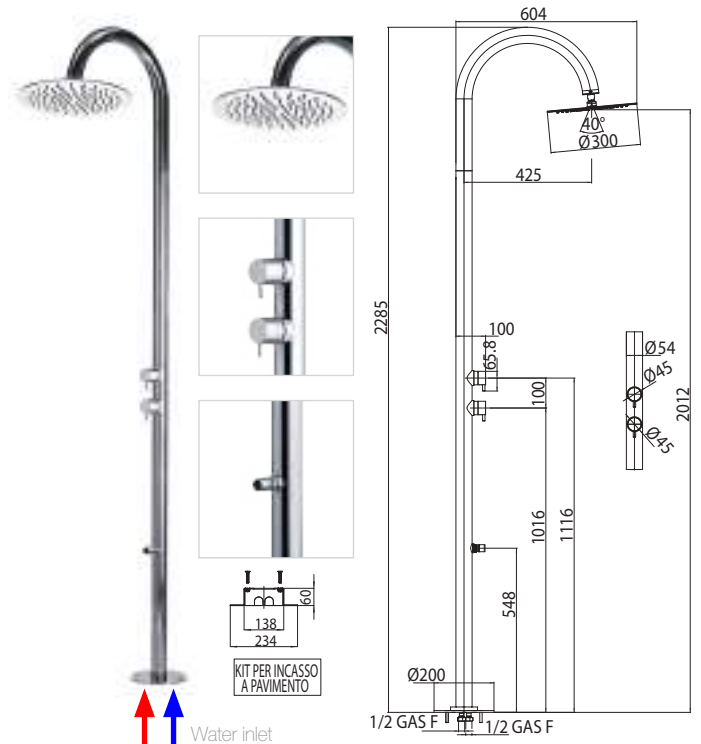

Packaging Box: 1 pz/pc  
 12x51,5x190

Codice/Code Misura/Size Finitura/Finish Portata acqua Water flow

**L00389** Ø 300 - 2285 mm 030 cromo/chrome min 10 L/min

**L00390** Ø 250 - 2285 mm 030 cromo/chrome min 10 L/min

## L0... - TETIS

2 rubinetti acqua calda-fredda - 2 hot-cold water valves  
 2 Warm- und Kaltwasser Hähne - 2 robinets eau chaude-eau froide  
 2 llaves de paso agua caliente-fría - 2 прогрессивных смесителя

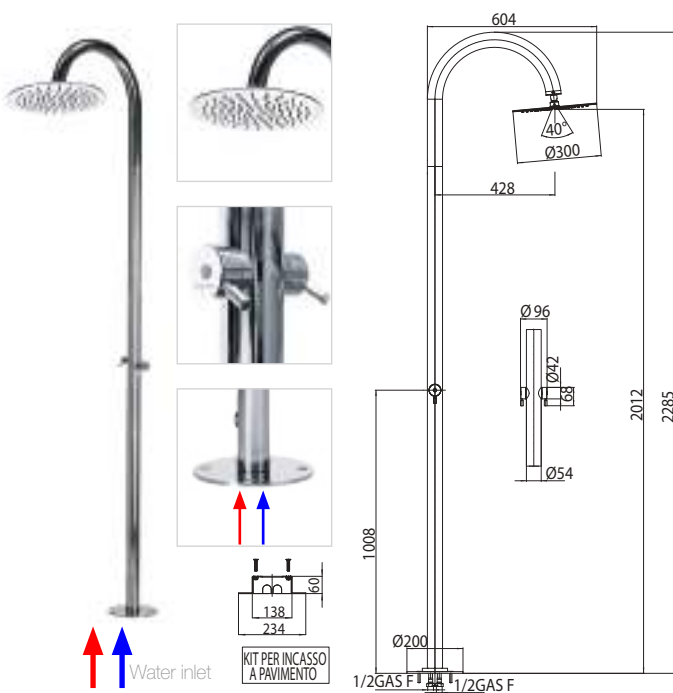

Packaging Box: 1 pz/pc  
 12x51,5x190

Codice/Code Misura/Size Finitura/Finish Portata acqua Water flow

**L00391** Ø 300 - 2285 mm 030 cromo/chrome min 10 L/min

**L00392** Ø 250 - 2285 mm 030 cromo/chrome min 10 L/min

## L0... - TETIS

Rubinetto progressivo - Progressive mixer - Progressiver Mischer  
 Mitigeur progressif - Grifo mezclador progresivo - прогрессивных смесителя



Packaging Box: 1 pz/pc  
 12x51,5x190

Codice/Code Misura/Size Finitura/Finish Portata acqua Water flow

**L00393** Ø 300 - 2285 mm 030 cromo/chrome min 10 L/min

**L00394** Ø 250 - 2285 mm 030 cromo/chrome min 10 L/min

## L0.... - TETIS

Rubinetto d'arresto - On-off valve - Wasserhahn  
 Robinet d'arrêt - Llave de paso - Запорный вентиль

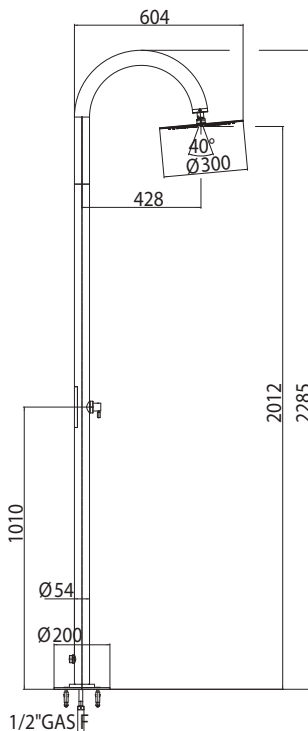

Colonna doccia con rubinetto d'arresto, attacco 1/2" F alimentazione a terra acqua fredda

Shower column with on-off valve, 1/2" F connection cold water inlet grounded in the earth

Duschsäule mit Stoppventil, 1/2" iG Wasserzufuhr Verbindung durch Bodenanschluss

Colonne de douche avec robinet d'arrêt, connexion 1/2" F alimentation eau froide par le sol

Columna de ducha con llave de paso, conexión 1/2" F alimentación agua fría por el suelo

Душевая колонна с запорным вентилем, соединение на 1/2" F с входом воды заземленным в землю



KIT PER INCASSO A PAVIMENTO



Packaging Box: 1 pz/pc  
 12x51,5x190

Codice/Code	Misura/Size	Finitura/Finish	Portata acqua Water flow
<b>L00685</b>	Ø 300 - 2285 mm	030 cromo/chrome	min 10 L/min
<b>L00686</b>	Ø 250 - 2285 mm	030 cromo/chrome	min 10 L/min

## L0.... - TETIS

Rubinetto d'arresto - On-off valve - Wasserhahn  
 Robinet d'arrêt - Llave de paso - Запорный вентиль

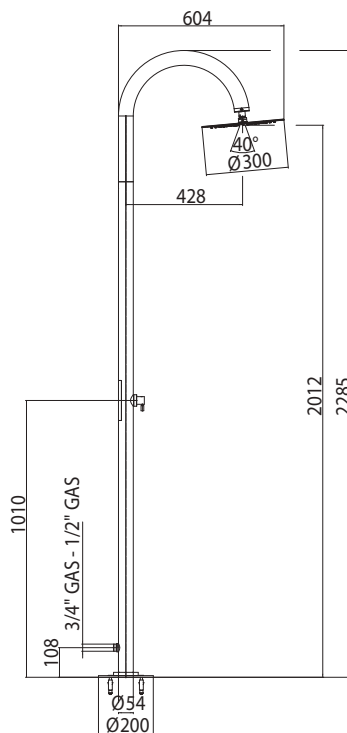

Colonna doccia con rubinetto d'arresto, attacco 3/4" M per alimentazione acqua esterna

Shower column with on-off valve, 3/4" M coupling for external water inlet

Duschsäule mit Wasserhahn und 3/4" a.G. Anschluß für Außenwasserzufuhr

Colonne douche avec robinet d'arrêt, raccord 3/4" M pour alimentation de l'eau par l'extérieur

Columna ducha con llave de paso y toma de agua exterior 3/4" M

Душевая колонна с запорным вентилем, соединение на 3/4" M для подключения наружного водоснабжения



Packaging Box: 1 pz/pc  
 12x51,5x190

Codice/Code	Misura/Size	Finitura/Finish	Portata acqua Water flow
<b>L00687</b>	Ø 300 - 2285 mm	030 cromo/chrome	min 10 L/min
<b>L00688</b>	Ø 250 - 2285 mm	030 cromo/chrome	min 10 L/min

## L0... - TETIS

Rubinetto a tempo - Self-closing valve - Selbstschluss Brausearmatur  
 Robinet temporisé - Grifo temporizado - Вентиль подачи на время

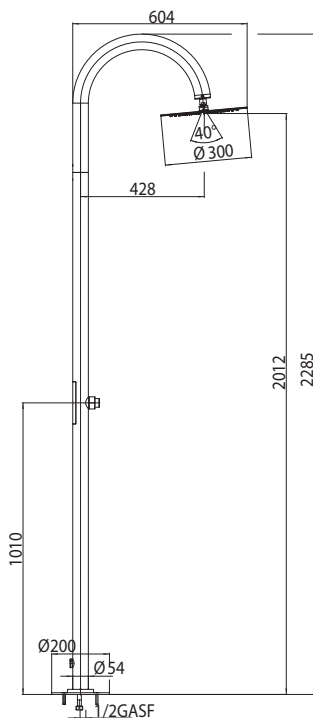

Colonna doccia con rubinetto a tempo, attacco 1/2" F alimentazione a terra acqua fredda

Shower column with self-closing valve with 1/2" F connection cold water inlet grounded in the earth

Duschsäule mit Selbstschluss-Duscharmatur, 1/2" iG Wasserzufuhr Verbindung durch Bodenanschluss

Colonne de douche avec robinet temporisé, connexion 1/2" F alimentation eau froide par le sol

Column de ducha con grifo temporizado, conexión 1/2" F suministro agua fría por el suelo

Душевая колонна с Вентиль подачи на время, соединение на 1/2" F входом воды заземленным в землю



Packaging Box: 1 pz/pc  
 12x51,5x190

Codice/Code	Misura/Size	Finitura/Finish	Portata acqua Water flow
L00689	Ø 300 - 2285 mm	030 cromo/chrome	min 10 L/min
L00690	Ø 250 - 2285 mm	030 cromo/chrome	min 10 L/min

## L0... - TETIS

Rubinetto a tempo - Self-closing valve - Selbstschluss Brausearmatur  
 Robinet temporisé - Grifo temporizado - Вентиль подачи на время

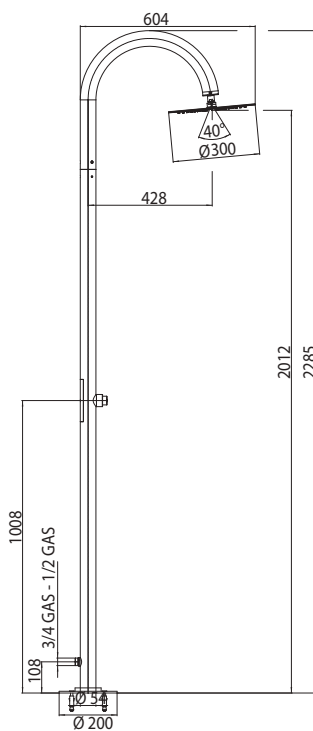

Colonna doccia con rubinetto a tempo, attacco 3/4" M per alimentazione acqua esterna

Shower column with self-closing valve, 3/4" M coupling for external water inlet

Duschsäule mit Selbstschluss Brausearmatur und 3/4" a.G. Anschluß für Außenwasserzufuhr

Colonne douche avec robinet temporisé, raccord 3/4" M pour alimentation de l'eau par l'extérieur

Column ducha con grifo temporizado y toma de agua exterior 3/4" M

Душевая колонна с временным вентилем, соединение на 3/4" M для подключения наружного водоснабжения



Packaging Box: 1 pz/pc  
 12x51,5x190

Codice/Code	Misura/Size	Finitura/Finish	Portata acqua Water flow
L00691	Ø 300 - 2285 mm	030 cromo/chrome	min 10 L/min
L00692	Ø 250 - 2285 mm	030 cromo/chrome	min 10 L/min

## LO... - OKI

Rubinetto progressivo - Progressive mixer - Progressiver Mischer  
Mitigeur progressif - Grifo mezclador progresivo - прогрессивных смесителя

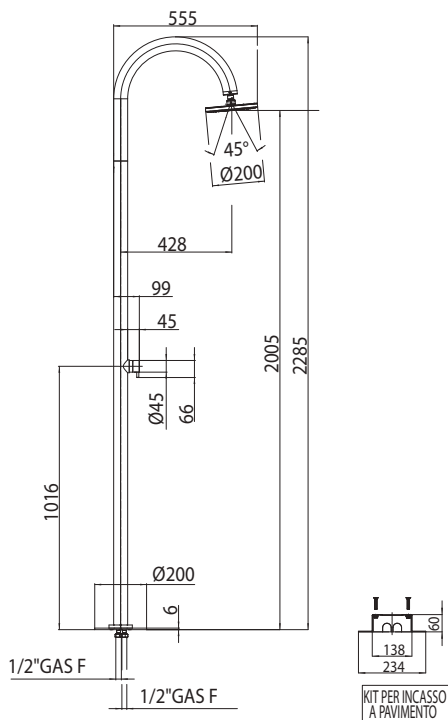

Packaging Box: 1 pz/pcs  
12x51,5x190

Codice/Code	Misura/Size	Finitura/Finish	Portata acqua/ Water flow
<b>L00376</b>	Ø 250 - 2285 mm	030 cromo/chrome	min 10 L/min
<b>L00375</b>	Ø 200 - 2285 mm	030 cromo/chrome	min 9 L/min

## LO... - OKI

2 rubinetti acqua calda-fredda - 2 hot-cold water valves - 2 Warm- und Kaltwasser Hähne  
2 robinets eau chaude-eau froide - 2 llaves de paso agua caliente-fria - 2 прогрессивных смесителя

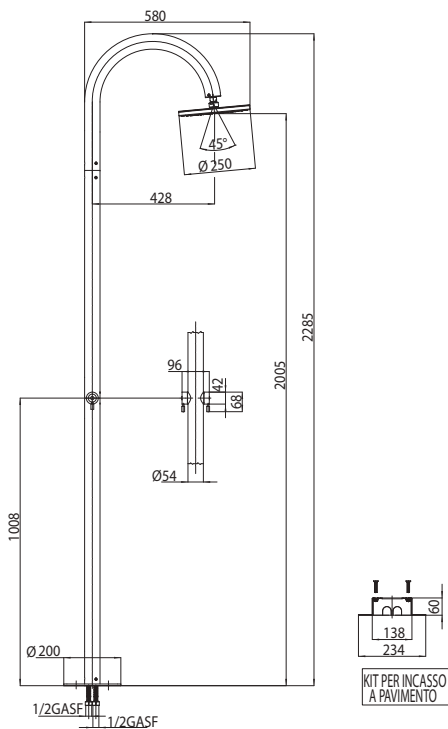

Packaging Box: 1 pz/pcs  
12x51,5x190

Codice/Code	Misura/Size	Finitura/Finish	Portata acqua/ Water flow
<b>L00818</b>	Ø 250 - 2285 mm	030 cromo/chrome	min 10 L/min
<b>L00821</b>	Ø 200 - 2285 mm	030 cromo/chrome	min 9 L/min

## LO.... - OKI

Rubinetto d'arresto - On-off valve - Wasserhahn  
 Robinet d'arrêt - Llave de paso - Запорный вентиль



Water inlet

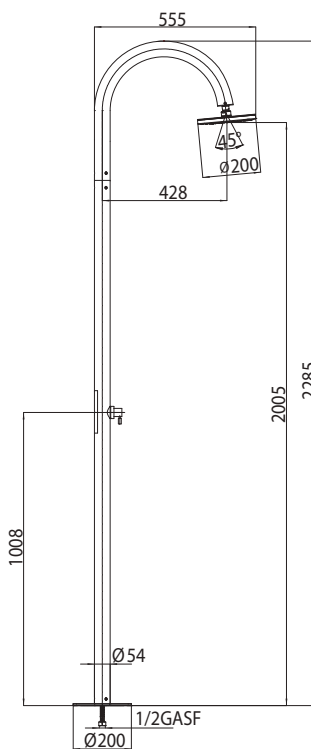

Colonna doccia con rubinetto d'arresto, attacco 1/2" F alimentazione a terra acqua fredda

Shower column with on-off valve, 1/2" F connection cold water inlet grounded in the earth

Duschsäule mit Stoppventil, 1/2" iG Wasserzufuhr Verbindung durch Bodenanschluss

Colonne de douche avec robinet d'arrêt, connexion 1/2" F pour alimentation de l'eau froide par le sol

Column de ducha con llave de paso, conexión 1/2" F alimentación agua fría por el suelo

Душевая колонна с запорным вентилем, соединение на 1/2" F с входом воды заземленным в землю



Packaging Box: 1 pz/pcs  
 12x51,5x190

Codice/Code	Misura/Size	Finitura/Finish	Portata acqua/ Water flow
<b>L00833</b>	Ø 250 - 2285 mm	030 cromo/chrome	min 10 L/min
<b>L00827</b>	Ø 200 - 2285 mm	030 cromo/chrome	min 9 L/min

## LO.... - OKI

Rubinetto d'arresto - On-off valve - Wasserhahn  
 Robinet d'arrêt - Llave de paso - Запорный вентиль



Water inlet

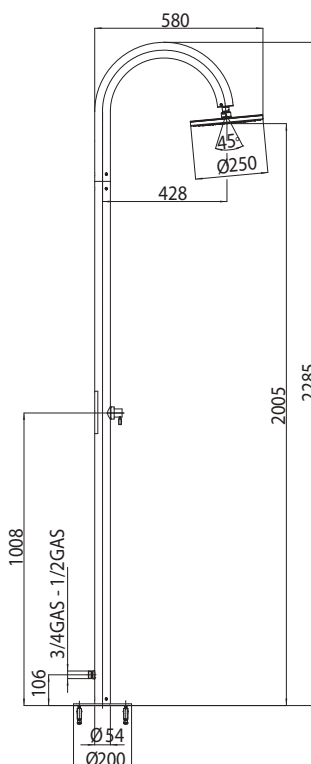

Colonna doccia con rubinetto d'arresto, attacco 3/4" M per alimentazione acqua esterna

Shower column with on-off valve, 3/4" M connection for external water inlet

Duschsäule mit Wasserhahn und 3/4" a.G. Anschluß für Außenwasserzufuhr

Colonne de douche avec robinet d'arrêt, raccord 3/4" M pour alimentation de l'eau par l'extérieur

Column ducha con llave de paso y toma de agua exterior 3/4" M

Душевая колонна с запорным вентилем, соединение на 3/4" M для подключения наружного водоснабжения



Packaging Box: 1 pz/pcs  
 12x51,5x190

Codice/Code	Misura/Size	Finitura/Finish	Portata acqua/ Water flow
<b>L00817</b>	Ø 250 - 2285 mm	030 cromo/chrome	min 10 L/min
<b>L00820</b>	Ø 200 - 2285 mm	030 cromo/chrome	min 9 L/min



## L0.... - OKI

Rubinetto a tempo - Self-closing valve - Selbstschluss Brausearmatur  
 Robinet temporisé - Grifo temporizado - Вентиль подачи на время



Water inlet

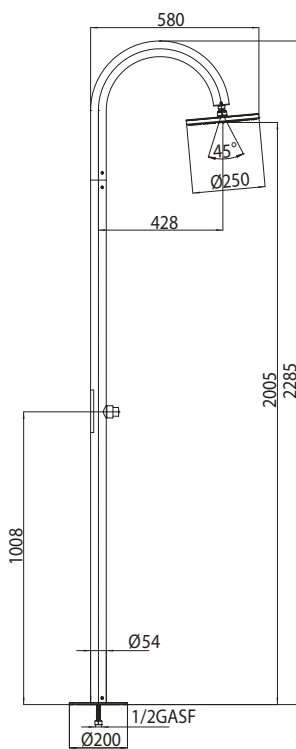

Colonna doccia con rubinetto a tempo, attacco 1/2" F alimentazione a terra acqua fredda

Shower column with self-closing valve with 1/2" F connection cold water inlet grounded in the earth

Duschsäule mit Selbstschluss-Duscharmatur, 1/2" iG Wasserzufuhr Verbindung durch Bodenanschluss

Colonne de douche avec robinet temporisé, connexion 1/2" F alimentation de l'eau froide par le sol

Column de ducha con grifo temporizado, conexión 1/2" F suministro agua fría por el suelo

Душевая колонна с Вентиль подачи на время, соединение на 1/2" F входом воды заземленным в землю



Packaging Box: 1 pz/pcs  
12x51,5x190

Codice/Code	Misura/Size	Finitura/Finish	Portata acqua/ Water flow
<b>L00829</b>	Ø 250 - 2285 mm	030 cromo/chrome	min 10 L/min
<b>L00830</b>	Ø 200 - 2285 mm	030 cromo/chrome	min 9 L/min

## L0.... - OKI

Rubinetto a tempo - Self-closing valve - Selbstschluss Brausearmatur  
 Robinet temporisé - Grifo temporizado - Вентиль подачи на время



Water inlet

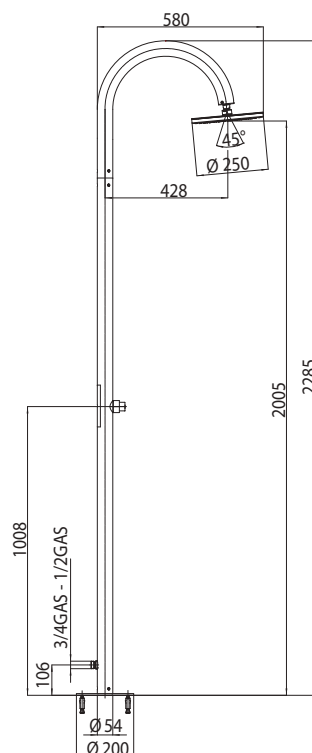

Colonna doccia con rubinetto a tempo, attacco 3/4" M per alimentazione acqua esterna

Shower column with self-closing valve, 3/4" M connection for external water inlet

Duschsäule mit Selbstschluss Brausearmatur und 3/4" a.G. Anschluß für Außenwasserzufuhr

Colonne douche avec robinet temporisé, raccord 3/4" M pour alimentation de l'eau par l'extérieur

Column ducha con grifo temporizado y toma de agua exterior 3/4" M

Душевая колонна с временным вентилем, соединение на 3/4" M для подключения наружного водоснабжения



Packaging Box: 1 pz/pcs  
12x51,5x190

Codice/Code	Misura/Size	Finitura/Finish	Portata acqua/ Water flow
<b>L00816</b>	Ø 250 - 2285 mm	030 cromo/chrome	min 10 L/min
<b>L00819</b>	Ø 200 - 2285 mm	030 cromo/chrome	min 9 L/min



### L0.... - POOL

2 rubinetti progressivi - 2 progressive mixers - 2 progressive Mischer  
2 mitigeurs progressifs - 2 grifos mezcladores progresivos  
2 прогрессивных смесителя

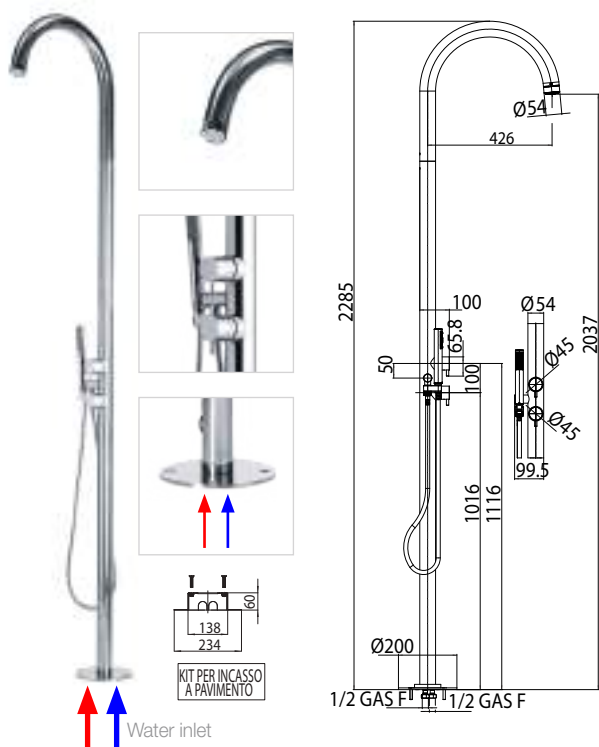

Packaging Box: 1 pz/pcs  
12x51,5x190

Codice/Code	Misura/Size	Finitura/Finish	Portata acqua/ Water flow
L00359	2285 mm	030 cromo/chrome	min 9 L/min

### L0.... - POOL

2 rubinetti progressivi - 2 progressive mixers - 2 progressive Mischer  
2 mitigeurs progressifs - 2 grifos mezcladores progresivos  
2 прогрессивных смесителя

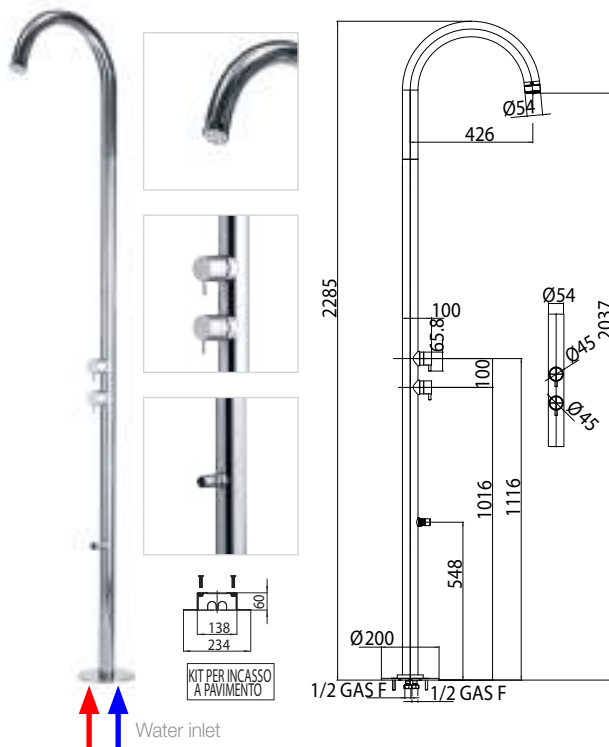

Packaging Box: 1 pz/pcs  
12x51,5x190

Codice/Code	Misura/Size	Finitura/Finish	Portata acqua/ Water flow
L00360	2285 mm	030 cromo/chrome	min 9 L/min

### L0.... - POOL

2 rubinetti acqua calda-fredda - 2 hot-cold water valves  
2 Warm- und Kaltwasser Hähne - 2 robinets eau chaude-eau froide  
2 llaves de paso agua caliente-fria - 2 прогрессивных смесителя

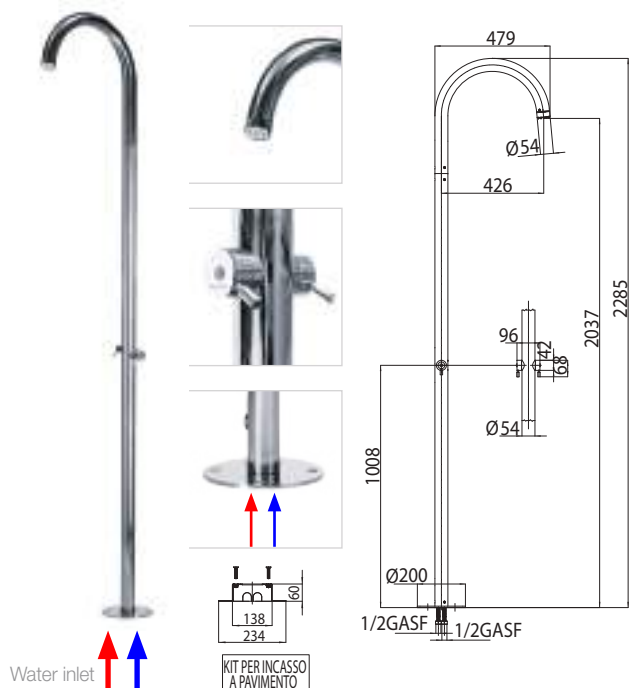

Packaging Box: 1 pz/pcs  
12x51,5x190

Codice/Code	Misura/Size	Finitura/Finish	Portata acqua/ Water flow
L00824	2285 mm	030 cromo/chrome	min 9 L/min

### L0.... - POOL

Rubinetto progressivo - Progressive mixer - Progressiver Mischer  
Mitigeur progressif - Grifo mezclador progresivo - прогрессивных смесителя

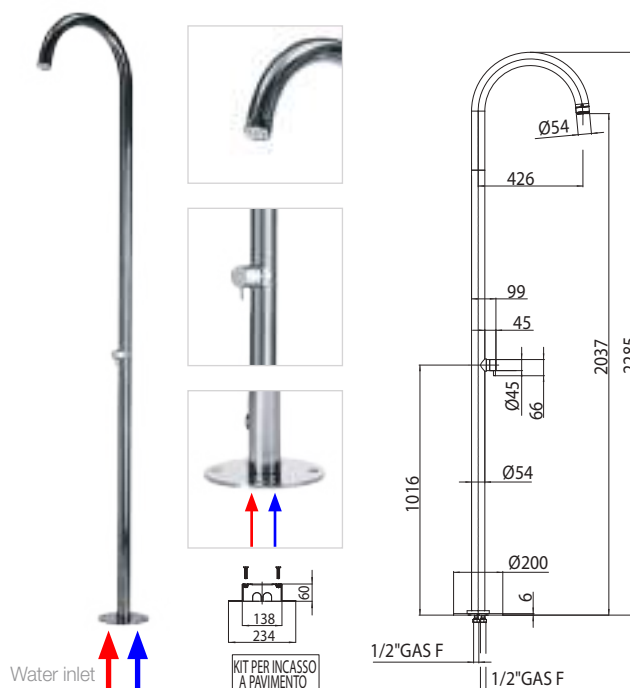

Packaging Box: 1 pz/pcs  
12x51,5x190

Codice/Code	Misura/Size	Finitura/Finish	Portata acqua/ Water flow
L00370	2285 mm	030 cromo/chrome	min 9 L/min

## L0.... - POOL

Rubinetto d'arresto - On-off valve - Wasserhahn  
 Robinet d'arrêt - Llave de paso - Запорный вентиль



Water inlet



KIT PER INCASSO  
A PAVIMENTO

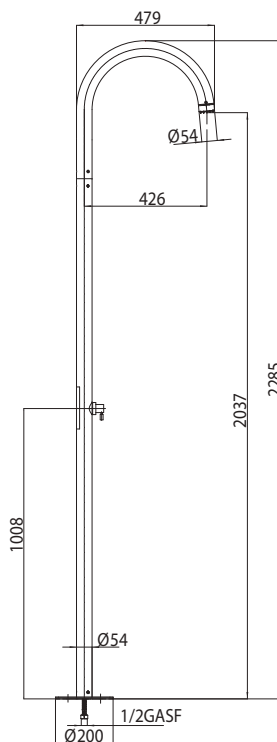

Colonna doccia con rubinetto d'arresto, attacco 1/2" F alimentazione a terra acqua fredda

Shower column with on-off valve, 1/2" F connection cold water inlet grounded in the earth

Duschsäule mit Stoppventil, 1/2" iG Wasserzufuhr Verbindung durch Bodenanschluss

Colonne de douche avec robinet d'arrêt, connexion 1/2" F pour alimentation de l'eau froide par le sol

Column de ducha con llave de paso, conexión 1/2" F alimentación agua fría por el suelo

Душевая колонна с запорным вентилем, соединение на 1/2" F с входом воды заземленным в землю



Packaging Box: 1 pz/pcs  
12x51,5x190

Codice/Code	Misura/Size	Finitura/Finish	Portata acqua/ Water flow
<b>L00826</b>	2285 mm	030 cromo/chrome	min 9 L/min

## L0.... - POOL

Rubinetto d'arresto - On-off valve - Wasserhahn  
 Robinet d'arrêt - Llave de paso - Запорный вентиль



Water inlet

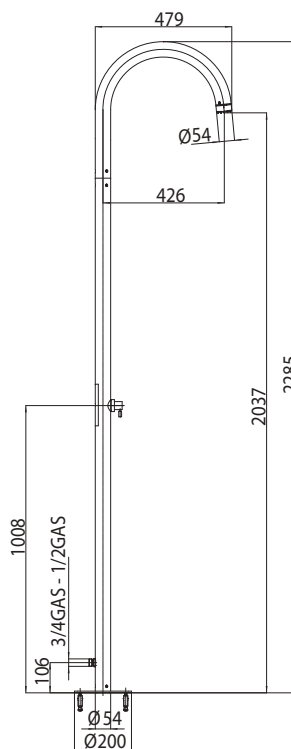

Colonna doccia con rubinetto d'arresto, attacco 3/4" M per alimentazione acqua esterna

Shower column with on-off valve, 3/4" M connection for external water inlet

Duschsäule mit Wasserhahn und 3/4" a.G. Anschluß für Außenwasserzufuhr

Colonne douche avec robinet d'arrêt, raccord 3/4" M pour alimentation de l'eau par l'extérieur

Column ducha con llave de paso y toma de agua exterior 3/4" M

Душевая колонна с запорным вентилем, соединение на 3/4" M для подключения наружного водоснабжения



Packaging Box: 1 pz/pcs  
12x51,5x190

Codice/Code	Misura/Size	Finitura/Finish	Portata acqua/ Water flow
<b>L00823</b>	2285 mm	030 cromo/chrome	min 9 L/min

## L0.... - POOL

Rubinetto a tempo - Self-closing valve - Selbstschluss Brausearmatur  
 Robinet temporisé - Grifo temporizado - Вентиль подачи на время

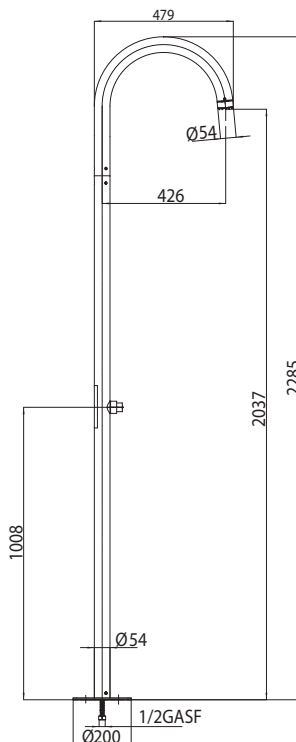

Colonna doccia con rubinetto a tempo, attacco 1/2" F alimentazione a terra acqua fredda

Shower column with self-closing valve with 1/2" F connection cold water inlet grounded in the earth

Duschsäule mit Selbstschluss-Duscharmatur, 1/2" iG Wasserzufuhr Verbindung durch Bodenanschluss

Colonne de douche avec robinet temporisé, connexion 1/2" F alimentation eau froide par le sol

Column de ducha con grifo temporizado, conexión 1/2" F suministro agua fría por el suelo

Душевая колонна с Вентиль подачи на время, соединение на 1/2" F входом воды заземленным в землю



Packaging Box: 1 pz/pcs  
 12x51,5x190

Codice/Code	Misura/Size	Finitura/Finish	Portata acqua/ Water flow
<b>L00831</b>	2285 mm	030 cromo/chrome	min 9 L/min

## L0.... - POOL

Rubinetto a tempo - Self-closing valve - Selbstschluss Brausearmatur  
 Robinet temporisé - Grifo temporizado - Вентиль подачи на время

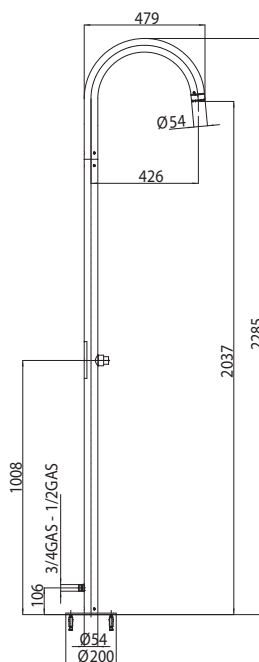

Colonna doccia con rubinetto a tempo, attacco 3/4" M per alimentazione acqua esterna

Shower column with self-closing valve, 3/4" M connection for external water inlet

Duschsäule mit Selbstschluss Brausearmatur und 3/4" a.G. Anschluß für Außenwasserzufuhr

Colonne de douche avec robinet temporisé, raccord 3/4" M pour alimentation de l'eau par l'extérieur

Column ducha con grifo temporizado y toma de agua exterior 3/4" M

Душевая колонна с временным вентилем, соединение на 3/4" M для подключения наружного водоснабжения



Packaging Box: 1 pz/pcs  
 12x51,5x190

Codice/Code	Misura/Size	Finitura/Finish	Portata acqua/ Water flow
<b>L00822</b>	2285 mm	030 cromo/chrome	min 9 L/min



## INL001 - MINIPOOL

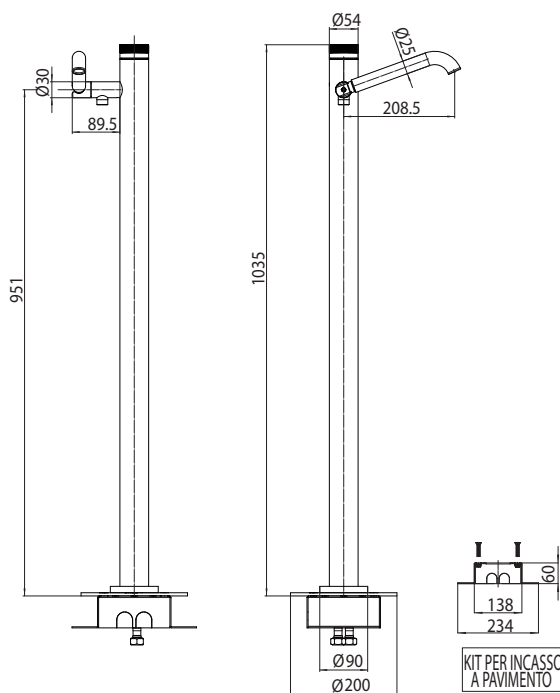

Semicolonna in acciaio inox con miscelatore progressivo e doccia  $\varnothing$  54 mm x 103 cm altezza

Stainless steel half-column with progressive mixer and hand shower  $\varnothing$  54 mm x 103 cm height

Halbsäule aus Edelstahl mit progressivem Mischer und Handbrause  $\varnothing$  54 mm x 103 cm Höhe

Demi-colonne en acier inoxydable avec mitigeur progressif et douchette  $\varnothing$  54 mm x 103 cm hauteur

Semi-columna en acero inoxidable con mezclador progresivo y mango ducha  $\varnothing$  54 mm x 103 cm altura

Смеситель из нержавеющей стали д/ванны см 103  $\varnothing$  54 mm

Set Code    Doccia/Shower    Flessibile/Flex    Finitura/Finish

**INL001**    H.103 cm    INA001 - 175 cm    030 Acciaio Lucido/Polished Stainless Steel

075 Acciaio Satinato/Matt Stainless Steel



Packaging Box: 1 pz/pcs  
41x33x116

# Colonne doccia con alimentazione da terra

## Shower columns with ground inlet

Per la corretta installazione delle Colonna Doccia da esterno (con alimentazione da terra) dovete verificare preventivamente con i vostri progettisti/installatori dove volete sia orientato il getto della colonna, poiché la direzione di installazione della colonna è determinata dall'orientamento del connettore da incasso

In order to install the outdoor shower column correctly (grounded in the earth), you must first check with your designers/installers which direction you want the water spray to come from. This is because the direction in which the shower column is facing at installation is determined by the direction of the fixing connector

Für die korrekte Installation der Duschsäule für Außenbereich (mit Bodenspeisung), muss vorher zusammen mit Ihren Planern/Installateuren überprüft werden, in welche Richtung des Wasserstrahls der Säule gerichtet werden soll, denn die Richtung für die Installation der Duschsäule wird dadurch bestimmt, wie das eingelassene Verbindungsteil ausgerichtet ist

Pour une bonne installation de la colonne douche d'extérieur (avec alimentation au sol), vous devez consulter avant vos concepteurs/installateurs au sujet de la direction d'orientation du jet de la colonne, car la direction d'installation de la colonne douche est déterminée par l'orientation du connecteur à encastrer

Para la correcta instalación de las columnas ducha para exterior (con alimentación a suelo) se debe verificar previamente con vuestros decoradores/instaladores donde se quiere esté orientado el chorro de la columna. Porque la dirección de instalación de la columna está determinada por la orientación del cuerpo empotrado

Для правильной установки Душевой Колонны (с подключением к встроенному водоснабжению) необходимо произвести предварительные замеры с Вашими проектировщиками/установщиками и определить в какую сторону будет ориентировано направление душевой струи, поскольку однажды установленная колонна, не может быть повернута из-за встроенного блока подключения к водоснабжению

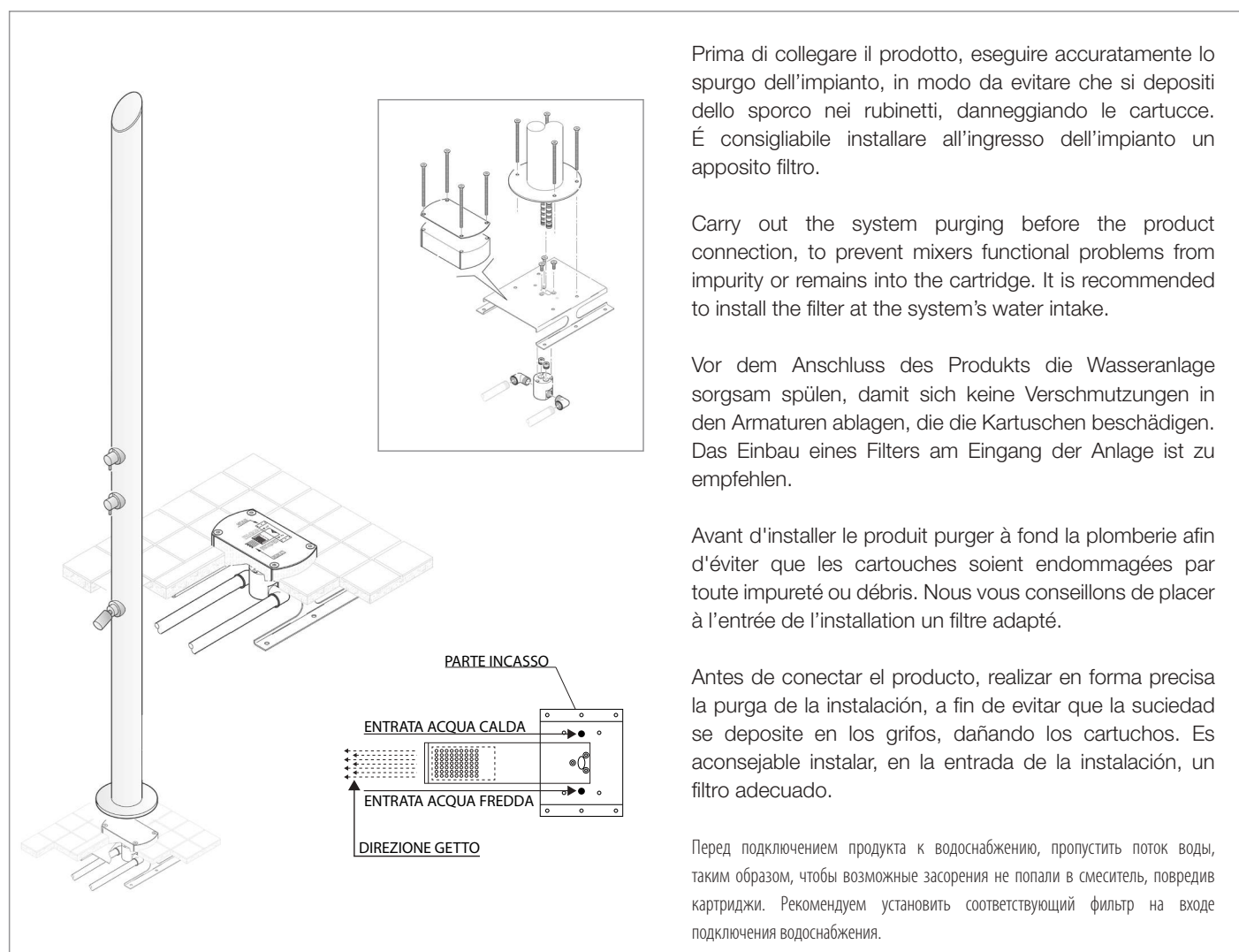

Prima di collegare il prodotto, eseguire accuratamente lo spurgo dell'impianto, in modo da evitare che si depositi dello sporco nei rubinetti, danneggiando le cartucce. È consigliabile installare all'ingresso dell'impianto un apposito filtro.

Carry out the system purging before the product connection, to prevent mixers functional problems from impurity or remains into the cartridge. It is recommended to install the filter at the system's water intake.

Vor dem Anschluss des Produkts die Wasseranlage sorgsam spülen, damit sich keine Verschmutzungen in den Armaturen ablagern, die die Kartuschen beschädigen. Das Einbau eines Filters am Eingang der Anlage ist zu empfehlen.

Avant d'installer le produit purger à fond la plomberie afin d'éviter que les cartouches soient endommagées par toute impureté ou débris. Nous vous conseillons de placer à l'entrée de l'installation un filtre adapté.

Antes de conectar el producto, realizar en forma precisa la purga de la instalación, a fin de evitar que la suciedad se deposite en los grifos, dañando los cartuchos. Es aconsejable instalar, en la entrada de la instalación, un filtro adecuado.

Перед подключением продукта к водоснабжению, пропустить поток воды, таким образом, чтобы возможные засорения не попали в смеситель, повредив картриджи. Рекомендуем установить соответствующий фильтр на входе подключения водоснабжения.

## FINITURE / FINISHINGS / OBERFLÄCHE / FINITIONS / ACABADOS / ЦВЕТ

030 acciaio lucido - polished stainless steel - Edelstahl glänzend - acier poli - acero pulido - *сталь блестящая*  
 075 acciaio opaco - mat stainless steel - Edelstahl matt - acier mat - acero opaco - *сталь матовая*

# Colonna Renovation con alimentazione acqua esterna

## Renovation shower columns with external inlet

Colonne doccia per piscina con alimentazione dell'acqua esterna con attacco da 3/4" M

Outdoor shower column with external water inlet with a 3/4" M connection

Duschsäule für den Swimmingpool mit Wasserzufuhr durch einen 3/4" a.G. Außenanschluss

Colonne de douche de piscine avec alimentation de l'eau extérieure avec connexion 3/4" M

Column de ducha para piscina, con alimentación de agua exterior con toma 3/4" M

Душевая колонна для бассейна, подключение к водоснабжению через наружное соединение на 3/4" M

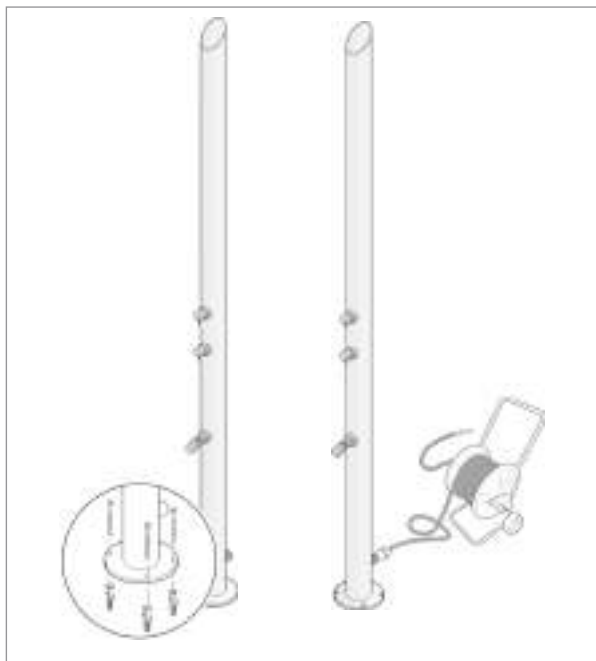

# Copertura invernale - Winter protection - Winterabdeckung

## Protection hivernale - Protección para invierno - Зимняя защита

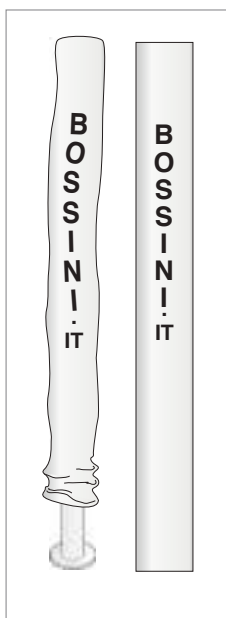

Per conservare il più a lungo possibile l'aspetto del materiale, è necessario osservare alcune regole. Durante il periodo invernale consigliamo di coprire la colonna con la protezione inclusa nella confezione

To maintain the material appearance as long as possible, a few guidelines must be followed. During the winter months, we recommend to cover the column using the protective bag included in the pack

Um die Materialien so gut wie möglich zu schützen, müssen einige grundlegende Regeln befolgt werden. Damit die Säule vor Unwetter und Feuchtigkeit geschützt ist, sollte sie im Winter mit dem in der Packung enthaltenen Schutz abgedeckt werden

Pour que le matériel conserve le plus longtemps possible son aspect d'origine, nous vous invitons à respecter quelques règles simples. Pendant l'hiver, nous vous conseillons de couvrir la colonne avec la protection qui se trouve dans l'emballage

Para mantener a largo plazo el aspecto del material, es necesario observar algunas reglas. Durante el periodo invernal, aconsejamos cubrir la columna con la protección incluida en el embalaje

Для сохранения внешнего вида колонны на длительное время, необходимо следовать одному правилу: на зимний период, закройте колонну прилагающимся защитным чехлом



BOSSINI SPA

Sede amministrativa / Head office:  
25014 Castenedolo (Brescia) Italy  
Via G. Matteotti, 170/A  
Tel. +39 030 2134 211  
Fax +39 030 2134 290  
+39 030 2134 291

info@bossini.it  
www.bossini.it

**BOSSINI**  
HIGH QUALITY  
SHOWER SYSTEMS

MADE IN ITALY