















Diametro35 Impronte

Finiture disponibili / Available finishings / Erhältliche Oberflächen / Finitions disponibles / Acabados disponibles :

CRL	CROMO / CHROME / CHROME / CHROME / CROMO
IX	SPAZZOLATO / BRUSHED / GEBÜRSTETEM / BROSSÉ / CEPILLADO
CRB	BLACK CHROME
BLX	BRUSHED BLACK CHROME
DOR	DORATO / GOLD / VERGOLDET / DOREÉ / DORADO
GOX	DORATO SPAZZOLATO / BRUSHED GOLD / GEBÜRSTETEM VERGOLDET / DOREÉ BROSSÉ / DORADO CEPILLADO
CHX	BRUSHED CHAMPAGNE
BRX	BRUSHED BRONZE
C03	BIANCO / WHITE / WEIß / BLANC / BLANCO
C04	NERO / BLACK / SCHWARZ / NOIR / NEGRO
F31	FROSTED BLACK CHROME
F32	ROSE GOLD
F33	BRUSHED ROSE GOLD
F34	DARK BRUSHED BRONZE
F36	FROSTED ROSE GOLD
F37	FROSTED CHAMPAGNE















MISCELATORI PER LAVABO
BASIN MIXERS
MISCHER FÜR WASCHTISCH
MITIGEURS POUR LAVABO
MEZCLADORES PARA LAVABO

								
PR51AU101 pag. 422	PR51AU201 pag. 423	PR51AU202 pag. 424	E0BA0105 pag. 425	PR51AV201 pag. 426	PR51AP201 pag. 427	PR51AP202 pag. 428	PR51AY101 pag. 429	PR51AY201 pag. 430
								
PR51AY102 pag. 431	PR51AY202 pag. 432	PR51AQ201 pag. 433	PR51AQ202 pag. 434	PR51AQ211 pag. 435	PR51AQ212 pag. 436			

MISCELATORI PER BIDET
BIDET MIXERS
MISCHER FÜR BIDET
MITIGEURS POUR BIDET
MEZCLADORES PARA BIDET

					
PR51BU101 pag. 437	PR51BU201 pag. 438	PR51BP201 pag. 439	PR51BP202 pag. 440	PR51BY101 pag. 441	PR51BY201 pag. 442

GRUPPI VASCA
BATH GROUPS
MISCHBATTERIE FÜR BADEWANNE
MITIGEURS POUR BAIGNOIRE
GRUPOS PARA BAÑERA

								
Q0BA6030 pag. 443	Q0BA6032 pag. 443	PR51EM101 pag. 444	PR51EM201 pag. 445	PR51ET101 pag. 446	PR51ET201 pag. 447	PR51ES101 pag. 448	PR51ES102 pag. 449	PR51ES201 pag. 450
								
PR51ES202 pag. 451	7ALF201 pag. 452	72U013 pag. 452	PR51DD201 pag. 453	PR51DD202 pag. 454				

GRUPPI DOCCIA
SHOWER GROUPS
MISCHBATTERIE FÜR DUSCHE
MITIGEURS POUR DOUCHE
GRUPOS PARA DUCHA

								
Q0BA6056 pag. 455	Q0BA6057 pag. 455	PR51FM101 pag. 456	PR51FM201 pag. 457	PR51GM101 pag. 459	PR51GM111 pag. 460	PR51GQ102 pag. 461	PR51GQ101 pag. 462	PR51GQ201 pag. 463

BATH

Diametro35 Impronte



PR28HB205
pag. 464



PR28HD103
pag. 465



PR28HD111
pag. 466



PR51HT101
pag. 467



PR51HT201
pag. 468



PR51HP102
pag. 469



PR51HP202
pag. 470



PR51HR101
pag. 471



PR51HR201
pag. 472



PR51HT102
pag. 473



PR51HT202
pag. 474



PR51HV101
pag. 475



PR51HV201
pag. 476



PR51HP101
pag. 477



PR47JA201
pag. 478



PR47JA202
pag. 479



PR47LA201
pag. 480



PR52LA221
pag. 481

BOCCHIE DI EROGAZIONE

SPOUTS

WANDAUSLÄUFE

BECS VERSEURS

CANOS



E0BA0185H03
pag. 482



E0BA0185H--
pag. 482



PR52CM201
pag. 483



PR52CM202
pag. 483



PR52CM211
pag. 484



PR52CM212
pag. 484



PR52CA201
pag. 485



PR52CA203
pag. 485



PR52CA202
pag. 486



PR52CR201
pag. 486



PR52CR211
pag. 487



PR52CP201
pag. 487



PR52CP203
pag. 488



PR52CP202
pag. 488



PR52CC101
pag. 489



PR52CC201
pag. 489



PR52CN201
pag. 490



PR52CN211
pag. 490

COMANDI REMOTI

MIXERS

MISCHER

MITIGEURS

MEZCLADORES



PR51AS201
pag. 491



PR51AS221
pag. 492



PR51AS211
pag. 493



PR51FM101
pag. 494



PR51FM201
pag. 495

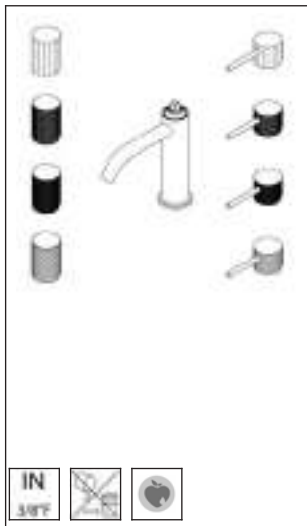

Miscelatore monocomando per lavabo

Single lever basin mixer
Waschtisch Einhandmischer
Mitigeur monocommande pour lavabo
Mezclador monomando para lavabo

- senza comando [PR51MA00x] o [PR51MA10x]
- without handle [PR51MA00x] or [PR51MA10x]
- ohne Griff [PR51MA00x] oder [PR51MA10x]
- sans commande [PR51MA00x] ou [PR51MA10x]
- sin mando [PR51MA00x] o [PR51MA10x]

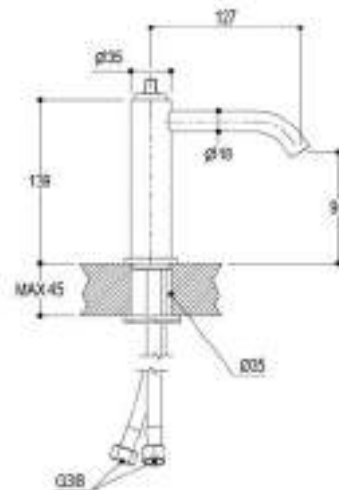

Miscelatore completo (senza comando)
Complete mixer (without handle) / Vollständige Mischer (ohne Griff) / Mitigeur complete (sans commande) / Mezclador completo (sin mando)

PR51AU201

CRL
IX, CRB, BLX, BRX, C03, C04, F31, F34
DOR, GOX, CHX, F32, F33, F36, F37

+ Comando / Handles / Griff / Commande / Mando

Comando PRISMA
Handle PRISMA / Griff PRISMA /
Commande PRISMA / Mando PRISMA



PR51MA001 PR51MA101

CRL
IX, CRB, BLX, BRX, C03, C04, F31, F34
DOR, GOX, CHX, F32, F33, F36, F37

Comando TRATTO
Handle TRATTO / Griff TRATTO /
Commande TRATTO / Mando TRATTO



PR51MA002 PR51MA102

CRL
IX, CRB, BLX, BRX, C03, C04, F31, F34
DOR, GOX, CHX, F32, F33, F36, F37

Comando RIGO
Handle RIGO / Griff RIGO /
Commande RIGO / Mando RIGO



PR51MA003 PR51MA103

CRL
IX, CRB, BLX, BRX, C03, C04, F31, F34
DOR, GOX, CHX, F32, F33, F36, F37

Comando PUNTO
Handle PUNTO / Griff PUNTO /
Commande PUNTO / Mando PUNTO



PR51MA004 PR51MA104

CRL
IX, CRB, BLX, BRX, C03, C04, F31, F34
DOR, GOX, CHX, F32, F33, F36, F37

Accessori / Accessories / Zubehör / Accessoires / Accesorios

Prolunghe / Extensions / Verlängerungen / Rallonges / Prolongadoras & Ricambi / Spare parts / Ersatzteile / Pièces de rechange / Recambios

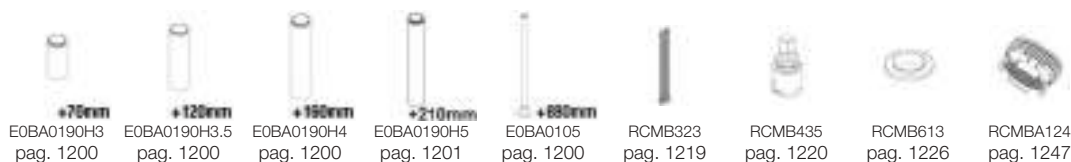

Miscelatore e comando venduti separatamente
Mixer and handle sold separately / Mischer und Griff separat verkauf / Mitigeur et manette vendus séparément / Mezclador y mando vendidos separatamente



Miscelatore monocomando per lavabo
Single lever basin mixer
Waschtisch Einhandmischer
Mitigeur monocommande pour lavabo
Mezclador monomando para lavabo



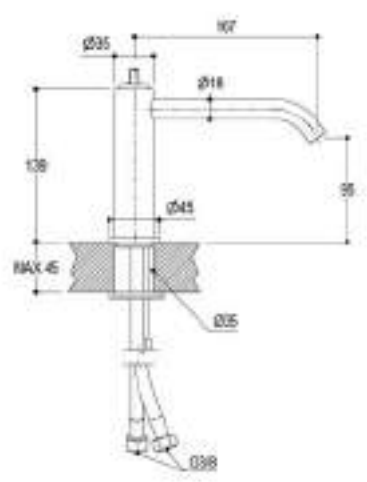

senza comando [PR51MA00x] o [PR51MA10x]
without handle [PR51MA00x] or [PR51MA10x]
ohne Griff [PR51MA00x] oder [PR51MA10x]
sans commande [PR51MA00x] ou [PR51MA10x]
sin mando [PR51MA00x] o [PR51MA10x]



Miscelatore completo (senza comando)
Complete mixer (without handle) / Vollständige Mischer (ohne Griff) / Mitigeur complete (sans commande) / Mezclador completo (sin mando)

PR51AU202 **CRL**
IX, CRB, BLX, BRX, C03, C04, F31, F34
DOR, GOX, CHX, F32, F33, F36, F37

+ Comando / Handles / Griff / Commande / Mando

<p>Comando PRISMA <i>Handle PRISMA / Griff PRISMA / Commande PRISMA / Mando PRISMA</i></p>	<p>Comando TRATTO <i>Handle TRATTO / Griff TRATTO / Commande TRATTO / Mando TRATTO</i></p>	<p>Comando RIGO <i>Handle RIGO / Griff RIGO / Commande RIGO / Mando RIGO</i></p>	<p>Comando PUNTO <i>Handle PUNTO / Griff PUNTO / Commande PUNTO / Mando PUNTO</i></p>
			
<p>PR51MA001 PR51MA101</p> <hr/> <p>CRL IX, CRB, BLX, BRX, C03, C04, F31, F34 DOR, GOX, CHX, F32, F33, F36, F37</p>	<p>PR51MA002 PR51MA102</p> <hr/> <p>CRL IX, CRB, BLX, BRX, C03, C04, F31, F34 DOR, GOX, CHX, F32, F33, F36, F37</p>	<p>PR51MA003 PR51MA103</p> <hr/> <p>CRL IX, CRB, BLX, BRX, C03, C04, F31, F34 DOR, GOX, CHX, F32, F33, F36, F37</p>	<p>PR51MA004 PR51MA104</p> <hr/> <p>CRL IX, CRB, BLX, BRX, C03, C04, F31, F34 DOR, GOX, CHX, F32, F33, F36, F37</p>

Accessori / Accessories / Zubehör / Accessoires / Accesorios

Prolunghe / Extensions / Verlängerungen / Rallonges / Prolongadoras & Ricambi / Spare parts / Ersatzteile / Pièces de rechange / Recambios

								
+70mm	+120mm	+150mm	+210mm	+630mm				
E0BA0190H3 pag. 1200	E0BA0190H3.5 pag. 1200	E0BA0190H4 pag. 1200	E0BA0190H5 pag. 1201	E0BA0105 pag. 1200	RCMB323 pag. 1219	RCMB435 pag. 1220	RCMB613 pag. 1226	RCMBA124 pag. 1247

Miscelatore e comando venduti separatamente
Mixer and handle sold separately / Mischer und Griff separat verkauft / Mitigeur et manette vendus séparément / Mezclador y mando vendidos separatamente

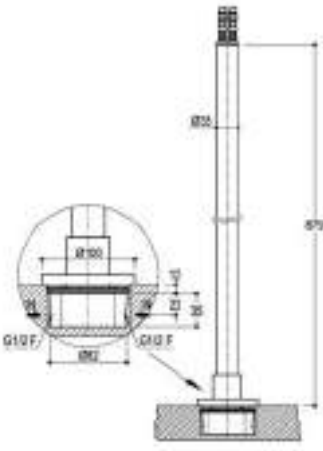
 <p>IN OUT</p>	<p>Prolunga da terra per corpo miscelatore <i>Standing floor extension for single lever body mixer</i> <i>Bodenstandrohrverlängerung</i> <i>Rallonge en pied à brancher au sol pour mitigeur</i> <i>Prolongador de suelo para cuerpo de mezclador</i></p> <hr/> <p>completo di parti interne per Diametro35-0123(L-CL-S-CS)-0124(L-CL-S-CS) ·Diametro35 Impronte-PR51-AU101-AU201-AU202 ·Diametro35 S-PR52- AA101-AA201-AA202 ·Diametro35 Elegance-PR54- AA101-AA201-AA202 <i>with inner parts for ·Diametro35- 0123(L-CL-S-CS)-0124(L-CL-S-CS) ·Diametro35 Impronte-PR51- AU101-AU201-AU202 ·Diametro35 S-PR52- AA101-AA201-AA202 ·Diametro35 Elegance-PR54- AA101-AA201-AA202 mit UP-Teilen für ·Diametro35- 0123(L-CL-S-CS)-0124(L-CL-S-CS) ·Diametro35 Impronte-PR51- AU101-AU201-AU202 ·Diametro35 S-PR52- AA101-AA201-AA202 ·Diametro35 Elegance-PR54- AA101-AA201-AA202 avec parties internes pour ·Diametro35- 0123(L-CL-S-CS)-0124(L-CL-S-CS) ·Diametro35 Impronte-PR51- AU101-AU201-AU202 ·Diametro35 S-PR52- AA101-AA201-AA202 ·Diametro35 Elegance-PR54- AA101-AA201-AA202</i> completo de partes internas para ·Diametro35-0123(L-CL-S-CS)-0124(L-CL-S-CS) ·Diametro35 Impronte-PR51-AU101-AU201-AU202 ·Diametro35 S-PR52- AA101-AA201-AA202 ·Diametro35 Elegance-PR54- AA101-AA201-AA202</p>	
--	---	---

	<p>Parti esterne <i>Outer parts / Fertigset / Parties externes / Partes externas</i></p>	<p>E0BA0105EST</p> <p>CRL IX, CRB, BLX, BRX, C03, C04, F31, F34 DOR, GOX, CHX, F32, F33, F36, F37</p>
---	--	---

	<p>Parti da incasso <i>Built-in parts / UP-teile / Parties internes / Partes internas</i></p>	<p>RCMB201</p>
--	---	-----------------------

<p>Miscelatore completo <i>Complete mixer / Vollständige Mischer / Mitigeur complete / Mezclador completo</i></p>	<p>E0BA0105</p> <p>CRL IX, CRB, BLX, BRX, C03, C04, F31, F34 DOR, GOX, CHX, F32, F33, F36, F37</p>
---	--





Miscelatore monocomando sopra piano per lavabo
Exposed single lever basin mixer
Waschtisch Standmischbatterie
Mitigeur monocommande sur-plan pour lavabo
Mezclador monomando sobre encimera



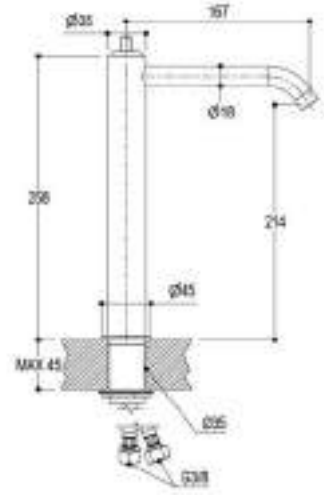

senza comando [PR51MA00x] o [PR51MA10x]
without handle [PR51MA00x] or [PR51MA10x]
ohne Griff [PR51MA00x] oder [PR51MA10x]
sans commande [PR51MA00x] ou [PR51MA10x]
sin mando [PR51MA00x] o [PR51MA10x]



Miscelatore completo (senza comando)
Complete mixer (without handle) / Vollständige Mischer (ohne Griff) / Mitigeur complete (sans commande) / Mezclador completo (sin mando)

PR51AV201 **CRL**
IX, CRB, BLX, BRX, C03, C04, F31, F34
DOR, GOX, CHX, F32, F33, F36, F37

+ Comando / Handles / Griff / Commande / Mando

<p>Comando PRISMA <i>Handle PRISMA / Griff PRISMA / Commande PRISMA / Mando PRISMA</i></p>	<p>Comando TRATTO <i>Handle TRATTO / Griff TRATTO / Commande TRATTO / Mando TRATTO</i></p>	<p>Comando RIGO <i>Handle RIGO / Griff RIGO / Commande RIGO / Mando RIGO</i></p>	<p>Comando PUNTO <i>Handle PUNTO / Griff PUNTO / Commande PUNTO / Mando PUNTO</i></p>
			
<p>PR51MA001 PR51MA101</p> <hr/> <p>CRL IX, CRB, BLX, BRX, C03, C04, F31, F34 DOR, GOX, CHX, F32, F33, F36, F37</p>	<p>PR51MA002 PR51MA102</p> <hr/> <p>CRL IX, CRB, BLX, BRX, C03, C04, F31, F34 DOR, GOX, CHX, F32, F33, F36, F37</p>	<p>PR51MA003 PR51MA103</p> <hr/> <p>CRL IX, CRB, BLX, BRX, C03, C04, F31, F34 DOR, GOX, CHX, F32, F33, F36, F37</p>	<p>PR51MA004 PR51MA104</p> <hr/> <p>CRL IX, CRB, BLX, BRX, C03, C04, F31, F34 DOR, GOX, CHX, F32, F33, F36, F37</p>

Accessori / Accessories / Zubehör / Accessoires / Accesorios

Ricambi / Spare parts / Ersatzteile / Pièces de rechange / Recambios

			
RCMB341 pag. 1219	RCMB435 pag. 1220	RCMB613 pag. 1226	RCMBA124 pag. 1247

Miscelatore e comando venduti separatamente
Mixer and handle sold separately / Mischer und Griff separat verkauft / Mitigeur et manette vendus séparément / Mezclador y mando vendidos separadamente

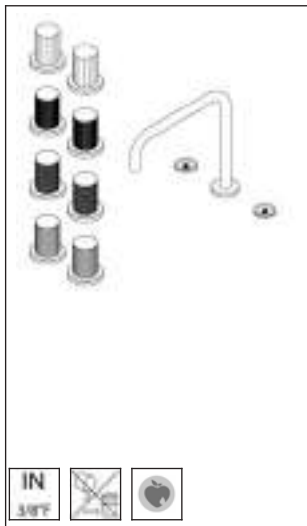

Gruppo a tre fori per lavabo
 Three holes basin group
 Dreiloch Waschtischbatterie
 Mélangeur pour lavabo
 Mezclador bimando para lavabo

senza comandi [PR51MB01x]
 - without handles [PR51MB01x]
 - ohne Griffe [PR51MB01x]
 - sans commandes [PR51MB01x]
 - sin mandos [PR51MB01x]

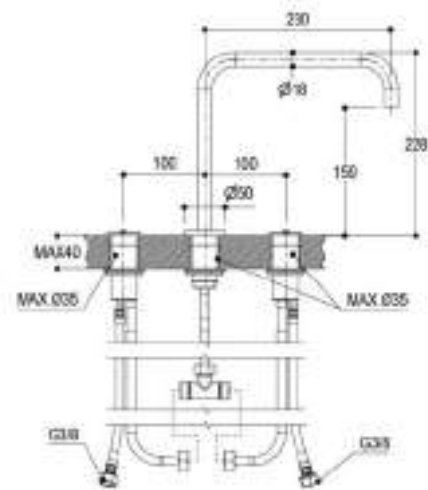

Miscelatore completo (senza comando)
 Complete mixer (without handle) / Vollständige
 Mischer (ohne Griff) / Mitigeur complete (sans
 commande) / Mezclador completo (sin mando)

PR51AP201

CRL
 IX, CRB, BLX, BRX, C03, C04, F31, F34
 DOR, GOX, CHX, F32, F33, F36, F37

+ Comando / Handles / Griff / Comande / Mando

Comandi PRISMA
 Handles PRISMA / Griffe PRISMA /
 Commandes PRISMA / Mandos
 PRISMA



PR51MB011

CRL
 IX, CRB, BLX, BRX,
 C03, C04, F31, F34
 DOR, GOX, CHX, F32,
 F33, F36, F37

Comandi TRATTO
 Handles TRATTO / Griffe TRATTO
 / Commandes TRATTO / Mandos
 TRATTO



PR51MB012

CRL
 IX, CRB, BLX, BRX,
 C03, C04, F31, F34
 DOR, GOX, CHX, F32,
 F33, F36, F37

Comandi RIGO
 Handles RIGO / Griffe RIGO /
 Commandes RIGO / Mandos
 RIGO



PR51MB013

CRL
 IX, CRB, BLX, BRX,
 C03, C04, F31, F34
 DOR, GOX, CHX, F32,
 F33, F36, F37

Comandi PUNTO
 Handles PUNTO / Griffe PUNTO /
 Commandes PUNTO / Mandos
 PUNTO



PR51MB014

CRL
 IX, CRB, BLX, BRX,
 C03, C04, F31, F34
 DOR, GOX, CHX, F32,
 F33, F36, F37

Accessori / Accessories / Zubehör / Accessoires / Accesorios

Ricambi / Spare parts / Ersatzteile / Pièces de rechange / Recambios



RCMB068 pag. 1216 RCMB307 pag. 1218 RCMB972 pag. 1242 RCMBA069 pag. 1245 RCMBA124 pag. 1247 RCMBA135 pag. 1248 RCMBA149 pag. 1249

Miscelatore e comandi venduti separatamente
 Mixer and handles sold separately / Mischer und Griffe separat verkauf / Mélangeur et manettes vendus séparément / Mezclador y mandos vendidos separatamente



Gruppo a tre fori per lavabo
Three holes basin group
Dreiloch Waschtischbatterie
Mélangeur pour lavabo
Mezclador bimando para lavabo

senza comandi [PR51MB01x]
without handles [PR51MB01x]
ohne Griffe [PR51MB01x]
sans commandes [PR51MB01x]
sin mandos [PR51MB01x]







Miscelatore completo (senza comando)
Complete mixer (without handle) / Vollständige Mischer (ohne Griff) / Mitigeur complete (sans commande) / Mezclador completo (sin mando)

PR51AP202

CRL
IX, CRB, BLX, BRX, C03, C04, F31, F34
DOR, GOX, CHX, F32, F33, F36, F37

+ Comando / Handles / Griff / Commande / Mando



<p>Comandi PRISMA <i>Handles PRISMA / Griffe PRISMA / Commandes PRISMA / Mandos PRISMA</i></p>  <p>PR51MB011</p> <hr/> <p>CRL IX, CRB, BLX, BRX, C03, C04, F31, F34 DOR, GOX, CHX, F32, F33, F36, F37</p>	<p>Comandi TRATTO <i>Handles TRATTO / Griffe TRATTO / Commandes TRATTO / Mandos TRATTO</i></p>  <p>PR51MB012</p> <hr/> <p>CRL IX, CRB, BLX, BRX, C03, C04, F31, F34 DOR, GOX, CHX, F32, F33, F36, F37</p>	<p>Comandi RIGO <i>Handles RIGO / Griffe RIGO / Commandes RIGO / Mandos RIGO</i></p>  <p>PR51MB013</p> <hr/> <p>CRL IX, CRB, BLX, BRX, C03, C04, F31, F34 DOR, GOX, CHX, F32, F33, F36, F37</p>	<p>Comandi PUNTO <i>Handles PUNTO / Griffe PUNTO / Commandes PUNTO / Mandos PUNTO</i></p>  <p>PR51MB014</p> <hr/> <p>CRL IX, CRB, BLX, BRX, C03, C04, F31, F34 DOR, GOX, CHX, F32, F33, F36, F37</p>
---	---	--	--

Accessori / Accessories / Zubehör / Accessoires / Accesorios

Ricambi / Spare parts / Ersatzteile / Pièces de rechange / Recambios

						
RCMB068 pag. 1216	RCMB307 pag. 1218	RCMB972 pag. 1242	RCMBA069 pag. 1245	RCMBA124 pag. 1247	RCMBA135 pag. 1248	RCMBA149 pag. 1249

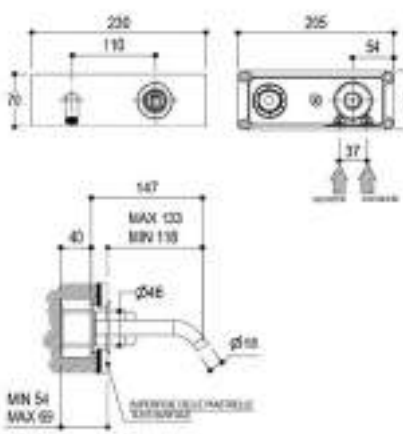
Miscelatore e comandi venduti separatamente
Mixer and handles sold separately / Mischer und Griffe separat verkauft / Mélangeur et manettes vendus séparément / Mezclador y mandos vendidos separatamente





	<p>Miscelatore monocomando ad incasso per lavabo <i>Built-in single lever basin mixer</i> <i>UP-Einhandmischer für Waschbecken</i> <i>Mitigeur monocommande à encastrer pour lavabo</i> <i>Mezclador monomando empotrado para lavabo</i></p> <hr/> <p>_ canna SX Lmax=133mm _ piastra esterna _ completo di parti interne _ senza comando [PR51MC10x] <i>_ spout SX Lmax=133mm _ external plate _ complete of inner parts _ without handle [PR51MC10x]</i> <i>_ Einlaufrohr Lj Lmax=133mm _ Montageplatte _ komplett mit UP-Teilen _ ohne Griff [PR51MC10x]</i> <i>_ Bec SX Lmax=133mm _ plaque externe _ complet avec parties internes _ sans commande [PR51MC10x]</i> <i>_ caño SX Lmax=133mm _ plancha externa _ completo de partes internas _ sin mando [PR51MC10x]</i></p>	
		

	<p>Parti esterne <i>Outer parts / Fertigset / Parties externes / Partes externas</i></p>	<p>PR51AZ101 CRL IX, CRB, BLX, BRX, C03, C04, F31, F34 DOR, GOX, CHX, F32, F33, F36, F37</p>
---	--	--

	<p>Parti da incasso <i>Built-in parts / UP-teile / Parties internes / Partes internas</i></p>	<p>E0BA0115SX</p>
--	---	--------------------------

<p>Miscelatore completo (senza comando) <i>Complete mixer (without handle) / Vollständige Mischer (ohne Griff) / Mitigeur complete (sans commande) / Mezclador completo (sin mando)</i></p>	<p>PR51AY101 CRL IX, CRB, BLX, BRX, C03, C04, F31, F34 DOR, GOX, CHX, F32, F33, F36, F37</p>
---	--

+ Comando / Handles / Griff / Commande / Mando

<p>Comando PRISMA <i>Handle PRISMA / Griff PRISMA / Commande PRISMA / Mando PRISMA</i></p>  <p>PR51MC101</p> <p>CRL IX, CRB, BLX, BRX, C03, C04, F31, F34 DOR, GOX, CHX, F32, F33, F36, F37</p>	<p>Comando TRATTO <i>Handle TRATTO / Griff TRATTO / Commande TRATTO / Mando TRATTO</i></p>  <p>PR51MC102</p> <p>CRL IX, CRB, BLX, BRX, C03, C04, F31, F34 DOR, GOX, CHX, F32, F33, F36, F37</p>	<p>Comando RIGO <i>Handle RIGO / Griff RIGO / Commande RIGO / Mando RIGO</i></p>  <p>PR51MC103</p> <p>CRL IX, CRB, BLX, BRX, C03, C04, F31, F34 DOR, GOX, CHX, F32, F33, F36, F37</p>	<p>Comando PUNTO <i>Handle PUNTO / Griff PUNTO / Commande PUNTO / Mando PUNTO</i></p>  <p>PR51MC104</p> <p>CRL IX, CRB, BLX, BRX, C03, C04, F31, F34 DOR, GOX, CHX, F32, F33, F36, F37</p>
--	--	--	---

Accessori / Accessories / Zubehör / Accessoires / Accesorios

Prolunghe / Extensions / Verlängerungen / Rallonges / Prolongadoras & Ricambi / Spare parts / Ersatzteile / Pièces de rechange / Recambios

 <p>+20mm RCMB054H1 pag. 1202</p>	 <p>+40mm RCMB054H2 pag. 1202</p>	 <p>RCMB015 pag. 1213</p>	 <p>RCMB742 pag. 1231</p>	 <p>RCMB124 pag. 1247</p>	 <p>RCMB126H1 pag. 1247</p>	 <p>RCMB140 pag. 1249</p>
--	--	--	--	--	--	--

Miscelatore e comando venduti separatamente
Mixer and handle sold separately / Mischer und Griff separat verkauf / Mitigeur et manette vendus séparément / Mezclador y mando vendidos separatamente



Miscelatore monocomando ad incasso per lavabo
Built-in single lever basin mixer
UP-Einhandmischer für Waschbecken
Mitigeur monocommande à encastrer pour lavabo
Mezclador monomando empotrado para lavabo

_ canna SX Lmax=133mm _ completo di parti interne _ senza comando [PR51MC10x]
spout SX Lmax=133mm _ complete of inner parts _ without handle [PR51MC10x]
Einlaufrohr LI Lmax=133mm _ komplett mit UP-Teilen _ ohne Griff [PR51MC10x]
Bec SX Lmax=133mm _ complet avec parties internes _ sans commande [PR51MC10x]
caño SX Lmax=133mm _ completo de partes internas _ sin mando [PR51MC10x]







Parti esterne
Outer parts / Fertigset / Parties externes / Partes externas

PR51AZ201

CRL
IX, CRB, BLX, BRX, C03, C04, F31, F34
DOR, GOX, CHX, F32, F33, F36, F37



Parti da incasso
Built-in parts / UP-teile / Parties internes / Partes internas



E0BA0115SX

Miscelatore completo (senza comando)
Complete mixer (without handle) / Vollständige Mischer (ohne Griff) / Mitigeur complete (sans commande) / Mezclador completo (sin mando)

PR51AY201

CRL
IX, CRB, BLX, BRX, C03, C04, F31, F34
DOR, GOX, CHX, F32, F33, F36, F37

+ Comando / Handles / Griff / Commande / Mando

<p>Comando PRISMA <i>Handle PRISMA / Griff PRISMA / Commande PRISMA / Mando PRISMA</i></p>  <p>PR51MC101</p> <hr/> <p>CRL IX, CRB, BLX, BRX, C03, C04, F31, F34 DOR, GOX, CHX, F32, F33, F36, F37</p>	<p>Comando TRATTO <i>Handle TRATTO / Griff TRATTO / Commande TRATTO / Mando TRATTO</i></p>  <p>PR51MC102</p> <hr/> <p>CRL IX, CRB, BLX, BRX, C03, C04, F31, F34 DOR, GOX, CHX, F32, F33, F36, F37</p>	<p>Comando RIGO <i>Handle RIGO / Griff RIGO / Commande RIGO / Mando RIGO</i></p>  <p>PR51MC103</p> <hr/> <p>CRL IX, CRB, BLX, BRX, C03, C04, F31, F34 DOR, GOX, CHX, F32, F33, F36, F37</p>	<p>Comando PUNTO <i>Handle PUNTO / Griff PUNTO / Commande PUNTO / Mando PUNTO</i></p>  <p>PR51MC104</p> <hr/> <p>CRL IX, CRB, BLX, BRX, C03, C04, F31, F34 DOR, GOX, CHX, F32, F33, F36, F37</p>
--	--	---	---

Accessori / Accessories / Zubehör / Accessoires / Accesorios

Prolunghe / Extensions / Verlängerungen / Rallonges / Prolongadoras & Ricambi / Spare parts / Ersatzteile / Pièces de rechange / Recambios

							
+25mm	+40mm						
RCMB054H1 pag. 1202	RCMB054H2 pag. 1202	RCMB015 pag. 1213	RCMB742 pag. 1231	RCMBA124 pag. 1247	RCMBA126H1 pag. 1247	RCMBA133 pag. 1248	RCMBA146 pag. 1249

Miscelatore e comando venduti separatamente
Mixer and handle sold separately / Mischer und Griff separat verkauft / Mitigeur et manette vendus séparément / Mezclador y mando vendidos separatamente

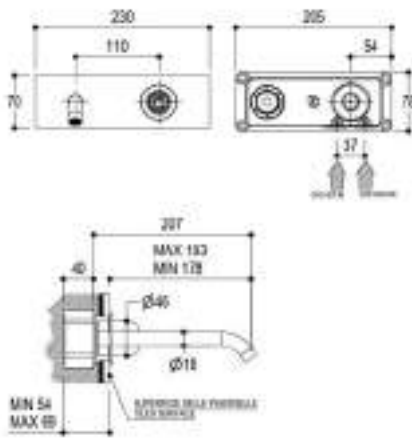



	<p>Miscelatore monocomando ad incasso per lavabo <i>Built-in single lever basin mixer</i> <i>UP-Einhandmischer für Waschbecken</i> <i>Mitigeur monocommande à encastrer pour lavabo</i> <i>Mezclador monomando empotrado para lavabo</i></p> <p>_ canna SX Lmax=193mm _ piastra esterna _ completo di parti interne _ senza comando [PR51MC10x] <i>_ spout SX Lmax=193mm _ external plate _ complete of inner parts _ without handle [PR51MC10x]</i> <i>_ Einlaufrohr Lj Lmax=193mm _ Montageplatte _ komplett mit UP-Teilen _ ohne Griff [PR51MC10x]</i> <i>_ Bec SX Lmax=193mm _ plaque externe _ complet avec parties internes _ sans commande [PR51MC10x]</i> <i>_ caño SX Lmax=193mm _ plancha externa _ completo de partes internas _ sin mando [PR51MC10x]</i></p>	
---	---	---

	<p>Parti esterne <i>Outer parts / Fertigset / Parties externes / Partes externas</i></p>	<p>PR51AZ102 CRL IX, CRB, BLX, BRX, C03, C04, F31, F34 DOR, GOX, CHX, F32, F33, F36, F37</p>
---	--	--

	<p>Parti da incasso <i>Built-in parts / UP-teile / Parties internes / Partes internas</i></p>	<p>E0BA0115SX</p>
--	---	--------------------------

<p>Miscelatore completo (senza comando) <i>Complete mixer (without handle) / Vollständige Mischer (ohne Griff) / Mitigeur complete (sans commande) / Mezclador completo (sin mando)</i></p>	<p>PR51AY102 CRL IX, CRB, BLX, BRX, C03, C04, F31, F34 DOR, GOX, CHX, F32, F33, F36, F37</p>
---	--

+ Comando / Handles / Griff / Commande / Mando

<p>Comando PRISMA <i>Handle PRISMA / Griff PRISMA / Commande PRISMA / Mando PRISMA</i></p>  <p>PR51MC101</p> <p>CRL IX, CRB, BLX, BRX, C03, C04, F31, F34 DOR, GOX, CHX, F32, F33, F36, F37</p>	<p>Comando TRATTO <i>Handle TRATTO / Griff TRATTO / Commande TRATTO / Mando TRATTO</i></p>  <p>PR51MC102</p> <p>CRL IX, CRB, BLX, BRX, C03, C04, F31, F34 DOR, GOX, CHX, F32, F33, F36, F37</p>	<p>Comando RIGO <i>Handle RIGO / Griff RIGO / Commande RIGO / Mando RIGO</i></p>  <p>PR51MC103</p> <p>CRL IX, CRB, BLX, BRX, C03, C04, F31, F34 DOR, GOX, CHX, F32, F33, F36, F37</p>	<p>Comando PUNTO <i>Handle PUNTO / Griff PUNTO / Commande PUNTO / Mando PUNTO</i></p>  <p>PR51MC104</p> <p>CRL IX, CRB, BLX, BRX, C03, C04, F31, F34 DOR, GOX, CHX, F32, F33, F36, F37</p>
--	--	--	---

Accessori / Accessories / Zubehör / Accessoires / Accesorios

Prolunghe / Extensions / Verlängerungen / Rallonges / Prolongadoras & Ricambi / Spare parts / Ersatzteile / Pièces de rechange / Recambios

 <p>+20mm RCMB054H1 pag. 1202</p>	 <p>+40mm RCMB054H2 pag. 1202</p>	 <p>RCMB015 pag. 1213</p>	 <p>RCMB742 pag. 1231</p>	 <p>RCMB124 pag. 1247</p>	 <p>RCMB126H2 pag. 1247</p>	 <p>RCMB140 pag. 1249</p>
--	--	--	--	--	--	--

Miscelatore e comando venduti separatamente
Mixer and handle sold separately / Mischer und Griff separat verkauf / Mitigeur et manette vendus séparément / Mezclador y mando vendidos separatamente



Miscelatore monocomando ad incasso per lavabo
Built-in single lever basin mixer
UP-Einhandmischer für Waschbecken
Mitigeur monocommande à encastrer pour lavabo
Mezclador monomando empotrado para lavabo

_ canna SX Lmax=193mm _ completo di parti interne _ senza comando [PR51MC10x]
spout SX Lmax=193mm _ complete of inner parts _ without handle [PR51MC10x]
Einlaufrohr LI Lmax=193mm _ komplett mit UP-Teilen _ ohne Griff [PR51MC10x]
Bec SX Lmax=193mm _ complet avec parties internes _ sans commande [PR51MC10x]
caño SX Lmax=193mm _ completo de partes internas _ sin mando [PR51MC10x]

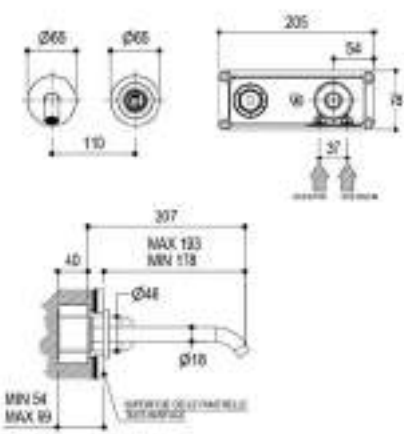





Parti esterne
Outer parts / Fertigset / Parties externes / Partes externas

PR51AZ202

CRL
IX, CRB, BLX, BRX, C03, C04, F31, F34
DOR, GOX, CHX, F32, F33, F36, F37



Parti da incasso
Built-in parts / UP-teile / Parties internes / Partes internas





E0BA0115SX

Miscelatore completo (senza comando)
Complete mixer (without handle) / Vollständige Mischer (ohne Griff) / Mitigeur complete (sans commande) / Mezclador completo (sin mando)

PR51AY202

CRL
IX, CRB, BLX, BRX, C03, C04, F31, F34
DOR, GOX, CHX, F32, F33, F36, F37

+ Comando / Handles / Griff / Commande / Mando

<p>Comando PRISMA <i>Handle PRISMA / Griff PRISMA / Commande PRISMA / Mando PRISMA</i></p>  <p>PR51MC101</p> <hr/> <p>CRL IX, CRB, BLX, BRX, C03, C04, F31, F34 DOR, GOX, CHX, F32, F33, F36, F37</p>	<p>Comando TRATTO <i>Handle TRATTO / Griff TRATTO / Commande TRATTO / Mando TRATTO</i></p>  <p>PR51MC102</p> <hr/> <p>CRL IX, CRB, BLX, BRX, C03, C04, F31, F34 DOR, GOX, CHX, F32, F33, F36, F37</p>	<p>Comando RIGO <i>Handle RIGO / Griff RIGO / Commande RIGO / Mando RIGO</i></p>  <p>PR51MC103</p> <hr/> <p>CRL IX, CRB, BLX, BRX, C03, C04, F31, F34 DOR, GOX, CHX, F32, F33, F36, F37</p>	<p>Comando PUNTO <i>Handle PUNTO / Griff PUNTO / Commande PUNTO / Mando PUNTO</i></p>  <p>PR51MC104</p> <hr/> <p>CRL IX, CRB, BLX, BRX, C03, C04, F31, F34 DOR, GOX, CHX, F32, F33, F36, F37</p>
--	--	---	---

Accessori / Accessories / Zubehör / Accessoires / Accesorios

Prolunghe / Extensions / Verlängerungen / Rallonges / Prolongadoras & Ricambi / Spare parts / Ersatzteile / Pièces de rechange / Recambios

							
+25mm	+40mm						
RCMB054H1 pag. 1202	RCMB054H2 pag. 1202	RCMB015 pag. 1213	RCMB742 pag. 1231	RCMBA124 pag. 1247	RCMBA126H2 pag. 1247	RCMBA133 pag. 1248	RCMBA146 pag. 1249

Miscelatore e comando venduti separatamente
Mixer and handle sold separately / Mischer und Griff separat verkauft / Mitigeur et manette vendus séparément / Mezclador y mando vendidos separatamente



Gruppo a tre fori ad incasso per lavabo
 Built-in three holes basin group
 Dreiloch UP-Waschtischbatterie
 Mélangeur à encastrer pour lavabo
 Mezclador bimando empotrado para lavabo

canna Lmax=128mm _ completo di parti interne _ senza comandi [PR51MB00x]
 spout Lmax=128mm _ complete of inner parts _ without handles [PR51MB00x]
 Einlaufrohr Lmax=128mm _ komplett mit UP-Teilen _ ohne Griffe [PR51MB00x]
 Bec Lmax=128mm _ complet avec parties internes _ sans commandes [PR51MB00x]
 caño Lmax=128mm _ completo de partes internas _ sin mandos [PR51MB00x]

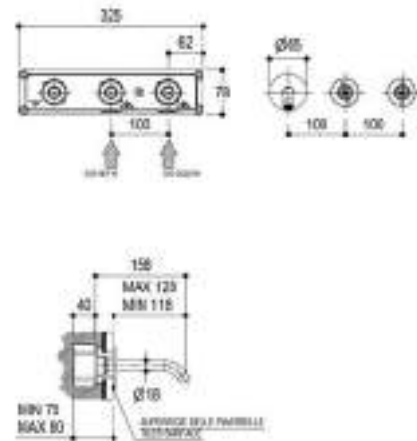

Parti esterne
 Outer parts / Fertigset / Parties externes / Partes externas

PR51AR201 **CRL**
 IX, CRB, BLX, BRX, C03, C04, F31, F34
 DOR, GOX, CHX, F32, F33, F36, F37

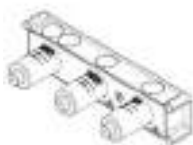

Parti da incasso
 Built-in parts / UP-teile / Parties internes / Partes internas

PM0000G

Miscelatore completo (senza comando)
 Complete mixer (without handle) / Vollständige Mischer (ohne Griff) / Mitigeur complete (sans commande) / Mezclador completo (sin mando)

PR51AQ201 **CRL**
 IX, CRB, BLX, BRX, C03, C04, F31, F34
 DOR, GOX, CHX, F32, F33, F36, F37

+ Comando / Handles / Griff / Commande / Mando

Comandi PRISMA
 Handles PRISMA / Griffe PRISMA /
 Commandes PRISMA / Mandos PRISMA



PR51MB001

CRL
 IX, CRB, BLX, BRX,
 C03, C04, F31, F34
 DOR, GOX, CHX, F32,
 F33, F36, F37

Comandi TRATTO
 Handles TRATTO / Griffe TRATTO /
 Commandes TRATTO / Mandos TRATTO



PR51MB002

CRL
 IX, CRB, BLX, BRX,
 C03, C04, F31, F34
 DOR, GOX, CHX, F32,
 F33, F36, F37

Comandi RIGO
 Handles RIGO / Griffe RIGO /
 Commandes RIGO / Mandos RIGO



PR51MB003

CRL
 IX, CRB, BLX, BRX,
 C03, C04, F31, F34
 DOR, GOX, CHX, F32,
 F33, F36, F37

Comandi PUNTO
 Handles PUNTO / Griffe PUNTO /
 Commandes PUNTO / Mandos PUNTO



PR51MB004

CRL
 IX, CRB, BLX, BRX,
 C03, C04, F31, F34
 DOR, GOX, CHX, F32,
 F33, F36, F37

Accessori / Accessories / Zubehör / Accessoires / Accesorios

Ricambi / Spare parts / Ersatzteile / Pièces de rechange / Recambios



RCMA124 pag. 1247 RCMA126H1 pag. 1247 RCMA133 pag. 1248 RCMA150 pag. 1249

Miscelatore e comandi venduti separatamente
 Mixer and handles sold separately / Mischer und Griffe separat verkauft / Mélangeur et manettes vendus séparément / Mezclador y mandos vendidos separatamente



Gruppo a tre fori ad incasso per lavabo
*Built-in three holes basin group
 Dreiloch UP-Waschtischbatterie
 Mélangeur à encastrer pour lavabo
 Mezclador bimando empotrado para lavabo*

canna Lmax=188mm _ completo di parti interne_ senza comandi [PR51MB00x]
*spout Lmax=188mm _ complete of inner parts _ without handles [PR51MB00x]
 Einlaufrohr Lmax=188mm _ komplett mit UP-Teilen _ ohne Griffe [PR51MB00x]
 Bec Lmax=188mm _ complet avec parties internes _ sans commandes [PR51MB00x]
 caño Lmax=188mm _ completo de partes internas _ sin mandos [PR51MB00x]*







Parti esterne
Outer parts / Fertigset / Parties externes / Partes externas

PR51AR202 **CRL**
IX, CRB, BLX, BRX, C03, C04, F31, F34
DOR, GOX, CHX, F32, F33, F36, F37







Parti da incasso
Built-in parts / UP-teile / Parties internes / Partes internas

PM0000G

Miscelatore completo (senza comando)
Complete mixer (without handle) / Vollständige Mischer (ohne Griff) / Mitigeur complete (sans commande) / Mezclador completo (sin mando)

PR51AQ202 **CRL**
IX, CRB, BLX, BRX, C03, C04, F31, F34
DOR, GOX, CHX, F32, F33, F36, F37

+ Comando / Handles / Griff / Commande / Mando

<p>Comandi PRISMA <i>Handles PRISMA / Griffe PRISMA / Commandes PRISMA / Mandos PRISMA</i></p>  <p>PR51MB001</p> <p>CRL IX, CRB, BLX, BRX, C03, C04, F31, F34 DOR, GOX, CHX, F32, F33, F36, F37</p>	<p>Comandi TRATTO <i>Handles TRATTO / Griffe TRATTO / Commandes TRATTO / Mandos TRATTO</i></p>  <p>PR51MB002</p> <p>CRL IX, CRB, BLX, BRX, C03, C04, F31, F34 DOR, GOX, CHX, F32, F33, F36, F37</p>	<p>Comandi RIGO <i>Handles RIGO / Griffe RIGO / Commandes RIGO / Mandos RIGO</i></p>  <p>PR51MB003</p> <p>CRL IX, CRB, BLX, BRX, C03, C04, F31, F34 DOR, GOX, CHX, F32, F33, F36, F37</p>	<p>Comandi PUNTO <i>Handles PUNTO / Griffe PUNTO / Commandes PUNTO / Mandos PUNTO</i></p>  <p>PR51MB004</p> <p>CRL IX, CRB, BLX, BRX, C03, C04, F31, F34 DOR, GOX, CHX, F32, F33, F36, F37</p>
--	--	---	---

Accessori / Accessories / Zubehör / Accessoires / Accesorios

Ricambi / Spare parts / Ersatzteile / Pièces de rechange / Recambios

 RCMA124 pag. 1247	 RCMA126H2 pag. 1247	 RCMA133 pag. 1248	 RCMA150 pag. 1249
---	---	---	---

Miscelatore e comandi venduti separatamente
Mixer and handles sold separately / Mischer und Griffe separat verkauft / Mélangeur et manettes vendus séparément / Mezclador y mandos vendidos separatamente



Gruppo a tre fori ad incasso per lavabo
 Built-in three holes basin group
 Dreiloch UP-Waschtischbatterie
 Mélangeur à encastrer pour lavabo
 Mezclador bimando empotrado para lavabo

canna L=max=128mm _ completo di parti interne _ senza comandi [PR51MB00x]
 spout L=max=128mm _ complete of inner parts _ without handles [PR51MB00x]
 Einlaufrohr L=max=128mm _ komplett mit UP-Teilen _ ohne Griffe [PR51MB00x]
 Bec L=max=128mm _ complet avec parties internes _ sans commandes [PR51MB00x]
 caño L=max=128mm _ completo de partes internas _ sin mandos [PR51MB00x]

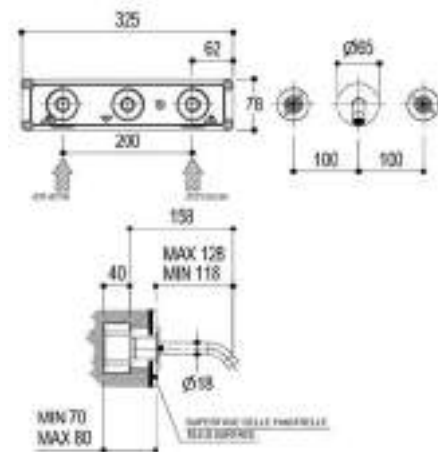

Parti esterne
 Outer parts / Fertigset / Parties externes / Partes externas

PR51AR201 CRL
 IX, CRB, BLX, BRX, C03, C04, F31, F34
 DOR, GOX, CHX, F32, F33, F36, F37



Parti da incasso
 Built-in parts / UP-teile / Parties internes / Partes internas

PM0000H

Miscelatore completo (senza comando)
 Complete mixer (without handle) / Vollständige Mischer (ohne Griff) / Mitigeur complete (sans commande) / Mezclador completo (sin mando)

PR51AQ211 CRL
 IX, CRB, BLX, BRX, C03, C04, F31, F34
 DOR, GOX, CHX, F32, F33, F36, F37

+ Comando / Handles / Griff / Commande / Mando

Comandi PRISMA
 Handles PRISMA / Griffe PRISMA /
 Commandes PRISMA / Mandos PRISMA



PR51MB001

CRL
 IX, CRB, BLX, BRX,
 C03, C04, F31, F34
 DOR, GOX, CHX, F32,
 F33, F36, F37

Comandi TRATTO
 Handles TRATTO / Griffe TRATTO /
 Commandes TRATTO / Mandos TRATTO



PR51MB002

CRL
 IX, CRB, BLX, BRX,
 C03, C04, F31, F34
 DOR, GOX, CHX, F32,
 F33, F36, F37

Comandi RIGO
 Handles RIGO / Griffe RIGO /
 Commandes RIGO / Mandos RIGO



PR51MB003

CRL
 IX, CRB, BLX, BRX,
 C03, C04, F31, F34
 DOR, GOX, CHX, F32,
 F33, F36, F37

Comandi PUNTO
 Handles PUNTO / Griffe PUNTO /
 Commandes PUNTO / Mandos PUNTO



PR51MB004

CRL
 IX, CRB, BLX, BRX,
 C03, C04, F31, F34
 DOR, GOX, CHX, F32,
 F33, F36, F37

Accessori / Accessories / Zubehör / Accessoires / Accesorios

Ricambi / Spare parts / Ersatzteile / Pièces de rechange / Recambios



RCMA124
 pag. 1247



RCMA126H1
 pag. 1247



RCMA133
 pag. 1248



RCMA151
 pag. 1249

Miscelatore e comandi venduti separatamente

Mixer and handles sold separately / Mischer und Griffe separat verkauft / Mélangeur et manettes vendus séparément / Mezclador y mandos vendidos separatamente



Gruppo a tre fori ad incasso per lavabo
*Built-in three holes basin group
 Dreiloch UP-Waschtischbatterie
 Mélangeur à encastrer pour lavabo
 Mezclador bimando empotrado para lavabo*

canna Lmax=188mm _ completo di parti interne_ senza comandi [PR51MB00x]
*spout Lmax=188mm _ complete of inner parts _ without handles [PR51MB00x]
 Einlaufrohr Lmax=188mm _ komplett mit UP-Teilen _ ohne Griffe [PR51MB00x]
 Bec Lmax=188mm _ complet avec parties internes _ sans commandes [PR51MB00x]
 caño Lmax=188mm _ completo de partes internas _ sin mandos [PR51MB00x]*

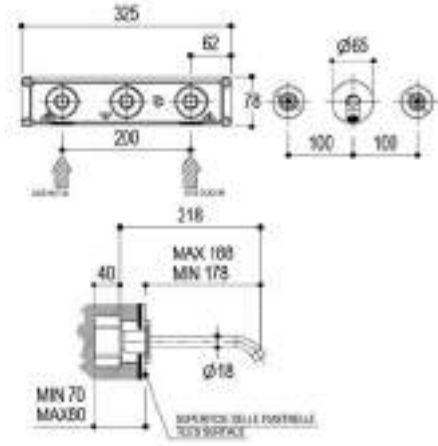





Parti esterne
Outer parts / Fertigset / Parties externes / Partes externas

PR51AR202 CRL
IX, CRB, BLX, BRX, C03, C04, F31, F34
DOR, GOX, CHX, F32, F33, F36, F37



Parti da incasso
Built-in parts / UP-teile / Parties internes / Partes internas





PM0000H

Miscelatore completo (senza comando)
Complete mixer (without handle) / Vollständige Mischer (ohne Griff) / Mitigeur complete (sans commande) / Mezclador completo (sin mando)

PR51AQ212

CRL
IX, CRB, BLX, BRX, C03, C04, F31, F34
DOR, GOX, CHX, F32, F33, F36, F37

+ Comando / Handles / Griff / Commande / Mando

<p>Comandi PRISMA <i>Handles PRISMA / Griffe PRISMA / Commandes PRISMA / Mandos PRISMA</i></p>  <p>PR51MB001</p> <p>CRL IX, CRB, BLX, BRX, C03, C04, F31, F34 DOR, GOX, CHX, F32, F33, F36, F37</p>	<p>Comandi TRATTO <i>Handles TRATTO / Griffe TRATTO / Commandes TRATTO / Mandos TRATTO</i></p>  <p>PR51MB002</p> <p>CRL IX, CRB, BLX, BRX, C03, C04, F31, F34 DOR, GOX, CHX, F32, F33, F36, F37</p>	<p>Comandi RIGO <i>Handles RIGO / Griffe RIGO / Commandes RIGO / Mandos RIGO</i></p>  <p>PR51MB003</p> <p>CRL IX, CRB, BLX, BRX, C03, C04, F31, F34 DOR, GOX, CHX, F32, F33, F36, F37</p>	<p>Comandi PUNTO <i>Handles PUNTO / Griffe PUNTO / Commandes PUNTO / Mandos PUNTO</i></p>  <p>PR51MB004</p> <p>CRL IX, CRB, BLX, BRX, C03, C04, F31, F34 DOR, GOX, CHX, F32, F33, F36, F37</p>
--	--	---	---

Accessori / Accessories / Zubehör / Accessoires / Accesorios

Ricambi / Spare parts / Ersatzteile / Pièces de rechange / Recambios

 RCMBA124 pag. 1247	 RCMBA126H2 pag. 1247	 RCMBA133 pag. 1248	 RCMBA151 pag. 1249
--	--	--	--

Miscelatore e comandi venduti separatamente
Mixer and handles sold separately / Mischer und Griffe separat verkauft / Mélangeur et manettes vendus séparément / Mezclador y mandos vendidos separatamente

	<p>Miscelatore monocomando per bidet <i>Single lever bidet mixer</i> <i>Einhandbidetmischer</i> <i>Mitigeur monocommande pour bidet</i> <i>Mezclador monomando para bidet</i></p> <p>— senza comando [PR51MA00x] o [PR51MA10x] — <i>without handle [PR51MA00x] or [PR51MA10x]</i> — <i>ohne Griff [PR51MA00x] oder [PR51MA10x]</i> — <i>sans commande [PR51MA00x] ou [PR51MA10x]</i> — <i>sin mando [PR51MA00x] o [PR51MA10x]</i></p>	
--	---	--



Miscelatore completo (senza comando)
Complete mixer (without handle) / Vollständige Mischer (ohne Griff) / Mitigeur complete (sans commande) / Mezclador completo (sin mando)

PR51BU201 **CRL**
IX, CRB, BLX, BRX, C03, C04, F31, F34
DOR, GOX, CHX, F32, F33, F36, F37

+ **Comando / Handles / Griff / Commande / Mando**

<p>Comando PRISMA <i>Handle PRISMA / Griff PRISMA / Commande PRISMA / Mando PRISMA</i></p> <p>PR51MA001 PR51MA101</p> <p>CRL IX, CRB, BLX, BRX, C03, C04, F31, F34 DOR, GOX, CHX, F32, F33, F36, F37</p>	<p>Comando TRATTO <i>Handle TRATTO / Griff TRATTO / Commande TRATTO / Mando TRATTO</i></p> <p>PR51MA002 PR51MA102</p> <p>CRL IX, CRB, BLX, BRX, C03, C04, F31, F34 DOR, GOX, CHX, F32, F33, F36, F37</p>	<p>Comando RIGO <i>Handle RIGO / Griff RIGO / Commande RIGO / Mando RIGO</i></p> <p>PR51MA003 PR51MA103</p> <p>CRL IX, CRB, BLX, BRX, C03, C04, F31, F34 DOR, GOX, CHX, F32, F33, F36, F37</p>	<p>Comando PUNTO <i>Handle PUNTO / Griff PUNTO / Commande PUNTO / Mando PUNTO</i></p> <p>PR51MA004 PR51MA104</p> <p>CRL IX, CRB, BLX, BRX, C03, C04, F31, F34 DOR, GOX, CHX, F32, F33, F36, F37</p>
---	---	---	--

Accessori / Accessories / Zubehör / Accessoires / Accesorios

Prolunghe / Extensions / Verlängerungen / Rallonges / Prolongadoras & Ricambi / Spare parts / Ersatzteile / Pièces de rechange / Recambios

+70mm	+120mm	+150mm	+210mm					
E0BA0190H3 pag. 1200	E0BA0190H3.5 pag. 1200	E0BA0190H4 pag. 1200	E0BA0190H5 pag. 1201	RCMB323 pag. 1219	RCMB435 pag. 1220	RCMB613 pag. 1226	RCMB617 pag. 1226	RCMBA162 pag. 1250

Miscelatore e comando venduti separatamente
Mixer and handle sold separately / Mischer und Griff separat verkauft / Mitigeur et manette vendus séparément / Mezclador y mando vendidos separatamente



Gruppo a tre fori per bidet
Three holes bidet group
Dreiloch Bidetbatterie
Groupe trois trous pour bidet
Grupo mezclador con bimando para bidet

senza comandi [PR51MB00x]
without handles [PR51MB00x]
ohne Griffe [PR51MB00x]
sans commandes [PR51MB00x]
sin mandos [PR51MB00x]





Miscelatore completo (senza comando)
Complete mixer (without handle) / Vollständige
Mischer (ohne Griff) / Mitigeur complete (sans
commande) / Mezclador completo (sin mando)

PR51BP201

CRL
IX, CRB, BLX, BRX, C03, C04, F31, F34
DOR, GOX, CHX, F32, F33, F36, F37

+ Comando / Handles / Griff / Comande / Mando

Comandi PRISMA
Handles PRISMA / Griffe PRISMA /
Commandes PRISMA / Mandos
PRISMA



PR51MB011

CRL
IX, CRB, BLX, BRX,
C03, C04, F31, F34
DOR, GOX, CHX, F32,
F33, F36, F37

Comandi TRATTO
Handles TRATTO / Griffe TRATTO
/ Commandes TRATTO / Mandos
TRATTO



PR51MB012

CRL
IX, CRB, BLX, BRX,
C03, C04, F31, F34
DOR, GOX, CHX, F32,
F33, F36, F37

Comandi RIGO
Handles RIGO / Griffe RIGO /
Commandes RIGO / Mandos
RIGO



PR51MB013

CRL
IX, CRB, BLX, BRX,
C03, C04, F31, F34
DOR, GOX, CHX, F32,
F33, F36, F37

Comandi PUNTO
Handles PUNTO / Griffe PUNTO /
Commandes PUNTO / Mandos
PUNTO



PR51MB014

CRL
IX, CRB, BLX, BRX,
C03, C04, F31, F34
DOR, GOX, CHX, F32,
F33, F36, F37

Accessori / Accessories / Zubehör / Accessoires / Accesorios

Ricambi / Spare parts / Ersatzteile / Pièces de rechange / Recambios



RCMB068 pag. 1216	RCMB307 pag. 1218	RCMB617 pag. 1226	RCMB972 pag. 1242	RCMBA069 pag. 1245	RCMBA135 pag. 1248	RCMBA149 pag. 1249	RCMBA162 pag. 1250
----------------------	----------------------	----------------------	----------------------	-----------------------	-----------------------	-----------------------	-----------------------

Miscelatore e comandi venduti separatamente
Mixer and handles sold separately / Mischer und Griffe separat verkauf / Mélangeur et manettes vendus séparément / Mezclador y mandos vendidos separatamente



Gruppo a tre fori per bidet
Three holes bidet group
Dreiloch Bidetbatterie
Groupe trois trous pour bidet
Grupo mezclador con bimando para bidet

senza comandi [PR51MB00x]
without handles [PR51MB00x]
ohne Griffe [PR51MB00x]
sans commandes [PR51MB00x]
sin mandos [PR51MB00x]





Miscelatore completo (senza comando)
Complete mixer (without handle) / Vollständige
Mischer (ohne Griff) / Mitigeur complete (sans
commande) / Mezclador completo (sin mando)

PR51BP202

CRL

IX, CRB, BLX, BRX, C03, C04, F31, F34

DOR, GOX, CHX, F32, F33, F36, F37

+ *Comando / Handles / Griff / Commande / Mando*

Comandi PRISMA
Handles PRISMA / Griffe PRISMA /
Commandes PRISMA / Mandos
PRISMA



PR51MB011

CRL

IX, CRB, BLX, BRX,
C03, C04, F31, F34

DOR, GOX, CHX, F32,
F33, F36, F37

Comandi TRATTO
Handles TRATTO / Griffe TRATTO
/ Commandes TRATTO / Mandos
TRATTO



PR51MB012

CRL

IX, CRB, BLX, BRX,
C03, C04, F31, F34

DOR, GOX, CHX, F32,
F33, F36, F37

Comandi RIGO
Handles RIGO / Griffe RIGO /
Commandes RIGO / Mandos
RIGO



PR51MB013

CRL

IX, CRB, BLX, BRX,
C03, C04, F31, F34

DOR, GOX, CHX, F32,
F33, F36, F37

Comandi PUNTO
Handles PUNTO / Griffe PUNTO /
Commandes PUNTO / Mandos
PUNTO



PR51MB014

CRL

IX, CRB, BLX, BRX,
C03, C04, F31, F34

DOR, GOX, CHX, F32,
F33, F36, F37

Accessori / Accessories / Zubehör / Accessoires / Accesorios

Ricambi / Spare parts / Ersatzteile / Pièces de rechange / Recambios



RCMB068
pag. 1216

RCMB307
pag. 1218

RCMB617
pag. 1226

RCMB972
pag. 1242

RCMBA069
pag. 1245

RCMBA135
pag. 1248

RCMBA149
pag. 1249

RCMBA162
pag. 1250

Miscelatore e comandi venduti separatamente

Mixer and handles sold separately / Mischer und Griffe separat verkauft / Mélangeur et manettes vendus séparément / Mezclador y mandos vendidos separatamente

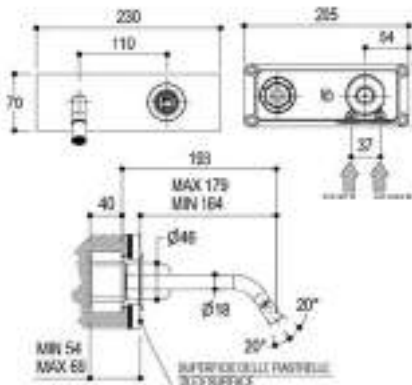
	<p>Miscelatore monocomando ad incasso per bidet <i>Built-in single lever bidet mixer</i> <i>UP-Einhandmischer für Bidet</i> <i>Mitigeur monocommande à encastrer pour bidet</i> <i>Mezclador monomando empotrado para bidet</i></p> <hr/> <p>_ canna SX Lmax=179mm _ piastra esterna _ completo di parti interne _ ohne Griff [PR51MC10x] <i>_ bica ESQ. Lmax=179mm _ Placa externa _ munido de partes internas _ without handle [PR51MC10x]</i> <i>_ Einlaufrohr L Lmax=179mm _ Montageplatte _ komplett mit UP-Teilen _ sin mando [PR51MC10x]</i> <i>_ Bec SX Lmax=179mm _ plaque externe _ complet avec parties internes _ senza comando [PR51MC10x]</i> <i>_ caño SX Lmax=179mm _ plancha externa _ completo de partes internas _ sans commande [PR51MC10x]</i></p>	
---	---	---



Parti esterne
Outer parts / Fertigset / Parties externes / Partes externas

PR51BZ101

CRL
IX, CRB, BLX, BRX, C03, C04, F31, F34
DOR, GOX, CHX, F32, F33, F36, F37



Parti da incasso
Built-in parts / UP-teile / Parties internes / Partes internas

E0BA0115SX

+ Comando / Handles / Griff / Commande / Mando

Comando PRISMA
Handle PRISMA / Griff PRISMA / Commande PRISMA / Mando PRISMA



PR51MC101

CRL
IX, CRB, BLX, BRX, C03, C04, F31, F34
DOR, GOX, CHX, F32, F33, F36, F37

Comando TRATTO
Handle TRATTO / Griff TRATTO / Commande TRATTO / Mando TRATTO



PR51MC102

CRL
IX, CRB, BLX, BRX, C03, C04, F31, F34
DOR, GOX, CHX, F32, F33, F36, F37

Comando RIGO
Handle RIGO / Griff RIGO / Commande RIGO / Mando RIGO



PR51MC103

CRL
IX, CRB, BLX, BRX, C03, C04, F31, F34
DOR, GOX, CHX, F32, F33, F36, F37

Comando PUNTO
Handle PUNTO / Griff PUNTO / Commande PUNTO / Mando PUNTO



PR51MC104

CRL
IX, CRB, BLX, BRX, C03, C04, F31, F34
DOR, GOX, CHX, F32, F33, F36, F37

Accessori / Accessories / Zubehör / Accessoires / Accesorios

Prolunghe / Extensions / Verlängerungen / Rallonges / Prolongadoras & Ricambi / Spare parts / Ersatzteile / Pièces de rechange / Recambios

+20mm	+40mm						
RCMB054H1 pag. 1202	RCMB054H2 pag. 1202	RCMB015 pag. 1213	RCMB617 pag. 1226	RCMB742 pag. 1231	RCMBA127H3 pag. 1247	RCMBA140 pag. 1249	RCMBA162 pag. 1250

Miscelatore e comando venduti separatamente
Mixer and handle sold separately / Mischer und Griff separat verkauf / Mitigeur et manette vendus séparément / Mezclador y mando vendidos separatamente



Miscelatore monocomando ad incasso per bidet
Built-in single lever bidet mixer
UP-Einhandmischer für Bidet
Mitigeur monocommande à encastrer pour bidet
Mezclador monomando empotrado para bidet

canna SX Lmax=179mm _ completo di parti interne _ ohne Griff [PR51MC10x]
bica ESQ. Lmax=179mm _ munido de partes internas _ without handle [PR51MC10x]
Einlaufrohr LI Lmax=179mm _ komplett mit UP-Teilen _ sin mando [PR51MC10x]
Bec SX Lmax=179mm _ complet avec parties internes _ senza comando [PR51MC10x]
caño SX Lmax=179mm _ completo de partes internas _ sans commande [PR51MC10x]

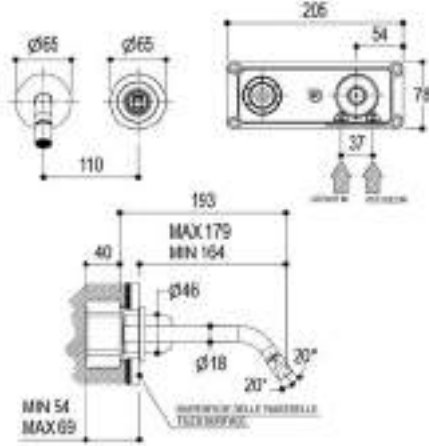





Parti esterne
Outer parts / Fertigset / Parties externes / Partes externas

PR51BZ201

CRL
IX, CRB, BLX, BRX, C03, C04, F31, F34
DOR, GOX, CHX, F32, F33, F36, F37



Parti da incasso
Built-in parts / UP-teile / Parties internes / Partes internas





E0BA0115SX

Miscelatore completo (senza comando)
Complete mixer (without handle) / Vollständige Mischer (ohne Griff) / Mitigeur complete (sans commande) / Mezclador completo (sin mando)

PR51BY201

CRL
IX, CRB, BLX, BRX, C03, C04, F31, F34
DOR, GOX, CHX, F32, F33, F36, F37

+ Comando / Handles / Griff / Commande / Mando

<p>Comando PRISMA <i>Handle PRISMA / Griff PRISMA / Commande PRISMA / Mando PRISMA</i></p>  <p>PR51MC101</p> <hr/> <p>CRL IX, CRB, BLX, BRX, C03, C04, F31, F34 DOR, GOX, CHX, F32, F33, F36, F37</p>	<p>Comando TRATTO <i>Handle TRATTO / Griff TRATTO / Commande TRATTO / Mando TRATTO</i></p>  <p>PR51MC102</p> <hr/> <p>CRL IX, CRB, BLX, BRX, C03, C04, F31, F34 DOR, GOX, CHX, F32, F33, F36, F37</p>	<p>Comando RIGO <i>Handle RIGO / Griff RIGO / Commande RIGO / Mando RIGO</i></p>  <p>PR51MC103</p> <hr/> <p>CRL IX, CRB, BLX, BRX, C03, C04, F31, F34 DOR, GOX, CHX, F32, F33, F36, F37</p>	<p>Comando PUNTO <i>Handle PUNTO / Griff PUNTO / Commande PUNTO / Mando PUNTO</i></p>  <p>PR51MC104</p> <hr/> <p>CRL IX, CRB, BLX, BRX, C03, C04, F31, F34 DOR, GOX, CHX, F32, F33, F36, F37</p>
--	--	---	---

Accessori / Accessories / Zubehör / Accessoires / Accesorios

Prolunghe / Extensions / Verlängerungen / Rallonges / Prolongadoras & Ricambi / Spare parts / Ersatzteile / Pièces de rechange / Recambios

								
+25mm	+40mm							
RCMB054H1 pag. 1202	RCMB054H2 pag. 1202	RCMB015 pag. 1213	RCMB617 pag. 1226	RCMB742 pag. 1231	RCMBA127H3 pag. 1247	RCMBA133 pag. 1248	RCMBA146 pag. 1249	RCMBA162 pag. 1250

Miscelatore e comando venduti separatamente
Mixer and handle sold separately / Mischer und Griff separat verkauft / Mitigeur et manette vendus séparément / Mezclador y mando vendidos separatamente

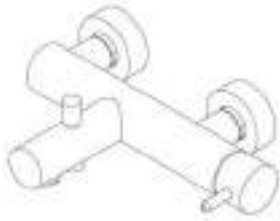

Miscelatore monocomando esterno per vasca
External single lever bath mixer
AP- Einhandmischer für Badewanne
Mitigeur monocommande externe pour baignoire
Mezclador monomando externo para bañera

_ due uscite _ deviatore automatico vasca/doccia
_ two ways _ automatic diverter bath/shower
_ Zwei Abgänge _ Automatischer Umsteller von Wanne auf Dusche
_ deux sorties _ inverseur automatique bain/douche
_ dos salidas _ desviador automático bañera/ducha

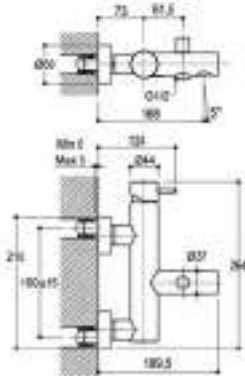

IN
1/2" M

OUT
1/2" M

Q0BA6030 CRL
IX, CRB, BLX, BRX, C03, C04, F31, F34
DOR, GOX, CHX, F32, F33, F36, F37

Accessori / Accessories / Zubehör / Accessoires / Accesorios

Ricambi / Spare parts / Ersatzteile / Pièces de rechange / Recambios

				
RCMB007H1 pag. 1213	RCMB114 pag. 1216	RCMB320 pag. 1219	RCMB321 pag. 1219	RCMB651 pag. 1228



Miscelatore monocomando esterno per vasca
External single lever bath mixer
AP- Einhandmischer für Badewanne
Mitigeur monocommande externe pour baignoire
Mezclador monomando externo para bañera

_ due uscite _ deviatore automatico vasca/doccia _ doccetta Ø24mm in ottone con flessibile da 1500mm _ getto fisso
_ two ways _ automatic diverter bath/shower _ brass Ø24mm hand shower with 1500mm flexible hose _ fixed jet
_ zwei Abgänge _ automatische Umstellung von Wanne auf Dusche _ Handbrause Ø24mm aus messing mit Schlauch 1500mm _ feststehender Strahl
_ deux sorties _ inverseur automatique bain/douche _ douchette Ø24mm en laiton avec flexible de 1500mm _ jet fixe
_ dos salidas _ desviador automático bañera/ducha _ ducha teléfono Ø24mm en latón con flexible de 1500mm _ chorro fijo

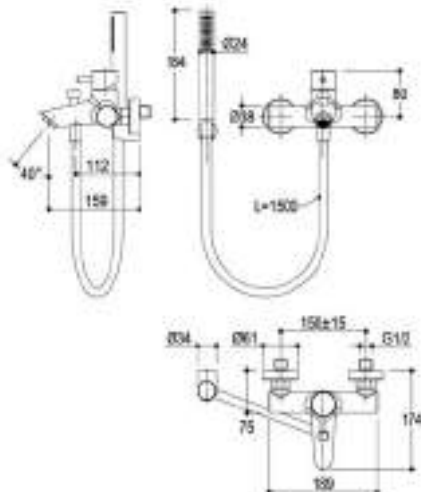

IN
1/2" M

Q0BA6032 CRL

Accessori / Accessories / Zubehör / Accessoires / Accesorios

Ricambi / Spare parts / Ersatzteile / Pièces de rechange / Recambios

			
RCMB320 pag. 1219	RCMB321 pag. 1219	RCMB566 pag. 1223	RCMB567 pag. 1224



Miscelatore monocomando ad incasso per vasca
Built-in single lever bath mixer
Einhandmischer für Badewanne
Mitigeur monocommande à encastrer pour baignoire
Mezclador monomando empotrado para bañera

due/tre uscite con deviatore rotativo _ bocca di erogazione L=200mm _ piastra esterna _ doccetta Ø24mm in ottone con flessibile da 1500mm _ completo di parti interne
due/tre uscite con deviatore rotativo _ bocca di erogazione L=200mm _ piastra esterna _ completo di parti interne _ senza comando [PR51MC10x]
two/three ways with rotative diverter _ spout L=200mm _ external plate _ Ø24mm brass hand shower without 1500mm flexible hose _ complete of inner parts
zwei/drei Abgänge mit Drehumsteller _ Wandauslauf L=200mm _ Montageplatte _ Handbrause Ø24mm aus messing _ komplett mit UP-Teilen
deux/trois sorties avec inverseur rotatif _ bec verseur L=200mm _ plaque exterieure _ douche téléphone Ø24mm en laiton avec flexible de 1500mm _ complet avec parties internes _ sans commande [PR51MC10x]
dos/tres salidas con mando desviador giratorio _ caño L=200mm _ plancha externa _ ducha teléfono Ø24mm en latón con flexible de 1500mm _ completo de partes internas _ sin mando [PR51MC10x]

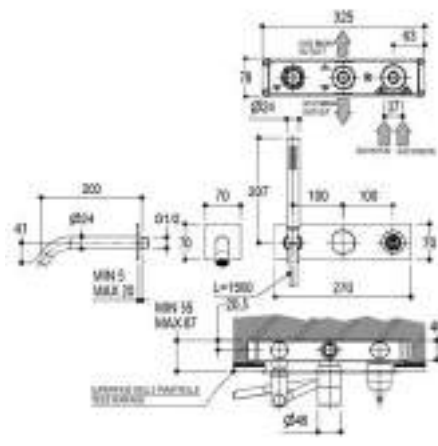





Parti esterne
Outer parts / Fertigset / Parties externes / Partes externas

PR51EN101 **CRL**
IX, CRB, BLX, BRX, C03, C04, F31, F34
DOR, GOX, CHX, F32, F33, F36, F37







Parti da incasso
Built-in parts / UP-teile / Parties internes / Partes internas

PM0020L

Miscelatore completo (senza comando)
Complete mixer (without handle) / Vollständige Mischer (ohne Griff) / Mitigeur complete (sans commande) / Mezclador completo (sin mando)

PR51EM101 **CRL**
IX, CRB, BLX, BRX, C03, C04, F31, F34
DOR, GOX, CHX, F32, F33, F36, F37

+ Comando / Handles / Griff / Commande / Mando

<p>Comando PRISMA <i>Handle PRISMA / Griff PRISMA / Commande PRISMA / Mando PRISMA</i></p>  <p>PR51MC101</p> <hr/> <p>CRL IX, CRB, BLX, BRX, C03, C04, F31, F34 DOR, GOX, CHX, F32, F33, F36, F37</p>	<p>Comando TRATTO <i>Handle TRATTO / Griff TRATTO / Commande TRATTO / Mando TRATTO</i></p>  <p>PR51MC102</p> <hr/> <p>CRL IX, CRB, BLX, BRX, C03, C04, F31, F34 DOR, GOX, CHX, F32, F33, F36, F37</p>	<p>Comando RIGO <i>Handle RIGO / Griff RIGO / Commande RIGO / Mando RIGO</i></p>  <p>PR51MC103</p> <hr/> <p>CRL IX, CRB, BLX, BRX, C03, C04, F31, F34 DOR, GOX, CHX, F32, F33, F36, F37</p>	<p>Comando PUNTO <i>Handle PUNTO / Griff PUNTO / Commande PUNTO / Mando PUNTO</i></p>  <p>PR51MC104</p> <hr/> <p>CRL IX, CRB, BLX, BRX, C03, C04, F31, F34 DOR, GOX, CHX, F32, F33, F36, F37</p>
--	--	---	---

Accessori / Accessories / Zubehör / Accessoires / Accesorios

Ricambi / Spare parts / Ersatzteile / Pièces de rechange / Recambios

								
RCMB015 pag. 1213	RCMB552 pag. 1223	RCMB740 pag. 1231	RCMB742 pag. 1231	RCMB877 pag. 1237	RCMB954 pag. 1241	RCMBA129 pag. 1248	RCMBA137 pag. 1248	RCMBA139 pag. 1249

Miscelatore e comando venduti separatamente
Mixer and handle sold separately / Mischer und Griff separat verkauf / Mitigeur et manette vendus séparément / Mezclador y mando vendidos separatamente

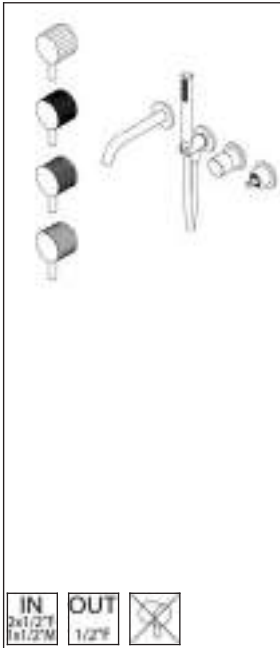

Miscelatore monocomando ad incasso per vasca

Built-in single lever bath mixer
 Einhandmischer für Badewanne
 Mitigeur monocommande à encastrer pour baignoire
 Mezclador monomando empotrado para bañera

due/tre uscite con deviatore rotativo _ bocca di erogazione L=200mm _ doccetta Ø24mm in ottone con flessibile da 1500mm _ senza piastra esterna _ completo di parti interne
 _ due/tre uscite con deviatore rotativo _ bocca di erogazione L=200mm _ doccetta Ø24mm in ottone con flessibile da 1500mm _ senza piastra esterna _ completo di parti interne _ senza comando [PR51MC10x]

two/three ways with rotative diverter _ spout L=200mm _ Ø24mm brass hand shower with 1500mm flexible _ without external plate _ complete of inner parts
 _ two/three ways with rotative diverter _ spout L=200mm _ brass Ø24mm hand shower with 1500mm flexible _ without external plate _ complete of inner parts _ without handle [PR51MC10x]
 zwei/drei Abgänge mit Drehumsteller _ Wandauslauf L=200mm _ Handbrause Ø24mm aus messing mit Schlauch 1500mm _ Ohne Montageplatte _ komplett mit UP-Teilenelementer Mischer _ zwei/drei Abgänge mit Drehumsteller _ Wandauslauf L=200mm _ Handbrause Ø24mm aus messing mit Schlauch 1500mm _ Ohne Montageplatte _ komplett mit UP-Teilen _ ohne Griff [PR51MC10x]

deux/trois sorties avec inverseur rotatif _ bec verseur L=200mm _ douchette Ø24mm en laiton avec flexible de 1500mm _ sans plaque extérieure _ complet avec parties internes
 _ deux/trois sorties avec inverseur rotatif _ bec verseur L=200mm _ douchette Ø24mm en laiton avec flexible de 1500mm _ sans plaque extérieure _ complet avec parties internes _ sans commande [PR51MC10x]
 dos/tres salidas con mando desviador giratorio _ caño L=200mm _ ducha teléfono Ø24mm en latón con flexible de 1500mm _ sin plancha externa _ completo de partes internas
 _ dos/tres salidas con mando desviador giratorio _ caño L=200mm _ ducha teléfono Ø24mm en latón con flexible de 1500mm _ sin plancha externa _ completo de partes internas _ sin mando [PR51MC10x]

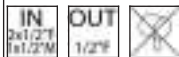
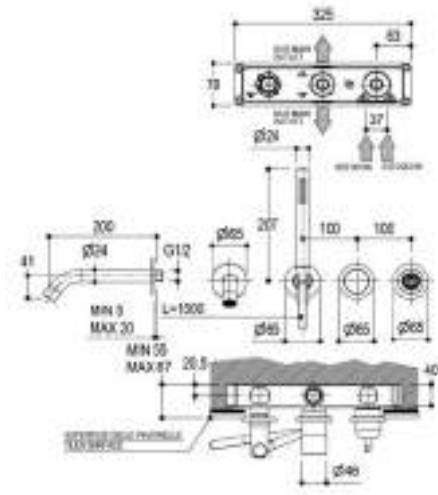

Parti esterne

Outer parts / Fertigset / Parties externes / Partes externas

PR51EN201

CRL

IX, CRB, BLX, BRX, C03, C04, F31, F34
 DOR, GOX, CHX, F32, F33, F36, F37

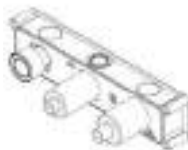

Parti da incasso

Built-in parts / UP-teile / Parties internes / Partes internas

PM0020L

Miscelatore completo (senza comando)

Complete mixer (without handle) / Vollständige Mischer (ohne Griff) / Mitigeur complete (sans commande) / Mezclador completo (sin mando)

PR51EM201

CRL

IX, CRB, BLX, BRX, C03, C04, F31, F34
 DOR, GOX, CHX, F32, F33, F36, F37

Comando / Handles / Griff / Commande / Mando

Comando PRISMA

Handle PRISMA / Griff PRISMA /
 Commande PRISMA / Mando PRISMA



PR51MC101

CRL

IX, CRB, BLX, BRX,
 C03, C04, F31, F34

DOR, GOX, CHX, F32,
 F33, F36, F37

Comando TRATTO

Handle TRATTO / Griff TRATTO /
 Commande TRATTO / Mando TRATTO



PR51MC102

CRL

IX, CRB, BLX, BRX,
 C03, C04, F31, F34

DOR, GOX, CHX, F32,
 F33, F36, F37

Comando RIGO

Handle RIGO / Griff RIGO /
 Commande RIGO / Mando RIGO



PR51MC103

CRL

IX, CRB, BLX, BRX,
 C03, C04, F31, F34

DOR, GOX, CHX, F32,
 F33, F36, F37

Comando PUNTO

Handle PUNTO / Griff PUNTO /
 Commande PUNTO / Mando PUNTO



PR51MC104

CRL

IX, CRB, BLX, BRX,
 C03, C04, F31, F34

DOR, GOX, CHX, F32,
 F33, F36, F37

Accessori / Accessories / Zubehör / Accessoires / Accesorios

Ricambi / Spare parts / Ersatzteile / Pièces de rechange / Recambios



RCMB015
 pag. 1213



RCMB552
 pag. 1223



RCMB740
 pag. 1231



RCMB742
 pag. 1231



RCMB877
 pag. 1237



RCMB954
 pag. 1241



RCMB129
 pag. 1248



RCMB146
 pag. 1249



RCMB158
 pag. 1250

Miscelatore e comando venduti separatamente

Mixer and handle sold separately / Mischer und Griff separat verkauf / Mitigeur et manette vendus séparément / Mezclador y mando vendidos separatamente

Gruppo per bordo vasca
Deck mounted bath group
Wannerandbatterie
Batterie sur gorge pour baignoire
Grupo para borde bañera

_ miscelatore monocomando a due uscite con deviatore automatico bocca di erogazione/doccetta _ canna quadra H=140mm L=150mm _ doccetta Ø24mm in ottone con flessibile da 1800mm _ piastra esterna _ senza comando [PR51MC10x]
_ single lever mixer with two outlets with automatic diverter square spout/hand shower _ square spout H=140mm L=150mm _ Ø24mm brass hand shower with 1800mm flexible hose _ external plate _ without handle [PR51MC10x]
_ zwei Abgänge Einhandmischer mit automatischem Umsteller Auslauf/Brause _ Quadratischer Wandauslauf H=140mm L=150mm _ Handbrause Ø24mm aus messing mit Schlauch 1800mm _ Montageplatte _ ohne Griff [PR51MC10x]
_ deux sorties mitigeur monocommande avec inverseur automatique bec/douchette _ bec carré H=140mm L=150mm _ douchette Ø24mm en laiton avec flexible de 1800mm _ plaque extérieure _ sans commande [PR51MC10x]
_ mezclador monomando dos salidas con desviador automático caño/duchita _ caño cuadrado H=140mm L=150mm _ ducha teléfono Ø24mm en latón con flexible de 1800mm _ plancha externa _ sin mando [PR51MC10x]

<p>Miscelatore completo (senza comando) <i>Complete mixer (without handle) / Vollständige Mischer (ohne Griff) / Mitigeur complete (sans commande) / Mezclador completo (sin mando)</i></p>	<p>PR51ES101</p>	<p>CRL IX, CRB, BLX, BRX, C03, C04, F31, F34 DOR, GOX, CHX, F32, F33, F36, F37</p>
---	-------------------------	---

+ Comando / Handles / Griff / Commande / Mando

<p>Comando PRISMA <i>Handle PRISMA / Griff PRISMA / Commande PRISMA / Mando PRISMA</i></p> <p>PR51MC101</p> <hr/> <p>CRL IX, CRB, BLX, BRX, C03, C04, F31, F34 DOR, GOX, CHX, F32, F33, F36, F37</p>	<p>Comando TRATTO <i>Handle TRATTO / Griff TRATTO / Commande TRATTO / Mando TRATTO</i></p> <p>PR51MC102</p> <hr/> <p>CRL IX, CRB, BLX, BRX, C03, C04, F31, F34 DOR, GOX, CHX, F32, F33, F36, F37</p>	<p>Comando RIGO <i>Handle RIGO / Griff RIGO / Commande RIGO / Mando RIGO</i></p> <p>PR51MC103</p> <hr/> <p>CRL IX, CRB, BLX, BRX, C03, C04, F31, F34 DOR, GOX, CHX, F32, F33, F36, F37</p>	<p>Comando PUNTO <i>Handle PUNTO / Griff PUNTO / Commande PUNTO / Mando PUNTO</i></p> <p>PR51MC104</p> <hr/> <p>CRL IX, CRB, BLX, BRX, C03, C04, F31, F34 DOR, GOX, CHX, F32, F33, F36, F37</p>
--	--	--	---

Accessori / Accessories / Zubehör / Accessoires / Accesorios

Ricambi / Spare parts / Ersatzteile / Pièces de rechange / Recambios

RCMB015 pag. 1213	RCMB021 pag. 1214	RCMB031 pag. 1214	RCMB113 pag. 1216	RCMB125 pag. 1217	RCMB221 pag. 1218	RCMB443 pag. 1220	RCMB552 pag. 1223	RCMB742 pag. 1231	RCMBA128 pag. 1248

Miscelatore e comando venduti separatamente - Da completare con rivestimenti che consentano l'ispezione
Mixer and handle sold separately - Make the inspection possible / Mischer und Griff separat verkauft - Inspektion ist notwendig / Mitigeur et manette vendus séparément - Permettre l'inspection / Mezclador y mando vendidos separatamente - Completar con revestimientos que permitan la inspección

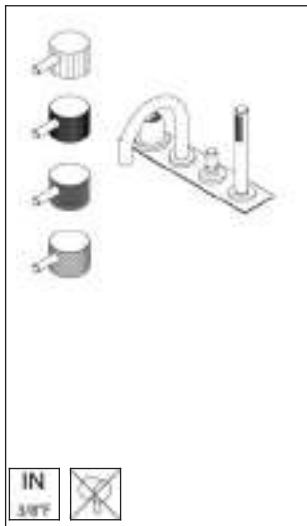

Gruppo per bordo vasca
 Deck mounted bath group
 Wannerandbatterie
 Batterie sur gorge pour baignoire
 Grupo para borde bañera

_ miscelatore monocomando a due uscite con deviatore automatico
bocca di erogazione/doccetta _ canna cigno H=175mm L=150mm _
doccetta Ø24mm in ottone con flessibile da 1800mm _ piastra
esterna _ senza comando [PR51MC10x]
 _ single lever mixer with two outlets with automatic diverter spout/hand
 shower _ spout H=175mm L=150mm _ Ø24mm brass hand shower with
 1800mm flexible hose _ external plate _ without handle [PR51MC10x]
 _ zwei Abgänge Einhandmischer mit automatischem Umsteller
 Auslauf/Brause _ Schwänen Auslauf H=175mm L=150mm _ Handbrause
 Ø24mm aus messing mit Schlauch 1800mm _ Montageplatte _ ohne Griff
 [PR51MC10x]
 _ deux sorties mitigeur monocommande avec inverseur automatique
 bec/douchette _ bec col de cygne H=175mm L=150mm _ douchette
 Ø24mm en laiton avec flexible de 1800mm _ plaque extérieure _ sans
 commande [PR51MC10x]
 _ mezclador monocomando dos salidas con desviador automático
 caño/duchita _ caño cisne H=175mm L=150mm _ ducha teléfono Ø24mm
 en latón con flexible de 1800mm _ plancha externa _ sin mando
 [PR51MC10x]

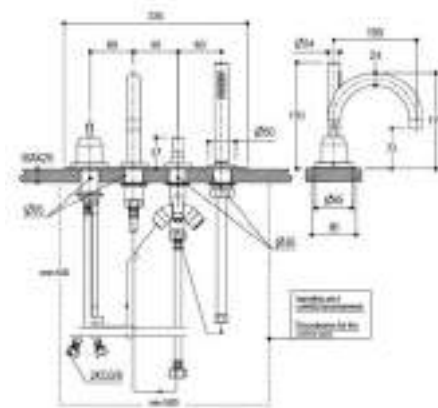

Miscelatore completo (senza comando)
 Complete mixer (without handle) / Vollständige
 Mischer (ohne Griff) / Mitigeur complete (sans
 commande) / Mezclador completo (sin mando)

PR51ES102

CRL
IX, CRB, BLX, BRX, C03, C04, F31, F34
DOR, GOX, CHX, F32, F33, F36, F37

+ Comando / Handles / Griff / Commande / Mando

Comando PRISMA
 Handle PRISMA / Griff PRISMA /
 Commande PRISMA / Mando
 PRISMA



PR51MC101

CRL
IX, CRB, BLX, BRX,
C03, C04, F31, F34
DOR, GOX, CHX, F32,
F33, F36, F37

Comando TRATTO
 Handle TRATTO / Griff TRATTO /
 Commande TRATTO / Mando
 TRATTO



PR51MC102

CRL
IX, CRB, BLX, BRX,
C03, C04, F31, F34
DOR, GOX, CHX, F32,
F33, F36, F37

Comando RIGO
 Handle RIGO / Griff RIGO /
 Commande RIGO / Mando RIGO



PR51MC103

CRL
IX, CRB, BLX, BRX,
C03, C04, F31, F34
DOR, GOX, CHX, F32,
F33, F36, F37

Comando PUNTO
 Handle PUNTO / Griff PUNTO /
 Commande PUNTO / Mando
 PUNTO



PR51MC104

CRL
IX, CRB, BLX, BRX,
C03, C04, F31, F34
DOR, GOX, CHX, F32,
F33, F36, F37

Accessori / Accessories / Zubehör / Accessoires / Accesorios

Ricambi / Spare parts / Ersatzteile / Pièces de rechange / Recambios



RCMB015
 pag. 1213



RCMB021
 pag. 1214



RCMB031
 pag. 1214



RCMB113
 pag. 1216



RCMB125
 pag. 1217



RCMB443
 pag. 1220



RCMB552
 pag. 1223



RCMB742
 pag. 1231



RCMB128
 pag. 1248

Miscelatore e comando venduti separatamente - Da completare con rivestimenti che consentano l'ispezione

Mixer and handle sold separately - Make the inspection possible / Mischer und Griff separat verkauft - Inspektion ist notwendig / Mitigeur et manette vendus séparément - Permettre l'inspection / Mezclador y mando vendidos separatamente - Completar con revestimientos que permitan la inspección



Gruppo per bordo vasca
Deck mounted bath group
Wannerandbatterie
Batterie sur gorge pour baignoire
Grupo para borde bañera



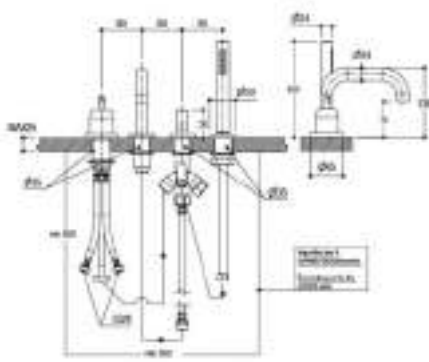

_ miscelatore monocomando a due uscite con deviatore automatico
bocca di erogazione/doccetta _ canna quadra H=138mm L=150mm _
doccetta Ø24mm in ottone con flessibile da 1800mm _ senza
comando [PR51MC10x]
 _ single lever mixer with two outlets with automatic diverter square
 spout/hand shower _ square spout H=138mm L=150mm _ Ø24mm brass
 hand shower with 1800mm flexible hose _ without handle [PR51MC10x]
 _ zwei Abgänge Einhandmischer mit automatischem Umsteller
 Auslauf/Brause _ Quadratischer Wandauslauf H=138mm L=150mm
 Handbrause Ø24mm aus messing mit Schlauch 1800mm _ ohne Griff
 [PR51MC10x]
 _ deux sorties mitigeur monocommande avec inverseur automatique
 bec/douchette _ bec carré H=138mm L=150mm _ douchette Ø24mm en
 laiton avec flexible de 1800mm _ sans commandé [PR51MC10x]
 _ mezclador monomando dos salidas con desviador automático
 caño/duchita _ caño cuadrado H=138mm L=150mm _ ducha teléfono
 Ø24mm en latón con flexible de 1800mm _ sin mando [PR51MC10x]













<p>Miscelatore completo (senza comando) <i>Complete mixer (without handle) / Vollständige</i> <i>Mischer (ohne Griff) / Mitigeur complete (sans</i> <i>commande) / Mezclador completo (sin mando)</i></p>	<p>PR51ES201</p>	<p>CRL IX, CRB, BLX, BRX, C03, C04, F31, F34 DOR, GOX, CHX, F32, F33, F36, F37</p>
---	-------------------------	---

+ Comando / Handles / Griff / Commande / Mando

<p>Comando PRISMA <i>Handle PRISMA / Griff PRISMA /</i> <i>Commande PRISMA / Mando</i> <i>PRISMA</i></p>  <p>PR51MC101</p> <hr/> <p>CRL IX, CRB, BLX, BRX, C03, C04, F31, F34 DOR, GOX, CHX, F32, F33, F36, F37</p>	<p>Comando TRATTO <i>Handle TRATTO / Griff TRATTO /</i> <i>Commande TRATTO / Mando</i> <i>TRATTO</i></p>  <p>PR51MC102</p> <hr/> <p>CRL IX, CRB, BLX, BRX, C03, C04, F31, F34 DOR, GOX, CHX, F32, F33, F36, F37</p>	<p>Comando RIGO <i>Handle RIGO / Griff RIGO /</i> <i>Commande RIGO / Mando RIGO</i></p>  <p>PR51MC103</p> <hr/> <p>CRL IX, CRB, BLX, BRX, C03, C04, F31, F34 DOR, GOX, CHX, F32, F33, F36, F37</p>	<p>Comando PUNTO <i>Handle PUNTO / Griff PUNTO /</i> <i>Commande PUNTO / Mando</i> <i>PUNTO</i></p>  <p>PR51MC104</p> <hr/> <p>CRL IX, CRB, BLX, BRX, C03, C04, F31, F34 DOR, GOX, CHX, F32, F33, F36, F37</p>
---	---	--	--

Accessori / Accessories / Zubehör / Accessoires / Accesorios

Ricambi / Spare parts / Ersatzteile / Pièces de rechange / Recambios

									
RCMB015 pag. 1213	RCMB021 pag. 1214	RCMB031 pag. 1214	RCMB113 pag. 1216	RCMB125 pag. 1217	RCMB221 pag. 1218	RCMB443 pag. 1220	RCMB552 pag. 1223	RCMB742 pag. 1231	RCMBA128 pag. 1248

Miscelatore e comando venduti separatamente - Da completare con rivestimenti che consentano l'ispezione
Mixer and handle sold separately - Make the inspection possible / Mischer und Griff separat verkauft - Inspektion ist notwendig / Mitigeur et manette vendus séparément - Permettre l'inspection
/ Mezclador y mando vendidos separatamente - Completar con revestimientos que permitan la inspección



Gruppo per bordo vasca
 Deck mounted bath group
 Wannerandbatterie
 Batterie sur gorge pour baignoire
 Grupo para borde bañera

_ miscelatore monocomando a due uscite con deviatore automatico bocca di erogazione/doccetta _ canna cigno H=173mm L=150mm _ doccetta Ø24mm in ottone con flessibile da 1800mm _ senza comando [PR51MC10x]
 _ single lever mixer with two outlets with automatic diverter spout/hand shower _ spout H=173mm L=150mm _ Ø24mm brass hand shower with 1800mm flexible hose _ without handle [PR51MC10x]
 _ zwei Abgänge Einhandmischer mit automatischem Umsteller Auslauf/Brause _ Schwänen Auslauf H=173mm L=150mm _ Handbrause Ø24mm aus messing mit Schlauch 1800mm _ ohne Griff [PR51MC10x]
 _ deux sorties mitigeur monocommande avec inverseur automatique bec/douchette _ bec col de cygne H=173mm L=150mm _ douchette Ø24mm en laiton avec flexible de 1800mm _ sans commande [PR51MC10x]
 _ mezclador monocomando dos salidas con desviador automatico caño/duchita _ caño cisne H=173mm L=150mm _ ducha teléfono Ø24mm en latón con flexible de 1800mm _ sin mando [PR51MC10x]

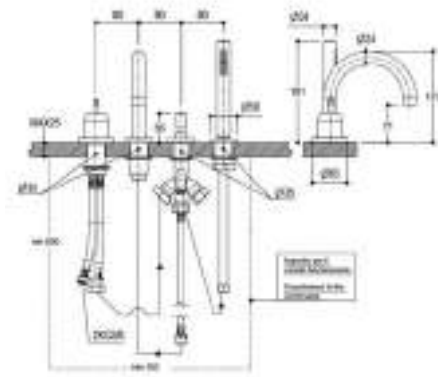

Miscelatore completo (senza comando)
 Complete mixer (without handle) / Vollständige Mischer (ohne Griff) / Mitigeur complete (sans commande) / Mezclador completo (sin mando)

PR51ES202

CRL
IX, CRB, BLX, BRX, C03, C04, F31, F34
DOR, GOX, CHX, F32, F33, F36, F37

+ Comando / Handles / Griff / Comande / Mando

Comando PRISMA
 Handle PRISMA / Griff PRISMA / Comande PRISMA / Mando PRISMA



PR51MC101

CRL
IX, CRB, BLX, BRX, C03, C04, F31, F34
DOR, GOX, CHX, F32, F33, F36, F37

Comando TRATTO
 Handle TRATTO / Griff TRATTO / Comande TRATTO / Mando TRATTO



PR51MC102

CRL
IX, CRB, BLX, BRX, C03, C04, F31, F34
DOR, GOX, CHX, F32, F33, F36, F37

Comando RIGO
 Handle RIGO / Griff RIGO / Comande RIGO / Mando RIGO



PR51MC103

CRL
IX, CRB, BLX, BRX, C03, C04, F31, F34
DOR, GOX, CHX, F32, F33, F36, F37

Comando PUNTO
 Handle PUNTO / Griff PUNTO / Comande PUNTO / Mando PUNTO



PR51MC104

CRL
IX, CRB, BLX, BRX, C03, C04, F31, F34
DOR, GOX, CHX, F32, F33, F36, F37

Accessori / Accessories / Zubehör / Accessoires / Accesorios

Ricambi / Spare parts / Ersatzteile / Pièces de rechange / Recambios



RCMB015
 pag. 1213



RCMB021
 pag. 1214



RCMB031
 pag. 1214



RCMB113
 pag. 1216



RCMB125
 pag. 1217



RCMB443
 pag. 1220



RCMB552
 pag. 1223



RCMB742
 pag. 1231



RCMB128
 pag. 1248

Miscelatore e comando venduti separatamente - Da completare con rivestimenti che consentano l'ispezione

Mixer and handle sold separately - Make the inspection possible / Mischer und Griff separat verkauft - Inspektion ist notwendig / Mitigeur et manette vendus séparément - Permettre l'inspection / Mezclador y mando vendidos separatamente - Completar con revestimientos que permitan la inspección



Deviatore automatico per gruppo bordo vasca
Automatic diverter for deck mounted bath group
Automatischer Umsteller für Wannerandbatterie
Inverseur automatique pour batterie sur gorge
Desviador automático para grupo borde bañera

_ **completo di parti estetiche e kit di fissaggio**
 _ complete of finish set and fixing kit
 _ mit Fertigset und Komponenten für Fixierung
 _ complet de kit de finition et de fixation
 _ completo de partes estéticas y kit de fijación





7ALF201 **CRL**

IX, CRB, BLX, BRX, C03, C04, F31, F34

DOR, GOX, CHX, F32, F33, F36, F37

Accessori / Accessories / Zubehör / Accessoires / Accesorios

Ricambi / Spare parts / Ersatzteile / Pièces de rechange / Recambios



RCMB113
pag. 1216



RCMB216
pag. 1218



RCMB416
pag. 1220



RCMB4128
pag. 1248

Da completare con rivestimenti che consentano l'ispezione
Make the inspection possible / Inspektion ist notwendig / Permettre l'inspection / Completar con revestimientos que permitan la inspección



Supporto doccetta per bordovasca con doccetta e flessibile
Hand shower support for deck mounted bath group with hand shower and flexible
Schlauchdurchführung mit Handbrause und Brauseschlauch
Support pour douchette batterie sur gorge avec douchette et flexible
Soporte duchita para grupo borde bañera con ducha y flexible

_ **doccetta Ø24mm in ottone _ flessibile tre strati, rinforzo tessile e sottostrato metallizzato _ L=1800mm**
 _ Ø24mm brass hand shower _ three layers flexible, reinforced with metalized Nylon yarn _ L=1800mm
 _ Handbrause aus messing Ø24mm _ Brauseschlauch dreischichtig, Verstärkung mit metallisiertem Nylon _ L=1800mm
 _ douchette en laiton Ø24mm _ flexible trois couches, renforcé par Nylon et métallisé _ L=1800mm
 _ ducha teléfono en latón Ø24mm _ flexible tres estratos, reforzado con Nylon metalizado _ L=1800mm





72U013 **CRL**

IX, CRB, BLX, BRX, C03, C04, F31, F34

DOR, GOX, CHX, F32, F33, F36, F37

Accessori / Accessories / Zubehör / Accessoires / Accesorios

Ricambi / Spare parts / Ersatzteile / Pièces de rechange / Recambios



RCMB031
pag. 1214



RCMB443
pag. 1220

Da completare con rivestimenti che consentano l'ispezione. Solo nelle finiture CRL/CRB/BLX/C03/C04/IX disponibile con doccetta in ABS Ø26mm.
Make the inspection possible. Available with Ø26mm ABS hand shower for CRL/CRB/BLX/C03/C04/IX finishings only. / Inspektion ist notwendig. Lieferbar mit Handbrause aus ABS Ø26mm nur für Oberflächen CRL/CRB/BLX/C03/C04/IX. / Permettre l'inspection. Disponible avec douchette en ABS Ø26mm uniquement pour Finitions CRL/CRB/BLX/C03/C04/IX. / Completar con revestimientos que permitan la inspección. Disponible con ducha teléfono Ø26mm en ABS solo para acabados CRL/CRB/BLX/C03/C04/IX.

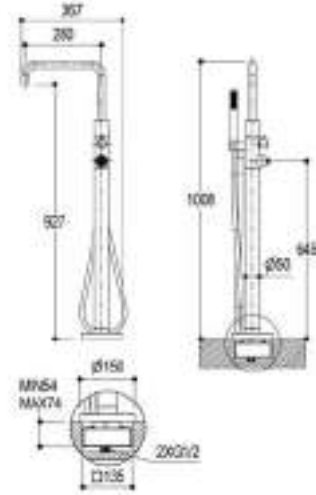
	<p>Colonna bordo vasca da terra <i>Standing floor bath group</i> <i>Bodenstand-Wannebatterie</i> <i>Colonne baignoire au sol</i> <i>Grupo para borde bañera</i></p> <hr/> <p>due uscite con deviatore doccetta/bocca di erogazione quadra doccetta ottone Ø24 con flessibile da 1.500mm _ completo di parti interne _ senza comando [PR51ML10x] <i>two ways single lever with diverter hand shower/square spout</i> _ brass Ø24 hand shower with 1.500mm flexible hose _ with inner parts _ without handle [PR51ML10x] <i>zwei Abgänge Umstellung</i> _ Quadratischer Auslauf _ Handbrause aus messing Ø24 mit Schlauch 1.500mm _ mit UP-Teilen _ ohne Griff [PR51ML10x] <i>deux sorties, inverseur pour bec carré/douchette</i> _ douchette en laiton Ø24 avec flexible de 1.500mm _ complet avec parties internes _ sans commande [PR51ML10x] <i>dos salidas y desviador boca de erogación cuadrada/duchita</i> _ ducha teléfono en latón Ø24 con flexible de 1.500mm _ completo de partes internas _ sin mando [PR51ML10x]</p>	
---	---	---





	<p>Parti esterne <i>Outer parts / Fertigset / Parties externes / Partes externas</i></p>	<p>PR51DE201 CRL IX, CRB, BLX, BRX, C03, C04, F31, F34 DOR, GOX, CHX, F32, F33, F36, F37</p>
---	--	--

	<p>Parti da incasso <i>Built-in parts / UP-teile / Parties internes / Partes internas</i></p>	<p>PM00801</p>
--	---	-----------------------

<p>Miscelatore completo (senza comando) <i>Complete mixer (without handle) / Vollständige Mischer (ohne Griff) / Mitigeur complete (sans commande) / Mezclador completo (sin mando)</i></p>	<p>PR51DD201 CRL IX, CRB, BLX, BRX, C03, C04, F31, F34 DOR, GOX, CHX, F32, F33, F36, F37</p>
---	--

+ Comando / Handles / Griff / Commande / Mando

<p>Comando PRISMA <i>Handle PRISMA / Griff PRISMA / Commande PRISMA / Mando PRISMA</i></p>  <p>PR51ML101</p> <p>CRL IX, CRB, BLX, BRX, C03, C04, F31, F34 DOR, GOX, CHX, F32, F33, F36, F37</p>	<p>Comando TRATTO <i>Handle TRATTO / Griff TRATTO / Commande TRATTO / Mando TRATTO</i></p>  <p>PR51ML102</p> <p>CRL IX, CRB, BLX, BRX, C03, C04, F31, F34 DOR, GOX, CHX, F32, F33, F36, F37</p>	<p>Comando RIGO <i>Handle RIGO / Griff RIGO / Commande RIGO / Mando RIGO</i></p>  <p>PR51ML103</p> <p>CRL IX, CRB, BLX, BRX, C03, C04, F31, F34 DOR, GOX, CHX, F32, F33, F36, F37</p>	<p>Comando PUNTO <i>Handle PUNTO / Griff PUNTO / Commande PUNTO / Mando PUNTO</i></p>  <p>PR51ML104</p> <p>CRL IX, CRB, BLX, BRX, C03, C04, F31, F34 DOR, GOX, CHX, F32, F33, F36, F37</p>
--	--	--	---

Accessori / Accessories / Zubehör / Accessoires / Accesorios

Ricambi / Spare parts / Ersatzteile / Pièces de rechange / Recambios

 <p>RCMB007 pag. 1213</p>	 <p>RCMB552 pag. 1223</p>	 <p>RCMB663 pag. 1228</p>	 <p>RCMB665 pag. 1229</p>	 <p>RCMB806 pag. 1233</p>	 <p>RCMBA160 pag. 1250</p>	 <p>RCMBA161 pag. 1250</p>	 <p>RCMBA168 pag. 1251</p>
--	--	--	--	--	---	---	---



Miscelatore e comando venduti separatamente
Mixer and handle sold separately / Mischer und Griff separat verkauf / Mitigeur et manette vendus séparément / Mezclador y mando vendidos separatamente

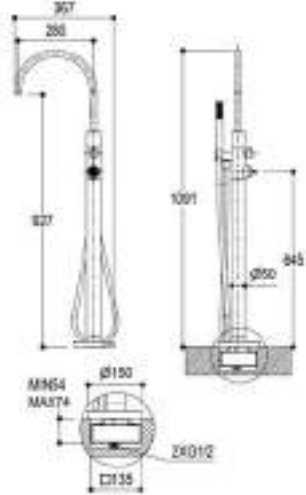

Colonna bordo vasca da terra
Standing floor bath group
Bodenstand-Wannebatterie
Colonne baignoire au sol
Grupo para borde bañera

_ due uscite con deviatore doccia/bocca di erogazione quadra _
doccetta ottone Ø24 con flessibile da 1.500mm _ completo di parti interne _ senza comando [PR51ML10x]
_ two ways single lever with diverter hand shower/square spout _ brass Ø24 hand shower with 1.500mm flexible hose _ with inner parts _ without handle [PR51ML10x]
_ zwei Abgänge Umstellung _ Quadratischer Auslauf _ Handbrause aus messing Ø24 mit Schlauch 1.500mm _ mit UP-Teilen _ ohne Griff [PR51ML10x]
_ deux sorties, inverseur pour bec carré/douchette _ douchette en laiton Ø24 avec flexible de 1.500mm _ complet avec parties internes _ sans commande [PR51ML10x]
_ dos salidas y desviador boca de erogación cuadrada/duchita _ ducha teléfono en latón Ø24 con flexible de 1.500mm _ completo de partes internas _ sin mando [PR51ML10x]





Parti esterne
Outer parts / Fertigset / Parties externes / Partes externas

PR51DE202 **CRL**
IX, CRB, BLX, BRX, C03, C04, F31, F34
DOR, GOX, CHX, F32, F33, F36, F37



Parti da incasso
Built-in parts / UP-teile / Parties internes / Partes internas

PM00801

Miscelatore completo (senza comando)
Complete mixer (without handle) / Vollständige Mischer (ohne Griff) / Mitigeur complete (sans commande) / Mezclador completo (sin mando)

PR51DD202 **CRL**
IX, CRB, BLX, BRX, C03, C04, F31, F34
DOR, GOX, CHX, F32, F33, F36, F37

+ Comando / Handles / Griff / Commande / Mando

Comando PRISMA
Handle PRISMA / Griff PRISMA / Commande PRISMA / Mando PRISMA



PR51ML101

CRL	€ 99,0
IX, CRB, BLX, BRX, C03, C04, F31, F34	€ 144,0
DOR, GOX, CHX, F32, F33, F36, F37	€ 198,0

Comando TRATTO
Handle TRATTO / Griff TRATTO / Commande TRATTO / Mando TRATTO



PR51ML102

CRL	€ 99,0
IX, CRB, BLX, BRX, C03, C04, F31, F34	€ 144,0
DOR, GOX, CHX, F32, F33, F36, F37	€ 198,0

Comando RIGO
Handle RIGO / Griff RIGO / Commande RIGO / Mando RIGO



PR51ML103

CRL	€ 99,0
IX, CRB, BLX, BRX, C03, C04, F31, F34	€ 144,0
DOR, GOX, CHX, F32, F33, F36, F37	€ 198,0

Comando PUNTO
Handle PUNTO / Griff PUNTO / Commande PUNTO / Mando PUNTO



PR51ML104

CRL	€ 99,0
IX, CRB, BLX, BRX, C03, C04, F31, F34	€ 144,0
DOR, GOX, CHX, F32, F33, F36, F37	€ 198,0

Accessori / Accessories / Zubehör / Accessoires / Accesorios

Ricambi / Spare parts / Ersatzteile / Pièces de rechange / Recambios



RCMB007 pag. 1213	RCMB552 pag. 1223	RCMB663 pag. 1228	RCMB665 pag. 1229	RCMB806 pag. 1233	RCMBA160 pag. 1250	RCMBA161 pag. 1250	RCMBA168 pag. 1251
----------------------	----------------------	----------------------	----------------------	----------------------	-----------------------	-----------------------	-----------------------

Miscelatore e comando venduti separatamente
Mixer and handle sold separately / Mischer und Griff separat verkauft / Mitigeur et manette vendus séparément / Mezclador y mando vendidos separatamente



Miscelatore monocomando esterno per doccia
External single lever shower mixer
AP- Einhandmischer für Dusche
Mitigeur monocommande externe pour douche
Mezclador monomando externo para ducha

_ **una uscita**
 _ one way
 _ Ein Abgang
 _ une sortie
 _ una salida

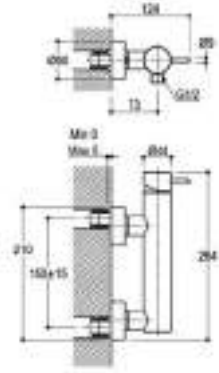

IN
1/2" M

OUT
1/2" M

Q0BA6056 **CRL**
 IX, CRB, BLX, BRX, C03, C04, F31, F34
 DOR, GOX, CHX, F32, F33, F36, F37

Accessori / Accessories / Zubehör / Accessoires / Accesorios

Ricambi / Spare parts / Ersatzteile / Pièces de rechange / Recambios



RCMB007H1
pag. 1213



RCMB320
pag. 1219



RCMB651
pag. 1228



Miscelatore monocomando esterno per doccia
Outer single lever shower mixer
AP- Einhandmischer für Dusche
Mitigeur monocommande externe pour douche
Mezclador monomando externo para ducha

_ **una uscita**
 _ one way
 _ Ein Abgang
 _ une sortie
 _ una salida

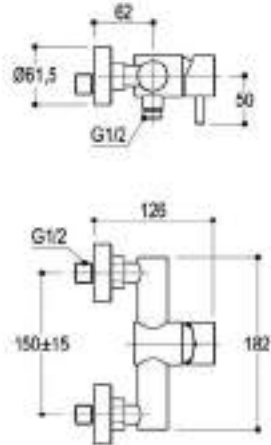

IN
1/2" M

OUT
1/2" M

Q0BA6057 **CRL**

Accessori / Accessories / Zubehör / Accessoires / Accesorios

Ricambi / Spare parts / Ersatzteile / Pièces de rechange / Recambios



RCMB320
pag. 1219



RCMB778
pag. 1232

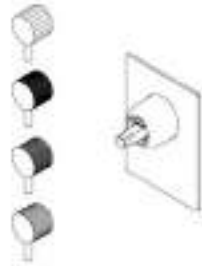

IN
1/2"

OUT
1/2"

✗

Miscelatore monocomando ad incasso per doccia/lavabo
Built-in single lever shower/basin mixer
UP-Einhandmischer für Dusche/Waschtisch
Mitigeur monocommande à encastrer pour douche/lavabo
Mezclador monomando empotrado para ducha/lavabo

_ piastra esterna _ una uscita _ completo di parti interne _ senza comando [PR51MC10x]
external plate _ one way _ complete of inner parts _ without handle [PR51MC10x]
Montageplatte _ Ein Abgang _ komplett mit UP-Teilen _ ohne Griff [PR51MC10x]
_ plaque externe _ une sortie _ complet avec parties internes _ sans commande [PR51MC10x]
_ plancha externa _ una salida _ completo de partes internas _ sin mando [PR51MC10x]

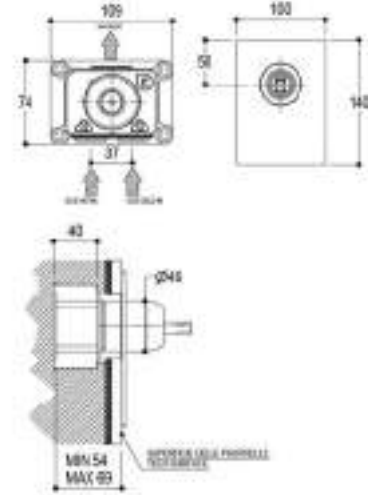



Parti esterne
Outer parts / Fertigset / Parties externes / Partes externas

PR51FN101 **CRL**
IX, CRB, BLX, BRX, C03, C04, F31, F34
DOR, GOX, CHX, F32, F33, F36, F37



Parti da incasso
Built-in parts / UP-teile / Parties internes / Partes internas

E0BA0143

Miscelatore completo (senza comando)
Complete mixer (without handle) / Vollständige Mischer (ohne Griff) / Mitigeur complete (sans commande) / Mezclador completo (sin mando)

PR51FM101 **CRL**
IX, CRB, BLX, BRX, C03, C04, F31, F34
DOR, GOX, CHX, F32, F33, F36, F37

+ Comando / Handles / Griff / Commande / Mando

Comando PRISMA
Handle PRISMA / Griff PRISMA / Commande PRISMA / Mando PRISMA



PR51MC101

CRL
IX, CRB, BLX, BRX, C03, C04, F31, F34
DOR, GOX, CHX, F32, F33, F36, F37

Comando TRATTO
Handle TRATTO / Griff TRATTO / Commande TRATTO / Mando TRATTO



PR51MC102

CRL
IX, CRB, BLX, BRX, C03, C04, F31, F34
DOR, GOX, CHX, F32, F33, F36, F37

Comando RIGO
Handle RIGO / Griff RIGO / Commande RIGO / Mando RIGO



PR51MC103

CRL
IX, CRB, BLX, BRX, C03, C04, F31, F34
DOR, GOX, CHX, F32, F33, F36, F37

Comando PUNTO
Handle PUNTO / Griff PUNTO / Commande PUNTO / Mando PUNTO



PR51MC104

CRL
IX, CRB, BLX, BRX, C03, C04, F31, F34
DOR, GOX, CHX, F32, F33, F36, F37

Accessori / Accessories / Zubehör / Accessoires / Accesorios

Prolunghe / Extensions / Verlängerungen / Rallonges / Prolongadoras & Ricambi / Spare parts / Ersatzteile / Pièces de rechange / Recambios



+25mm
RCMB054H1
pag. 1202



+40mm
RCMB054H2
pag. 1202



RCMB015
pag. 1213



RCMB742
pag. 1231



RCMBA131
pag. 1248

Miscelatore e comando venduti separatamente
Mixer and handle sold separately / Mischer und Griff separat verkauft / Mitigeur et manette vendus séparément / Mezclador y mando vendidos separatamente

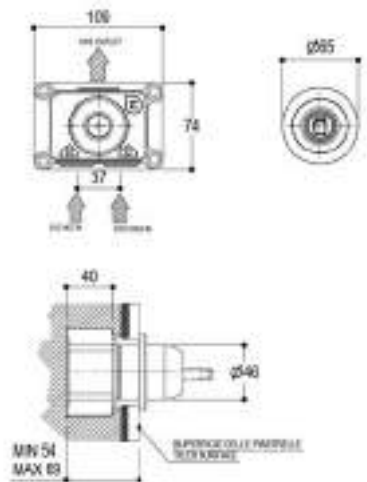



 <div style="display: flex; justify-content: space-around; margin-top: 10px;"> <div style="border: 1px solid black; padding: 2px; font-size: 8px;">IN 1/2"</div> <div style="border: 1px solid black; padding: 2px; font-size: 8px;">OUT 1/2"</div> <div style="border: 1px solid black; padding: 2px; font-size: 8px;">X</div> </div>	<p>Miscelatore monocomando ad incasso per doccia/lavabo <i>Built-in single lever shower/basin mixer</i> <i>UP-Einhandmischer für Dusche/Waschtisch</i> <i>Mitigeur monocommande à encastrer pour douche/lavabo</i> <i>Mezclador monomando empotrado para ducha/lavabo</i></p> <hr/> <p>una uscita completo di parti interne _ senza comando [PR51MC10x] _ one way _ complete of inner parts _ without handle [PR51MC10x] _ Ein Abgang _ komplett mit UP-Teilen _ ohne Griff [PR51MC10x] _ une sortie _ complet avec parties internes _ sans commande [PR51MC10x] _ una salida _ completo de partes internas _ sin mando [PR51MC10x]</p>	
---	---	---

	<p>Parti esterne <i>Outer parts / Fertigset / Parties externes / Partes externas</i></p>	<p>PR51FN201 CRL IX, CRB, BLX, BRX, C03, C04, F31, F34 DOR, GOX, CHX, F32, F33, F36, F37</p>
---	--	--

	<p>Parti da incasso <i>Built-in parts / UP-teile / Parties internes / Partes internas</i></p>	<p>E0BA0143</p>
--	---	------------------------

<p>Miscelatore completo (senza comando) <i>Complete mixer (without handle) / Vollständige Mischer (ohne Griff) / Mitigeur complete (sans commande) / Mezclador completo (sin mando)</i></p>	<p>PR51FM201 CRL IX, CRB, BLX, BRX, C03, C04, F31, F34 DOR, GOX, CHX, F32, F33, F36, F37</p>
---	--

+ Comando / Handles / Griff / Commande / Mando

<p>Comando PRISMA <i>Handle PRISMA / Griff PRISMA / Commande PRISMA / Mando PRISMA</i></p>  <p>PR51MC101</p> <p>CRL IX, CRB, BLX, BRX, C03, C04, F31, F34 DOR, GOX, CHX, F32, F33, F36, F37</p>	<p>Comando TRATTO <i>Handle TRATTO / Griff TRATTO / Commande TRATTO / Mando TRATTO</i></p>  <p>PR51MC102</p> <p>CRL IX, CRB, BLX, BRX, C03, C04, F31, F34 DOR, GOX, CHX, F32, F33, F36, F37</p>	<p>Comando RIGO <i>Handle RIGO / Griff RIGO / Commande RIGO / Mando RIGO</i></p>  <p>PR51MC103</p> <p>CRL IX, CRB, BLX, BRX, C03, C04, F31, F34 DOR, GOX, CHX, F32, F33, F36, F37</p>	<p>Comando PUNTO <i>Handle PUNTO / Griff PUNTO / Commande PUNTO / Mando PUNTO</i></p>  <p>PR51MC104</p> <p>CRL IX, CRB, BLX, BRX, C03, C04, F31, F34 DOR, GOX, CHX, F32, F33, F36, F37</p>
--	--	--	---

Accessori / Accessories / Zubehör / Accessoires / Accesorios

Prolunghe / Extensions / Verlängerungen / Rallonges / Prolongadoras & Ricambi / Spare parts / Ersatzteile / Pièces de rechange / Recambios

 <p>+20mm RCMB054H1 pag. 1202</p>	 <p>+40mm RCMB054H2 pag. 1202</p>	 <p>RCMB015 pag. 1213</p>	 <p>RCMB742 pag. 1231</p>	 <p>RCMBA146 pag. 1249</p>
--	--	--	--	---

Miscelatore e comando venduti separatamente
Mixer and handle sold separately / Mischer und Griff separat verkauf / Mitigeur et manette vendus séparément / Mezclador y mando vendidos separatamente



Staffa verticale di fissaggio per miscelatore incasso doppio
 Fixing brackets for double shower mixer for vertical installation
 Vertikale Montagehalterung für UP-Doppel-Mischer
 Support de fixation pour double mitigeur de douche à encastrer en vertical
 Soporte de montaje para mezclador empotrado vertical doble

per ·Diametro35_0139SP-0140(S/P) ·Diametro35 Impronte-PR51 ·FM101-FM201 ·Diametro35_S-PR52 ·FB101-FB201-LA221 ·Diametro35_Cross-PR53 ·FB101-FB201 ·Diametro35_Elegance-PR54 ·FB101-FB201 ·Diametro35_Inox_0139SP-0140(S/P) ·Diametro35_Inox_Concrete_0139SP-0140(S/P) ·Reverso ·6040(S/P) ·Pois-PR31 ·FB101-FB201 ·Glitter-PR32 ·FB101-FB201 ·Tie-PR34 ·FB101-FB201 ·Taormina-PR35 ·LA221 ·Tab-PR37 ·FB101-FB201 ·Tip-PR38 ·FB101-FB201 ·Haptic-PR43 ·FM101-FM201-LA221 ·DOT316-PR50 ·FB111-FB201-FB211-FB221-LA221 ·Comandi_Wellness-PR28 ·HB203-HB204-HB205 ·Comandi_Wellness-PR47 ·LA221-LA231
 for ·Diametro35_0139SP-0140(S/P) ·Diametro35 Impronte-PR51 ·FM101-FM201 ·Diametro35_S-PR52 ·FB101-FB201-LA221 ·Diametro35_Cross-PR53 ·FB101-FB201 ·Diametro35_Elegance-PR54 ·FB101-FB201 ·Diametro35_Inox_0139SP-0140(S/P) ·Diametro35_Inox_Concrete_0139SP-0140(S/P) ·Reverso ·6040(S/P) ·Pois-PR31 ·FB101-FB201 ·Glitter-PR32 ·FB101-FB201 ·Tie-PR34 ·FB101-FB201 ·Taormina-PR35 ·LA221 ·Tab-PR37 ·FB101-FB201 ·Tip-PR38 ·FB101-FB201 ·Haptic-PR43 ·FM101-FM201-LA221 ·DOT316-PR50 ·FB111-FB201-FB211-FB221-LA221 ·Comandi_Wellness-PR28 ·HB203-HB204-HB205 ·Comandi_Wellness-PR47 ·LA221-LA231
 für ·Diametro35_0139SP-0140(S/P) ·Diametro35 Impronte-PR51 ·FM101-FM201 ·Diametro35_S-PR52 ·FB101-FB201-LA221 ·Diametro35_Cross-PR53 ·FB101-FB201 ·Diametro35_Elegance-PR54 ·FB101-FB201 ·Diametro35_Inox_0139SP-0140(S/P) ·Diametro35_Inox_Concrete_0139SP-0140(S/P) ·Reverso ·6040(S/P) ·Pois-PR31 ·FB101-FB201 ·Glitter-PR32 ·FB101-FB201 ·Tie-PR34 ·FB101-FB201 ·Taormina-PR35 ·LA221 ·Tab-PR37 ·FB101-FB201 ·Tip-PR38 ·FB101-FB201 ·Haptic-PR43 ·FM101-FM201-LA221 ·DOT316-PR50 ·FB111-FB201-FB211-FB221-LA221 ·Comandi_Wellness-PR28 ·HB203-HB204-HB205 ·Comandi_Wellness-PR47 ·LA221-LA231
 pour ·Diametro35_0139SP-0140(S/P) ·Diametro35 Impronte-PR51 ·FM101-FM201 ·Diametro35_S-PR52 ·FB101-FB201-LA221 ·Diametro35_Cross-PR53 ·FB101-FB201 ·Diametro35_Elegance-PR54 ·FB101-FB201 ·Diametro35_Inox_0139SP-0140(S/P) ·Diametro35_Inox_Concrete_0139SP-0140(S/P) ·Reverso ·6040(S/P) ·Pois-PR31 ·FB101-FB201 ·Glitter-PR32 ·FB101-FB201 ·Tie-PR34 ·FB101-FB201 ·Taormina-PR35 ·LA221 ·Tab-PR37 ·FB101-FB201 ·Tip-PR38 ·FB101-FB201 ·Haptic-PR43 ·FM101-FM201-LA221 ·DOT316-PR50 ·FB111-FB201-FB211-FB221-LA221 ·Comandi_Wellness-PR28 ·HB203-HB204-HB205 ·Comandi_Wellness-PR47 ·LA221-LA231
 para ·Diametro35_0139SP-0140(S/P) ·Diametro35 Impronte-PR51 ·FM101-FM201 ·Diametro35_S-PR52 ·FB101-FB201-LA221 ·Diametro35_Cross-PR53 ·FB101-FB201 ·Diametro35_Elegance-PR54 ·FB101-FB201 ·Diametro35_Inox_0139SP-0140(S/P) ·Diametro35_Inox_Concrete_0139SP-0140(S/P) ·Reverso ·6040(S/P) ·Pois-PR31 ·FB101-FB201 ·Glitter-PR32 ·FB101-FB201 ·Tie-PR34 ·FB101-FB201 ·Taormina-PR35 ·LA221 ·Tab-PR37 ·FB101-FB201 ·Tip-PR38 ·FB101-FB201 ·Haptic-PR43 ·FM101-FM201-LA221 ·DOT316-PR50 ·FB111-FB201-FB211-FB221-LA221 ·Comandi_Wellness-PR28 ·HB203-HB204-HB205 ·Comandi_Wellness-PR47 ·LA221-LA231

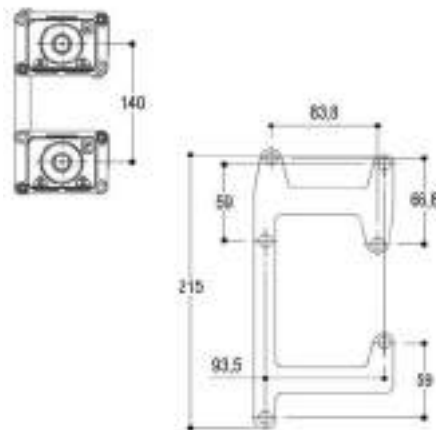

7Z0006



Staffa orizzontale di fissaggio per miscelatore incasso doppio
 Fixing brackets for double shower mixer for horizontal installation
 Horizontale Montagehalterung für UP-Doppel-Mischer
 Support de fixation pour double mitigeur à encastrer en horizontal
 Soporte de montaje para mezclador empotrado horizontal doble

per ·Diametro35_0140(S/P) ·Diametro35 Impronte-PR51 ·FM101-FM201 ·Diametro35_S-PR52 ·FB101-FB201 ·Diametro35_Cross-PR53 ·FB101-FB201 ·Diametro35_Elegance-PR54 ·FB101-FB201 ·Diametro35_Inox_0140(S/P) ·Diametro35_Inox_Concrete_0140(S/P) ·Reverso ·6040(S/P) ·Pois-PR31 ·FB101-FB201 ·Glitter-PR32 ·FB101-FB201 ·Tie-PR34 ·FB101-FB201 ·Taormina-PR35 ·LA221 ·Tab-PR37 ·FB101-FB201 ·Tip-PR38 ·FB101-FB201 ·Haptic-PR43 ·FM101-FM201 ·DOT316-PR50 ·FB111-FB201-FB211-FB221 ·Comandi_Wellness-PR28 ·HB203-HB204-HB205
 for ·Diametro35_0140(S/P) ·Diametro35 Impronte-PR51 ·FM101-FM201 ·Diametro35_S-PR52 ·FB101-FB201 ·Diametro35_Cross-PR53 ·FB101-FB201 ·Diametro35_Elegance-PR54 ·FB101-FB201 ·Diametro35_Inox_0140(S/P) ·Diametro35_Inox_Concrete_0140(S/P) ·Reverso ·6040(S/P) ·Pois-PR31 ·FB101-FB201 ·Glitter-PR32 ·FB101-FB201 ·Tie-PR34 ·FB101-FB201 ·Taormina-PR35 ·LA221 ·Tab-PR37 ·FB101-FB201 ·Tip-PR38 ·FB101-FB201 ·Haptic-PR43 ·FM101-FM201 ·DOT316-PR50 ·FB111-FB201-FB211-FB221 ·Comandi_Wellness-PR28 ·HB203-HB204-HB205
 für ·Diametro35_0140(S/P) ·Diametro35 Impronte-PR51 ·FM101-FM201 ·Diametro35_S-PR52 ·FB101-FB201 ·Diametro35_Cross-PR53 ·FB101-FB201 ·Diametro35_Elegance-PR54 ·FB101-FB201 ·Diametro35_Inox_0140(S/P) ·Diametro35_Inox_Concrete_0140(S/P) ·Reverso ·6040(S/P) ·Pois-PR31 ·FB101-FB201 ·Glitter-PR32 ·FB101-FB201 ·Tie-PR34 ·FB101-FB201 ·Taormina-PR35 ·LA221 ·Tab-PR37 ·FB101-FB201 ·Tip-PR38 ·FB101-FB201 ·Haptic-PR43 ·FM101-FM201 ·DOT316-PR50 ·FB111-FB201-FB211-FB221 ·Comandi_Wellness-PR28 ·HB203-HB204-HB205
 pour ·Diametro35_0140(S/P) ·Diametro35 Impronte-PR51 ·FM101-FM201 ·Diametro35_S-PR52 ·FB101-FB201 ·Diametro35_Cross-PR53 ·FB101-FB201 ·Diametro35_Elegance-PR54 ·FB101-FB201 ·Diametro35_Inox_0140(S/P) ·Diametro35_Inox_Concrete_0140(S/P) ·Reverso ·6040(S/P) ·Pois-PR31 ·FB101-FB201 ·Glitter-PR32 ·FB101-FB201 ·Tie-PR34 ·FB101-FB201 ·Taormina-PR35 ·LA221 ·Tab-PR37 ·FB101-FB201 ·Tip-PR38 ·FB101-FB201 ·Haptic-PR43 ·FM101-FM201 ·DOT316-PR50 ·FB111-FB201-FB211-FB221 ·Comandi_Wellness-PR28 ·HB203-HB204-HB205
 para ·Diametro35_0140(S/P) ·Diametro35 Impronte-PR51 ·FM101-FM201 ·Diametro35_S-PR52 ·FB101-FB201 ·Diametro35_Cross-PR53 ·FB101-FB201 ·Diametro35_Elegance-PR54 ·FB101-FB201 ·Diametro35_Inox_0140(S/P) ·Diametro35_Inox_Concrete_0140(S/P) ·Reverso ·6040(S/P) ·Pois-PR31 ·FB101-FB201 ·Glitter-PR32 ·FB101-FB201 ·Tie-PR34 ·FB101-FB201 ·Taormina-PR35 ·LA221 ·Tab-PR37 ·FB101-FB201 ·Tip-PR38 ·FB101-FB201 ·Haptic-PR43 ·FM101-FM201 ·DOT316-PR50 ·FB111-FB201-FB211-FB221 ·Comandi_Wellness-PR28 ·HB203-HB204-HB205

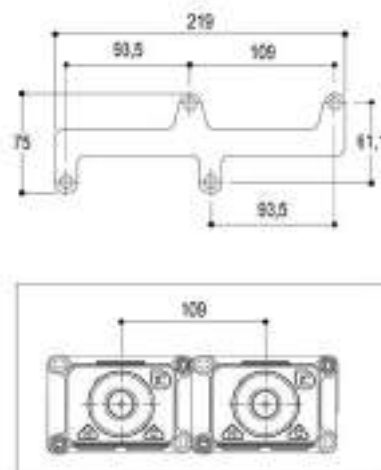

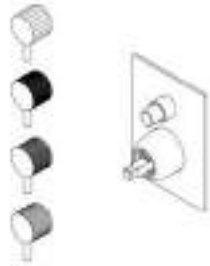

7Z0007

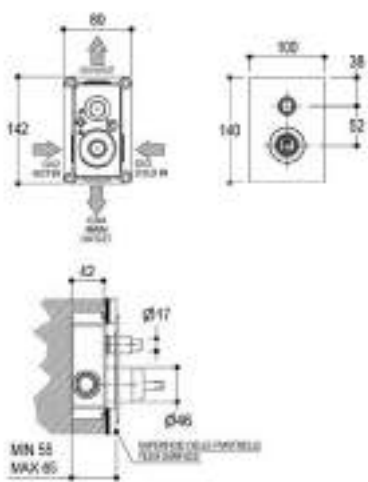

Miscelatore monocomando ad incasso per vasca/doccia
Built-in single lever bath/shower mixer
Einhandmischer für Badewanne/Dusche
Mitigeur monocommande à encastrer pour baignoire/douche
Mezclador monomando empotrado para bañera/ducha

_ due uscite _ deviatore automatico vasca/doccia _ completo di parti interne _ senza comando [PR51MC10x]
_ two ways _ automatic diverter bath/shower _ with inner parts _ without handle [PR51MC10x]
Zwei Abgänge _ Automatische Umstellung von Wanne auf Dusche _ mit UP-Teilen _ ohne Griff [PR51MC10x]
_ deux sorties _ inversion automatique bain/douche _ avec parties internes _ sans commande [PR51MC10x]
_ dos salidas _ desviador automático bañera/ducha _ completo de partes internas _ sin mando [PR51MC10x]







Parti esterne
Outer parts / Fertigset / Parties externes / Partes externas

PR51GN101 **CRL**
IX, CRB, BLX, BRX, C03, C04, F31, F34
DOR, GOX, CHX, F32, F33, F36, F37







Parti da incasso
Built-in parts / UP-teile / Parties internes / Partes internas

E0BA0153

Miscelatore completo (senza comando)
Complete mixer (without handle) / Vollständige Mischer (ohne Griff) / Mitigeur complete (sans commande) / Mezclador completo (sin mando)

PR51GM101 **CRL**
IX, CRB, BLX, BRX, C03, C04, F31, F34
DOR, GOX, CHX, F32, F33, F36, F37

+ Comando / Handles / Griff / Commande / Mando

<p>Comando PRISMA <i>Handle PRISMA / Griff PRISMA / Commande PRISMA / Mando PRISMA</i></p>  <p>PR51MC101</p> <p>CRL IX, CRB, BLX, BRX, C03, C04, F31, F34 DOR, GOX, CHX, F32, F33, F36, F37</p>	<p>Comando TRATTO <i>Handle TRATTO / Griff TRATTO / Commande TRATTO / Mando TRATTO</i></p>  <p>PR51MC102</p> <p>CRL IX, CRB, BLX, BRX, C03, C04, F31, F34 DOR, GOX, CHX, F32, F33, F36, F37</p>	<p>Comando RIGO <i>Handle RIGO / Griff RIGO / Commande RIGO / Mando RIGO</i></p>  <p>PR51MC103</p> <p>CRL IX, CRB, BLX, BRX, C03, C04, F31, F34 DOR, GOX, CHX, F32, F33, F36, F37</p>	<p>Comando PUNTO <i>Handle PUNTO / Griff PUNTO / Commande PUNTO / Mando PUNTO</i></p>  <p>PR51MC104</p> <p>CRL IX, CRB, BLX, BRX, C03, C04, F31, F34 DOR, GOX, CHX, F32, F33, F36, F37</p>
--	--	--	---

Accessori / Accessories / Zubehör / Accessoires / Accesorios

Prolunghe / Extensions / Verlängerungen / Rallonges / Prolongadoras & Ricambi / Spare parts / Ersatzteile / Pièces de rechange / Recambios

					
+20mm	+40mm				
RCMB069H1 pag. 1202	RCMB069H2 pag. 1203	RCMB015 pag. 1213	RCMB035 pag. 1214	RCMB742 pag. 1231	RCMBA156 pag. 1250

Miscelatore e comando venduti separatamente
Mixer and handle sold separately / Mischer und Griff separat verkauf / Mitigeur et manette vendus séparément / Mezclador y mando vendidos separatamente

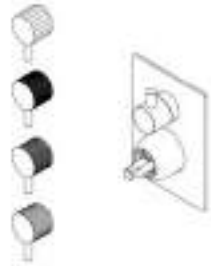

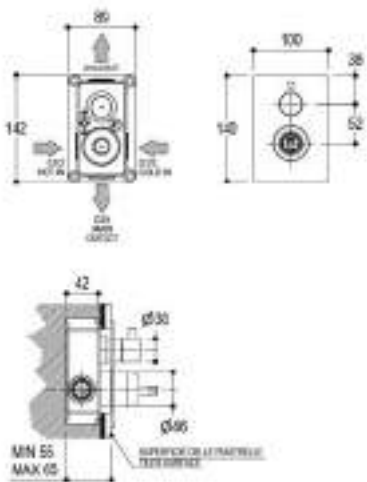

Miscelatore monocomando ad incasso per vasca/doccia
Built-in single lever bath/shower mixer
Einhandmischer für Badewanne/Dusche
Mitigeur monocommande à encastrer pour baignoire/douche
Mezclador monomando empotrado para bañera/ducha

_ due uscite con deviatore rotativo _ completo di parti interne _ senza comando [PR51MC10x]
two ways with rotative diverter _ complete of inner parts _ without handle [PR51MC10x]
zwei Abgänge mit Drehumsteller _ komplett mit UP-Teilen _ ohne Griff [PR51MC10x]
_ deux sorties avec inverseur rotatif _ complet avec parties internes _ sans commande [PR51MC10x]
_ dos salidas con mando desviador giratorio _ completo de partes internas _ sin mando [PR51MC10x]











Parti esterne
Outer parts / Fertigset / Parties externes / Partes externas

PR51GN111 CRL
IX, CRB, BLX, BRX, C03, C04, F31, F34
DOR, GOX, CHX, F32, F33, F36, F37



Parti da incasso
Built-in parts / UP-teile / Parties internes / Partes internas

PM0020M

Miscelatore completo (senza comando)
Complete mixer (without handle) / Vollständige Mischer (ohne Griff) / Mitigeur complete (sans commande) / Mezclador completo (sin mando)

PR51GM111 CRL
IX, CRB, BLX, BRX, C03, C04, F31, F34
DOR, GOX, CHX, F32, F33, F36, F37

+ Comando / Handles / Griff / Commande / Mando

Comando PRISMA
Handle PRISMA / Griff PRISMA / Commande PRISMA / Mando PRISMA



PR51MC101

CRL
IX, CRB, BLX, BRX, C03, C04, F31, F34
DOR, GOX, CHX, F32, F33, F36, F37

Comando TRATTO
Handle TRATTO / Griff TRATTO / Commande TRATTO / Mando TRATTO



PR51MC102

CRL
IX, CRB, BLX, BRX, C03, C04, F31, F34
DOR, GOX, CHX, F32, F33, F36, F37

Comando RIGO
Handle RIGO / Griff RIGO / Commande RIGO / Mando RIGO



PR51MC103

CRL
IX, CRB, BLX, BRX, C03, C04, F31, F34
DOR, GOX, CHX, F32, F33, F36, F37

Comando PUNTO
Handle PUNTO / Griff PUNTO / Commande PUNTO / Mando PUNTO



PR51MC104

CRL
IX, CRB, BLX, BRX, C03, C04, F31, F34
DOR, GOX, CHX, F32, F33, F36, F37

Accessori / Accessories / Zubehör / Accessoires / Accesorios

Ricambi / Spare parts / Ersatzteile / Pièces de rechange / Recambios



RCMB015
 pag. 1213



RCMB742
 pag. 1231



RCMB108
 pag. 1246



RCMB153
 pag. 1249



RCMB157
 pag. 1250

Miscelatore e comando venduti separatamente

Mixer and handle sold separately / Mischer und Griff separat verkauft / Mitigeur et manette vendus séparément / Mezclador y mando vendidos separadamente



Miscelatore monocomando ad incasso per vasca/doccia
Built-in single lever bath/shower mixer
Einhandmischer für Badewanne/Dusche
Mitigeur monocommande à encastrer pour baignoire/douche
Mezclador monomando empotrado para bañera/ducha

due uscite con deviatore automatico _ piastra esterna _ doccetta Ø24mm in ottone con flessibile da 1500mm _ completo di parti interne _ senza comando [PR51MC10x]
two ways with automatic diverter _ external plate _ Ø24mm brass hand shower with 1500mm flexible hose _ complete of inner parts _ without handle [PR51MC10x]
zwei Abgänge mit automatische Umstellung _ Montageplatte _ Handbrause Ø24mm aus messing mit Schlauch 1500mm _ komplett mit UP-Teilen _ ohne Griff [PR51MC10x]
deux sorties avec inverseur automatique _ plaque exterieure _ douchette Ø24mm en laiton avec flexible de 1500mm _ complet avec parties internes _ sans commande [PR51MC10x]
dos/tres salidas con mando desviador automático _ plancha externa _ ducha teléfono Ø24mm en latón con flexible de 1500mm _ plancha externa _ completo de partes internas _ sin mando [PR51MC10x]

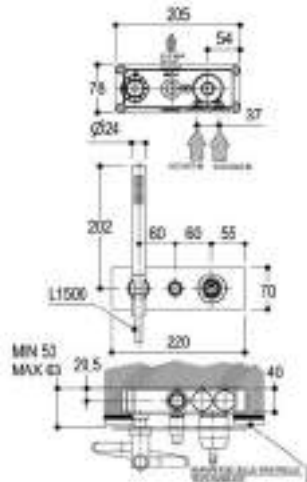

IN
1/2"

OUT
1/2"





Parti esterne
Outer parts / Fertigset / Parties externes / Partes externas

PR51GR102

CRL
IX, CRB, BLX, BRX, C03, C04, F31, F34
DOR, GOX, CHX, F32, F33, F36, F37



Parti da incasso
Built-in parts / UP-teile / Parties internes / Partes internas





PM0020D

Miscelatore completo (senza comando)
Complete mixer (without handle) / Vollständige Mischer (ohne Griff) / Mitigeur complete (sans commande) / Mezclador completo (sin mando)

PR51GQ102

CRL
IX, CRB, BLX, BRX, C03, C04, F31, F34
DOR, GOX, CHX, F32, F33, F36, F37

+ Comando / Handles / Griff / Commande / Mando

<p>Comando PRISMA <i>Handle PRISMA / Griff PRISMA / Commande PRISMA / Mando PRISMA</i></p>  <p>PR51MC101</p> <p>CRL IX, CRB, BLX, BRX, C03, C04, F31, F34 DOR, GOX, CHX, F32, F33, F36, F37</p>	<p>Comando TRATTO <i>Handle TRATTO / Griff TRATTO / Commande TRATTO / Mando TRATTO</i></p>  <p>PR51MC102</p> <p>CRL IX, CRB, BLX, BRX, C03, C04, F31, F34 DOR, GOX, CHX, F32, F33, F36, F37</p>	<p>Comando RIGO <i>Handle RIGO / Griff RIGO / Commande RIGO / Mando RIGO</i></p>  <p>PR51MC103</p> <p>CRL IX, CRB, BLX, BRX, C03, C04, F31, F34 DOR, GOX, CHX, F32, F33, F36, F37</p>	<p>Comando PUNTO <i>Handle PUNTO / Griff PUNTO / Commande PUNTO / Mando PUNTO</i></p>  <p>PR51MC104</p> <p>CRL IX, CRB, BLX, BRX, C03, C04, F31, F34 DOR, GOX, CHX, F32, F33, F36, F37</p>
--	--	--	---

Accessori / Accessories / Zubehör / Accessoires / Accesorios

Prolunghe / Extensions / Verlängerungen / Rallonges / Prolongadoras & Ricambi / Spare parts / Ersatzteile / Pièces de rechange / Recambios

					
+20mm	+40mm				
RCMB521H1 pag. 1203	RCMB521H2 pag. 1203	RCMB015 pag. 1213	RCMB035 pag. 1214	RCMB742 pag. 1231	RCMBA159 pag. 1250

Miscelatore e comando venduti separatamente
Mixer and handle sold separately / Mischer und Griff separat verkauf / Mitigeur et manette vendus séparément / Mezclador y mando vendidos separatamente



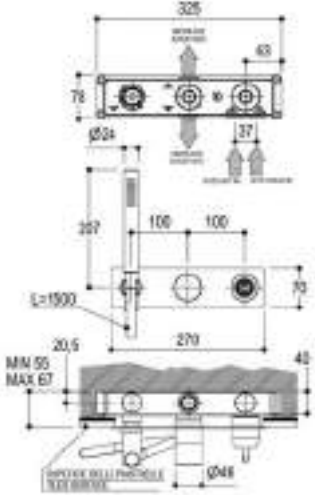

Miscelatore monocomando ad incasso per vasca/doccia
Built-in single lever bath/shower mixer
Einhandmischer für Badewanne/Dusche
Mitigeur monocommande à encastrer pour baignoire/douche
Mezclador monomando empotrado para bañera/ducha

due/tre uscite con deviatore rotativo _ piastra esterna _ doccetta
Ø24mm in ottone con flessibile da 1500mm _ completo di parti interne _ senza comando [PR51MC10x]
_ two/three ways with rotative diverter _ external plate _ Ø24mm brass hand shower with 1500mm flexible hose _ complete of inner parts _ without handle [PR51MC10x]
_ zwei/drei Abgänge mit Drehumsteller _ Montageplatte _ Handbrause Ø24mm aus messing mit Schlauch 1500mm _ komplett mit UP-Teilen _ ohne Griff [PR51MC10x]
_ deux/trois sorties avec inverseur rotatif _ plaque exterieure _ douchette Ø24mm en laiton avec flexible de 1500mm _ complet avec parties internes _ sans commande [PR51MC10x]
_ dos/tres salidas con mando desviador giratorio _ plancha externa _ ducha teléfono Ø24mm en latón con flexible de 1500mm _ plancha externa _ completo de partes internas _ sin mando [PR51MC10x]











Parti esterne
Outer parts / Fertigset / Parties externes / Partes externas

PR51GR101

CRL
IX, CRB, BLX, BRX, C03, C04, F31, F34
DOR, GOX, CHX, F32, F33, F36, F37



Parti da incasso
Built-in parts / UP-teile / Parties internes / Partes internas





PM0020L

Miscelatore completo (senza comando)
Complete mixer (without handle) / Vollständige Mischer (ohne Griff) / Mitigeur complete (sans commande) / Mezclador completo (sin mando)

PR51GQ101

CRL
IX, CRB, BLX, BRX, C03, C04, F31, F34
DOR, GOX, CHX, F32, F33, F36, F37

+ Comando / Handles / Griff / Commande / Mando

<p>Comando PRISMA <i>Handle PRISMA / Griff PRISMA / Commande PRISMA / Mando PRISMA</i></p>  <p>PR51MC101</p> <p>CRL IX, CRB, BLX, BRX, C03, C04, F31, F34 DOR, GOX, CHX, F32, F33, F36, F37</p>	<p>Comando TRATTO <i>Handle TRATTO / Griff TRATTO / Commande TRATTO / Mando TRATTO</i></p>  <p>PR51MC102</p> <p>CRL IX, CRB, BLX, BRX, C03, C04, F31, F34 DOR, GOX, CHX, F32, F33, F36, F37</p>	<p>Comando RIGO <i>Handle RIGO / Griff RIGO / Commande RIGO / Mando RIGO</i></p>  <p>PR51MC103</p> <p>CRL IX, CRB, BLX, BRX, C03, C04, F31, F34 DOR, GOX, CHX, F32, F33, F36, F37</p>	<p>Comando PUNTO <i>Handle PUNTO / Griff PUNTO / Commande PUNTO / Mando PUNTO</i></p>  <p>PR51MC104</p> <p>CRL IX, CRB, BLX, BRX, C03, C04, F31, F34 DOR, GOX, CHX, F32, F33, F36, F37</p>
--	--	---	---

Accessori / Accessories / Zubehör / Accessoires / Accesorios

Ricambi / Spare parts / Ersatzteile / Pièces de rechange / Recambios

						
RCMB015 pag. 1213	RCMB742 pag. 1231	RCMB877 pag. 1237	RCMB954 pag. 1241	RCMBA129 pag. 1248	RCMBA137 pag. 1248	RCMBA158 pag. 1250

Miscelatore e comando venduti separatamente
Mixer and handle sold separately / Mischer und Griff separat verkauf / Mitigeur et manette vendus séparément / Mezclador y mando vendidos separatamente

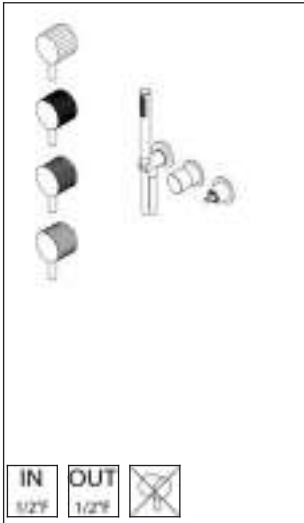

Miscelatore monocomando ad incasso per vasca/doccia
 Built-in single lever bath/shower mixer
 Einhandmischer für Badewanne/Dusche
 Mitigeur monocommande à encastrer pour baignoire/douche
 Mezclador monomando empotrado para bañera/ducha

_ due/tre uscite con deviatore rotativo _ doccetta Ø24mm in ottone con flessibile da 1500mm _ completo di parti interne _ senza comando [PR51MC10x]
 _ two/three ways with rotative diverter _ Ø24mm brass hand shower with 1500mm flexible hose _ complete of inner parts _ without handle [PR51MC10x]
 _ zwei/drei Abgänge mit Drehumsteller _ Handbrause Ø24mm aus messing mit Schlauch 1500mm _ komplett mit UP-Teilen _ ohne Griff [PR51MC10x]
 _ deux/trois sorties avec inverseur rotatif _ douchette Ø24mm en laiton avec flexible de 1500mm _ complet avec parties internes _ sans commande [PR51MC10x]
 _ dos/tres salidas con mando desviador giratorio _ ducha teléfono Ø24mm en latón con flexible de 1500mm _ plancha externa _ completo de partes internas _ sin mando [PR51MC10x]

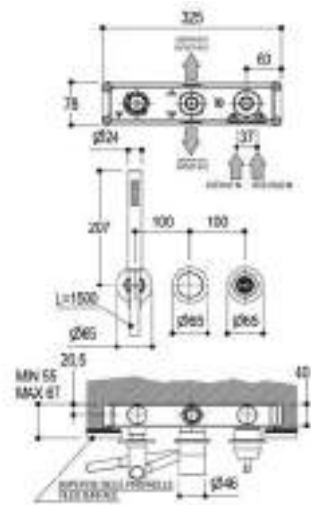

Parti esterne
 Outer parts / Fertigset / Parties externes / Partes externas

PR51GR201

CRL
 IX, CRB, BLX, BRX, C03, C04, F31, F34
 DOR, GOX, CHX, F32, F33, F36, F37



Parti da incasso
 Built-in parts / UP-teile / Parties internes / Partes internas

PM0020L

Miscelatore completo (senza comando)
 Complete mixer (without handle) / Vollständige Mischer (ohne Griff) / Mitigeur complete (sans commande) / Mezclador completo (sin mando)

PR51GQ201

CRL
 IX, CRB, BLX, BRX, C03, C04, F31, F34
 DOR, GOX, CHX, F32, F33, F36, F37

+ Comando / Handles / Griff / Commande / Mando

Comando PRISMA
 Handle PRISMA / Griff PRISMA /
 Commande PRISMA / Mando PRISMA



PR51MC101

CRL
 IX, CRB, BLX, BRX,
 C03, C04, F31, F34
 DOR, GOX, CHX, F32,
 F33, F36, F37

Comando TRATTO
 Handle TRATTO / Griff TRATTO /
 Commande TRATTO / Mando TRATTO



PR51MC102

CRL
 IX, CRB, BLX, BRX,
 C03, C04, F31, F34
 DOR, GOX, CHX, F32,
 F33, F36, F37

Comando RIGO
 Handle RIGO / Griff RIGO /
 Commande RIGO / Mando RIGO



PR51MC103

CRL
 IX, CRB, BLX, BRX,
 C03, C04, F31, F34
 DOR, GOX, CHX, F32,
 F33, F36, F37

Comando PUNTO
 Handle PUNTO / Griff PUNTO /
 Commande PUNTO / Mando PUNTO



PR51MC104

CRL
 IX, CRB, BLX, BRX,
 C03, C04, F31, F34
 DOR, GOX, CHX, F32,
 F33, F36, F37

Accessori / Accessories / Zubehör / Accessoires / Accesorios

Ricambi / Spare parts / Ersatzteile / Pièces de rechange / Recambios



RCMB015 pag. 1213 RCMB742 pag. 1231 RCMB877 pag. 1237 RCMB954 pag. 1241 RCMB129 pag. 1248 RCMB146 pag. 1249 RCMB158 pag. 1250

Miscelatore e comando venduti separatamente
 Mixer and handle sold separately / Mischer und Griff separat verkauf / Mitigeur et manette vendus séparément / Mezclador y mando vendidos separatamente



Miscelatore termostatico ad incasso
Built-in thermostatic mixer
Thermostat UP-Mischer
Mitigeur thermostatique à encastrer
Mezclador termostático empotrado

regolatore di portata _ una uscita _ completo di parti interne
flow regulator _ one way _ with inner parts
Absperrung _ Ein Abgang _ mit UP-Teilen
régulateur de débit _ une sortie _ avec parties internes
regulador de caudal _ una salida _ completo de partes internas

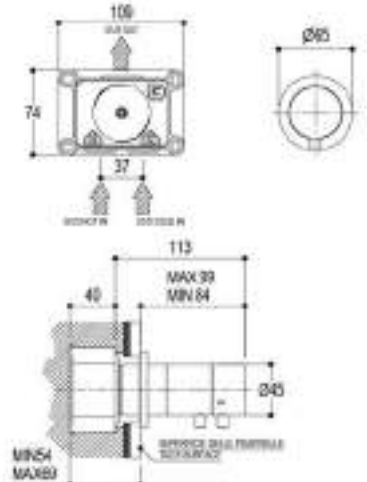

IN
1/2"

OUT
1/2"



Parti esterne
Outer parts / Fertigset / Parties externes / Partes externas

PR28HC205

CRL
IX, CRB, BLX, F31
DOR, GOX, CHX, F32, F33, F36, F37

+



Parti da incasso
Built-in parts / UP-teile / Parties internes / Partes internas

PM0030D

CRL
IX, CRB, BLX, F31
DOR, GOX, CHX, F32, F33, F36, F37

=

Miscelatore completo
Complete mixer / Vollständige Mischer / Mitigeur complete / Mezclador completo

PR28HB205

CRL
IX, CRB, BLX, F31
DOR, GOX, CHX, F32, F33, F36, F37

Accessori / Accessories / Zubehör / Accessoires / Accesorios

Prolunghe / Extensions / Verlängerungen / Rallonges / Prolongadoras & Ricambi / Spare parts / Ersatzteile / Pièces de rechange / Recambios



+20mm
RCMB556H1
pag. 1203



+40mm
RCMB556H2
pag. 1203



RCMB561
pag. 1223



RCMB562
pag. 1223



RCMB563
pag. 1223



RCMB721
pag. 1231



RCMBA146
pag. 1249

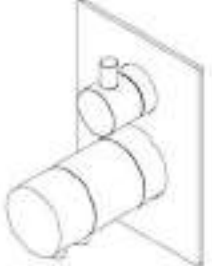

Miscelatore termostatico ad incasso
Built-in thermostatic mixer
UP-Thermostatmischer
Mitigeur thermostatique à encastrer
Mezclador termostático empotrado

_ regolatore di portata _ due uscite con deviatore rotativo _ completo di parti interne
_ flow regulator _ two ways with rotative diverter _ with inner parts
_ Absperrung _ zwei Abgänge mit Drehumsteller _ mit UP-Teilen
_ régulateur de débit _ deux sorties avec inverseur rotatif _ avec parties internes
_ regulador de caudal _ dos salidas con mando desviador giratorio _ completo de partes internas

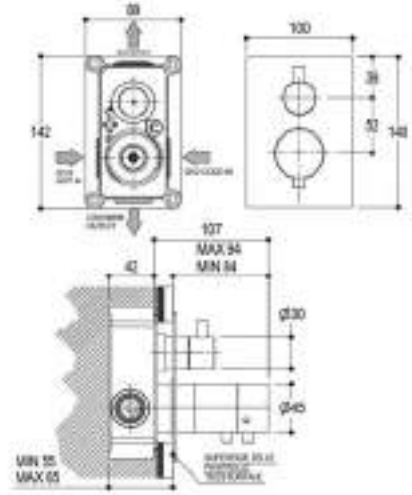

IN
1/2"

OUT
1/2"



Parti esterne
Outer parts / Fertigset / Parties externes / Partes externas

PR28HE111

CRL
IX, CRB, BLX, F31
DOR, GOX, CHX, F32, F33, F36, F37





Parti da incasso
Built-in parts / UP-teile / Parties internes / Partes internas

PM0030N

CRL
IX, CRB, BLX, F31
DOR, GOX, CHX, F32, F33, F36, F37



Miscelatore completo
Complete mixer / Vollständige Mischer / Mitigeur complete / Mezclador completo

PR28HD111

CRL
IX, CRB, BLX, F31
DOR, GOX, CHX, F32, F33, F36, F37

Accessori / Accessories / Zubehör / Accessoires / Accesorios

Ricambi / Spare parts / Ersatzteile / Pièces de rechange / Recambios

- | | | | | | | |
|---|---|---|---|---|---|---|
|  |  |  |  |  |  |  |
| RCMB561
pag. 1223 | RCMB562
pag. 1223 | RCMB563
pag. 1223 | RCMB721
pag. 1231 | RCMBA108
pag. 1246 | RCMBA153
pag. 1249 | RCMBA157
pag. 1250 |

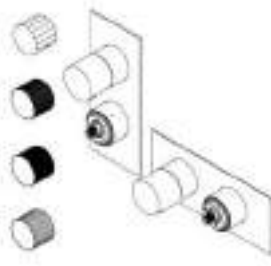

Miscelatore termostatico ad incasso
Built-in thermostatic mixer / UP-Thermostatmischer / Mitigeur thermostatique à encastrer / Mezclador termostático empotrado

_ regolatore di portata _ due/tre uscite: vasca-doccetta-soffione con posizioni di stop intermedie _ piastra esterna _ filtri e valvole di non ritorno _ completo di parti interne _ installabile in posizione verticale oppure orizzontale _ senza comando termostatico [PR51MF00x]
_ flow regulator _ two/three ways out: bath-hand shower-head shower with intermediate stop positions _ external plate _ filters and non return valves _ with inner parts _ installation in both vertical and horizontal position _ without thermostatic handle [PR51MF00x]

Durchflussregler _ Zwei- und Dreiwege-Umstellung: Badewanne-Dusche-Kopfbrause mit Zwischenhaltpositionen _ Montageplatte _ Filter und Rückschlagventil _ mit UP-Teilen _ horizontal oder vertikal installierbar _ ohne Thermostatgriff [PR51MF00x]

régulateur de débit _ deux/trois sorties: baignoire-douchette-tête de douche avec positions de stop intermédiaires _ plaque extérieure _ filtres et soupapes de non retour _ avec parties internes _ possible installation en vertical ou horizontal _ sans commande thermostatique [PR51MF00x]

_ regulador de caudal _ dos/tres salidas: bañera-ducha teléfono-rociador con posiciones de stop intermedias _ placa externa _ filtros y válvulas sin regreso _ completo de partes internas _ instalación en posición horizontal o vertical _ sin mando termostático [PR51MF00x]

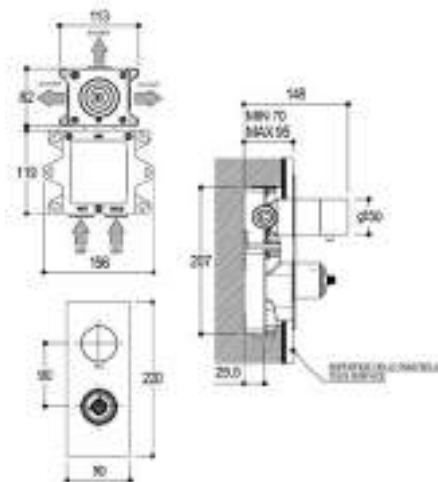





Parti esterne
Outer parts / Fertigset / Parties externes / Partes externas

PR51HU101

CRL
IX, CRB, BLX, BRX, C03, C04, F31, F34
DOR, GOX, CHX, F32, F33, F36, F37



Parti da incasso
Built-in parts / UP-teile / Parties internes / Partes internas





PM0030K

Miscelatore completo (senza comando)
Complete mixer (without handle) / Vollständige Mischer (ohne Griff) / Mitigeur complete (sans commande) / Mezclador completo (sin mando)

PR51HT101

CRL
IX, CRB, BLX, BRX, C03, C04, F31, F34
DOR, GOX, CHX, F32, F33, F36, F37

+ Comando / Handles / Griff / Commande / Mando

<p>Comando termostatico PRISMA <i>Thermostatic handle PRISMA / Thermostatgriff PRISMA / Commande thermostatique PRISMA / Mando termostático PRISMA</i></p>  <p>PR51MF001</p> <p>CRL <u>IX, CRB, BLX, BRX, C03, C04, F31, F34</u> <u>DOR, GOX, CHX, F32, F33, F36, F37</u></p>	<p>Comando termostatico TRATTO <i>Thermostatic handle TRATTO / Thermostatgriff TRATTO / Commande thermostatique TRATTO / Mando termostático TRATTO</i></p>  <p>PR51MF002</p> <p>CRL <u>IX, CRB, BLX, BRX, C03, C04, F31, F34</u> <u>DOR, GOX, CHX, F32, F33, F36, F37</u></p>	<p>Comando termostatico RIGO <i>Thermostatic handle RIGO / Thermostatgriff RIGO / Commande thermostatique RIGO / Mando termostático RIGO</i></p>  <p>PR51MF003</p> <p>CRL <u>IX, CRB, BLX, BRX, C03, C04, F31, F34</u> <u>DOR, GOX, CHX, F32, F33, F36, F37</u></p>	<p>Comando termostatico PUNTO <i>Thermostatic handle PUNTO / Thermostatgriff PUNTO / Commande thermostatique PUNTO / Mando termostático PUNTO</i></p>  <p>PR51MF004</p> <p>CRL <u>IX, CRB, BLX, BRX, C03, C04, F31, F34</u> <u>DOR, GOX, CHX, F32, F33, F36, F37</u></p>
--	--	--	---

Accessori / Accessories / Zubehör / Accessoires / Accesorios

Ricambi / Spare parts / Ersatzteile / Pièces de rechange / Recambios

					
RCMB829 pag. 1235	RCMB833 pag. 1235	RCMB840 pag. 1235	RCMB909 pag. 1240	RCMB954 pag. 1241	RCMBA020 pag. 1244

Miscelatore e comando venduti separatamente
Mixer and handle sold separately / Mischer und Griff separat verkauf / Mitigeur et manette vendus séparément / Mezclador y mando vendidos separatamente

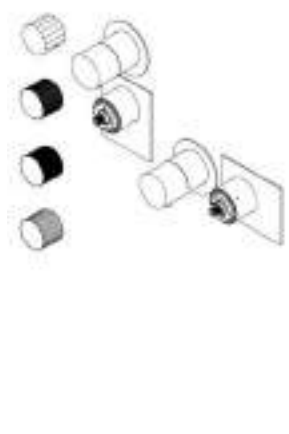

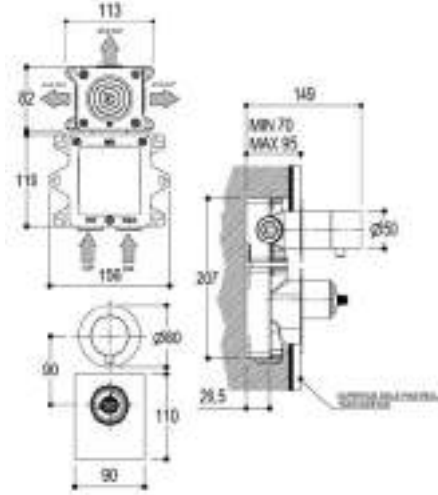

Miscelatore termostatico ad incasso
Built-in thermostatic mixer
UP-Thermostatmischer
Mitigeur thermostatique à encastrer
Mezclador termostático empotrado

_ regolatore di portata _ due/tre uscite: vasca-doccetta-soffione con posizioni di stop intermedie _ filtri e valvole di non ritorno _ completo di parti interne _ installabile in posizione verticale oppure orizzontale _ senza comando termostatico [PR51MF00x]
_ flow regulator _ two/three ways out: bath-hand shower-head shower with intermediate stop positions _ filters and non return valves _ with inner parts _ installation in both vertical and horizontal position _ without thermostatic handle [PR51MF00x]
_ Durchflussregler _ Zwei- und Dreiwege-Umstellung: Badewanne-Dusche-Kopfbrause mit Zwischenhaltpositionen _ Filter und Rückschlagventil _ mit UP-Teilen _ horizontal oder vertikal installierbar _ ohne Thermostatgriff [PR51MF00x]
_ régulateur de débit _ deux/trois sorties: baignoire-douchette-tête de douche avec positions de stop intermédiaires _ filtres et soupapes de non retour _ avec parties internes _ possible installation en vertical ou horizontal _ sans commande thermostatique [PR51MF00x]
_ regulador de caudal _ dos/tres salidas: bañera-ducha teléfono-rociador con posiciones de stop intermedias _ filtros y válvulas sin regreso _ completo de partes internas _ instalación en posición horizontal o vertical _ sin mando termostático [PR51MF00x]











Parti esterne
Outer parts / Fertigset / Parties externes / Partes externas

PR51HU201

CRL
IX, CRB, BLX, BRX, C03, C04, F31, F34
DOR, GOX, CHX, F32, F33, F36, F37



Parti da incasso
Built-in parts / UP-teile / Parties internes / Partes internas

PM0030K

=





Miscelatore completo (senza comando)
Complete mixer (without handle) / Vollständige Mischer (ohne Griff) / Mitigeur complete (sans commande) / Mezclador completo (sin mando)

PR51HT201

CRL
IX, CRB, BLX, BRX, C03, C04, F31, F34
DOR, GOX, CHX, F32, F33, F36, F37

=

+ Comando / Handles / Griff / Commande / Mando

<p>Comando termostatico PRISMA <i>Thermostatic handle PRISMA / Thermostatgriff PRISMA / Commande thermostatique PRISMA / Mando termostático PRISMA</i></p>	<p>Comando termostatico TRATTO <i>Thermostatic handle TRATTO / Thermostatgriff TRATTO / Commande thermostatique TRATTO / Mando termostático TRATTO</i></p>	<p>Comando termostatico RIGO <i>Thermostatic handle RIGO / Thermostatgriff RIGO / Commande thermostatique RIGO / Mando termostático RIGO</i></p>	<p>Comando termostatico PUNTO <i>Thermostatic handle PUNTO / Thermostatgriff PUNTO / Commande thermostatique PUNTO / Mando termostático PUNTO</i></p>
			
PR51MF001	PR51MF002	PR51MF003	PR51MF004
CRL IX, CRB, BLX, BRX, C03, C04, F31, F34 DOR, GOX, CHX, F32, F33, F36, F37	CRL IX, CRB, BLX, BRX, C03, C04, F31, F34 DOR, GOX, CHX, F32, F33, F36, F37	CRL IX, CRB, BLX, BRX, C03, C04, F31, F34 DOR, GOX, CHX, F32, F33, F36, F37	CRL IX, CRB, BLX, BRX, C03, C04, F31, F34 DOR, GOX, CHX, F32, F33, F36, F37

Accessori / Accessories / Zubehör / Accessoires / Accesorios

Ricambi / Spare parts / Ersatzteile / Pièces de rechange / Recambios

						
RCMB829 pag. 1235	RCMB833 pag. 1235	RCMB840 pag. 1235	RCMB909 pag. 1240	RCMB954 pag. 1241	RCMB996 pag. 1243	RCMBA013 pag. 1244

Miscelatore e comando venduti separatamente
Mixer and handle sold separately / Mischer und Griff separat verkauft / Mitigeur et manette vendus séparément / Mezclador y mando vendidos separatamente

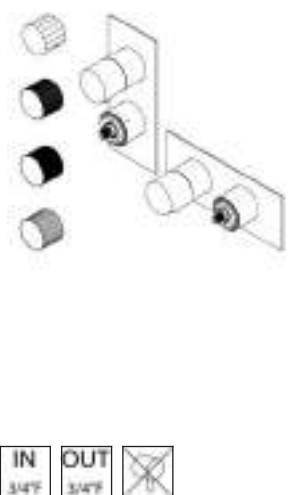

IN
3/4"

OUT
3/4"

X

Miscelatore termostatico ad incasso
Built-in thermostatic mixer
Thermostat UP-Mischer
Mitigeur thermostatique à encastrer
Mezclador termostático empotrado

_ regolatore di portata _ piastra esterna _ filtri e valvole di non ritorno _ una uscita _ completo di parti interne _ installabile in posizione verticale oppure orizzontale _ senza comando termostatico [PR51MF00x]
_ flow regulator _ external plate _ filters and non return valves _ one way with inner parts _ installation in both vertical and horizontal position _ without thermostatic handle [PR51MF00x]
_ Absperung _ Montageplatte _ Filter und Rückschlagventil _ Ein Abgang _ mit UP-Teilen _ horizontal oder vertikal installierbar _ ohne Thermostatgriff [PR51MF00x]
_ régulateur de débit _ plaque externe _ filtres et soupapes de non retour _ une sortie _ avec parties internes _ possible installation en vertical ou horizontal _ sans commande thermostatique [PR51MF00x]
_ regulador de caudal _ plancha externa _ filtros y válvulas sin regreso _ una salida _ completo de partes internas _ instalación en posición horizontal o vertical _ sin mando termostático [PR51MF00x]

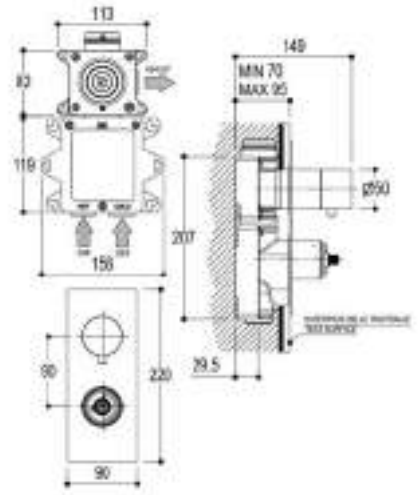



Parti esterne
Outer parts / Fertigset / Parties externes / Partes externas

PR51HQ102

CRL
IX, CRB, BLX, BRX, C03, C04, F31, F34
DOR, GOX, CHX, F32, F33, F36, F37



Parti da incasso
Built-in parts / UP-teile / Parties internes / Partes internas

PM0030H





CRL
IX, CRB, BLX, BRX, C03, C04, F31, F34
DOR, GOX, CHX, F32, F33, F36, F37

Miscelatore completo (senza comando)
Complete mixer (without handle) / Vollständige Mischer (ohne Griff) / Mitigeur complete (sans commande) / Mezclador completo (sin mando)

PR51HP102



CRL
IX, CRB, BLX, BRX, C03, C04, F31, F34
DOR, GOX, CHX, F32, F33, F36, F37

+ Comando / Handles / Griff / Commande / Mando

<p>Comando termostatico PRISMA <i>Thermostatic handle PRISMA / Thermostatgriff PRISMA / Commande thermostatique PRISMA / Mando termostático PRISMA</i></p>	<p>Comando termostatico TRATTO <i>Thermostatic handle TRATTO / Thermostatgriff TRATTO / Commande thermostatique TRATTO / Mando termostático TRATTO</i></p>	<p>Comando termostatico RIGO <i>Thermostatic handle RIGO / Thermostatgriff RIGO / Commande thermostatique RIGO / Mando termostático RIGO</i></p>	<p>Comando termostatico PUNTO <i>Thermostatic handle PUNTO / Thermostatgriff PUNTO / Commande thermostatique PUNTO / Mando termostático PUNTO</i></p>
			
PR51MF001	PR51MF002	PR51MF003	PR51MF004
<p>CRL <i>IX, CRB, BLX, BRX, C03, C04, F31, F34</i> <i>DOR, GOX, CHX, F32, F33, F36, F37</i></p>	<p>CRL <i>IX, CRB, BLX, BRX, C03, C04, F31, F34</i> <i>DOR, GOX, CHX, F32, F33, F36, F37</i></p>	<p>CRL <i>IX, CRB, BLX, BRX, C03, C04, F31, F34</i> <i>DOR, GOX, CHX, F32, F33, F36, F37</i></p>	<p>CRL <i>IX, CRB, BLX, BRX, C03, C04, F31, F34</i> <i>DOR, GOX, CHX, F32, F33, F36, F37</i></p>

Accessori / Accessories / Zubehör / Accessoires / Accesorios

Ricambi / Spare parts / Ersatzteile / Pièces de rechange / Recambios

				
RCMB353 pag. 1219	RCMB829 pag. 1235	RCMB833 pag. 1235	RCMB840 pag. 1235	RCMBA004 pag. 1243

Miscelatore e comando venduti separatamente
Mixer and handle sold separately / Mischer und Griff separat verkauf / Mitigeur et manette vendus séparément / Mezclador y mando vendidos separatamente

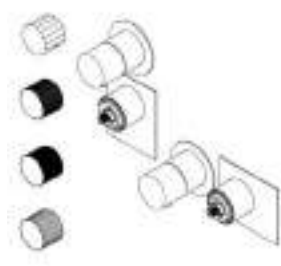

Miscelatore termostatico ad incasso
Built-in thermostatic mixer
Thermostat UP-Mischer
Mitigeur thermostatique à encastrer
Mezclador termostático empotrado

_ regolatore di portata _ filtri e valvole di non ritorno _ una uscita _ completo di parti interne _ installabile in posizione verticale oppure orizzontale _ senza comando termostatico [PR51MF00x]
_ flow regulator _ filters and non return valves _ one way _ with inner parts _ installation in both vertical and horizontal position _ without thermostatic handle [PR51MF00x]
_ Absperrung _ Filter und Rückschlagventil _ Ein Abgang _ mit UP-Teilen _ horizontal oder vertikal installierbar _ ohne Thermostatgriff [PR51MF00x]
_ régulateur de débit _ filtres et soupapes de non retour _ une sortie _ avec parties internes _ possible installation en vertical ou horizontal _ sans commande thermostatique [PR51MF00x]
_ regulador de caudal _ filtros y válvulas sin regreso _ una salida _ completo de partes internas _ instalación en posición horizontal o vertical _ sin mando termostático [PR51MF00x]

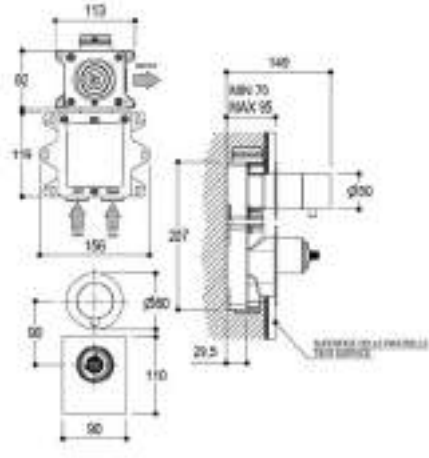





Parti esterne
Outer parts / Fertigset / Parties externes / Partes externas

PR51HQ202 **CRL**
IX, CRB, BLX, BRX, C03, C04, F31, F34
DOR, GOX, CHX, F32, F33, F36, F37



Parti da incasso
Built-in parts / UP-teile / Parties internes / Partes internas

PM0030H



Miscelatore completo (senza comando)
Complete mixer (without handle) / Vollständige Mischer (ohne Griff) / Mitigeur complete (sans commande) / Mezclador completo (sin mando)

PR51HP202 **CRL**
IX, CRB, BLX, BRX, C03, C04, F31, F34
DOR, GOX, CHX, F32, F33, F36, F37

+ Comando / Handles / Griff / Commande / Mando

Comando termostatico PRISMA
Thermostatic handle PRISMA / Thermostatgriff PRISMA / Commande thermostatique PRISMA / Mando termostático PRISMA



PR51MF001

CRL
IX, CRB, BLX, BRX, C03, C04, F31, F34
DOR, GOX, CHX, F32, F33, F36, F37

Comando termostatico TRATTO
Thermostatic handle TRATTO / Thermostatgriff TRATTO / Commande thermostatique TRATTO / Mando termostático TRATTO



PR51MF002

CRL
IX, CRB, BLX, BRX, C03, C04, F31, F34
DOR, GOX, CHX, F32, F33, F36, F37

Comando termostatico RIGO
Thermostatic handle RIGO / Thermostatgriff RIGO / Commande thermostatique RIGO / Mando termostático RIGO



PR51MF003

CRL
IX, CRB, BLX, BRX, C03, C04, F31, F34
DOR, GOX, CHX, F32, F33, F36, F37

Comando termostatico PUNTO
Thermostatic handle PUNTO / Thermostatgriff PUNTO / Commande thermostatique PUNTO / Mando termostático PUNTO



PR51MF004

CRL
IX, CRB, BLX, BRX, C03, C04, F31, F34
DOR, GOX, CHX, F32, F33, F36, F37

Accessori / Accessories / Zubehör / Accessoires / Accesorios

Ricambi / Spare parts / Ersatzteile / Pièces de rechange / Recambios



RCMB353 pag. 1219 RCMB829 pag. 1235 RCMB833 pag. 1235 RCMB840 pag. 1235 RCMB996 pag. 1243 RCMA012 pag. 1244

Miscelatore e comando venduti separatamente
Mixer and handle sold separately / Mischer und Griff separat verkauft / Mitigeur et manette vendus séparément / Mezclador y mando vendidos separatamente

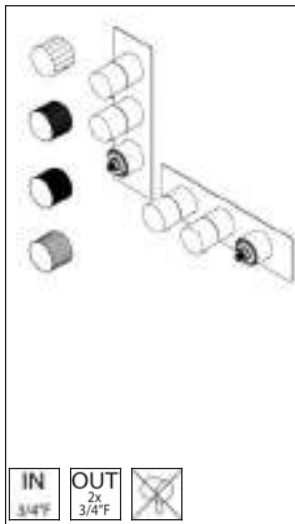

Miscelatore termostatico ad incasso

Built-in thermostatic mixer
 UP-Thermostatmischer
 Mitigeur thermostatique à encastrer
 Mezclador termostático empotrado

_ **regolatore di portata** _ **piastra esterna** _ **filtri e valvole di non ritorno** _ **due uscite indipendenti** _ **completo di parti interne** _ **installabile in posizione verticale oppure orizzontale** _ **senza comando termostatico [PR51MF00x]**

_ flow regulator _ external plate _ filters and non return valves _ two separate exits _ with inner parts _ installation in both vertical and horizontal position _ without thermostatic handle [PR51MF00x]

_ Absperrung _ Montageplatte _ Filter und Rückschlagventil _ zwei separate Abgänge _ mit UP-Teilen _ horizontal oder vertikal installierbar _ ohne Thermostatgriff [PR51MF00x]

_ régulateur de débit _ plaque externe _ filtres et soupapes de non retour _ deux sorties indépendantes _ avec parties internes _ possible installation en vertical ou horizontal _ sans commande thermostatique [PR51MF00x]

_ regulador de caudal _ plancha externa _ filtros y válvulas sin regreso _ dos salidas independientes _ completo de partes internas _ instalación en posición horizontal o vertical _ sin mando termostático [PR51MF00x]

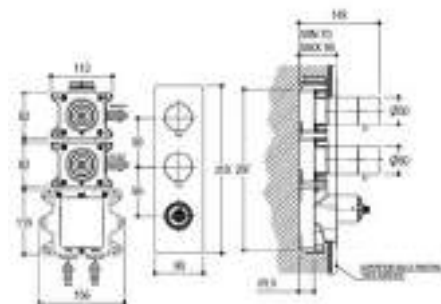

Parti esterne

Outer parts / Fertigset / Parties externes / Partes externas

PR51HS101

CRL

**IX, CRB, BLX, BRX, C03, C04, F31, F34
 DOR, GOX, CHX, F32, F33, F36, F37**



Parti da incasso

Built-in parts / UP-teile / Parties internes / Partes internas

PM0030J

+ Comando / Handles / Griff / Commande / Mando

Comando termostatico PRISMA

Thermostatic handle PRISMA /
 Thermostatgriff PRISMA /
 Commande thermostatique PRISMA /
 Mando termostático PRISMA



PR51MF001

CRL

**IX, CRB, BLX, BRX, C03, C04, F31, F34
 DOR, GOX, CHX, F32, F33, F36, F37**

Comando termostatico TRATTO

Thermostatic handle TRATTO /
 Thermostatgriff TRATTO /
 Commande thermostatique TRATTO /
 Mando termostático TRATTO



PR51MF002

CRL

**IX, CRB, BLX, BRX, C03, C04, F31, F34
 DOR, GOX, CHX, F32, F33, F36, F37**

Comando termostatico RIGO

Thermostatic handle RIGO /
 Thermostatgriff RIGO /
 Commande thermostatique RIGO /
 Mando termostático RIGO



PR51MF003

CRL

**IX, CRB, BLX, BRX, C03, C04, F31, F34
 DOR, GOX, CHX, F32, F33, F36, F37**

Comando termostatico PUNTO

Thermostatic handle PUNTO /
 Thermostatgriff PUNTO /
 Commande thermostatique PUNTO /
 Mando termostático PUNTO



PR51MF004

CRL

**IX, CRB, BLX, BRX, C03, C04, F31, F34
 DOR, GOX, CHX, F32, F33, F36, F37**

Accessori / Accessories / Zubehör / Accessoires / Accesorios

Ricambi / Spare parts / Ersatzteile / Pièces de rechange / Recambios



RCMB353
 pag. 1219



RCMB829
 pag. 1235



RCMB833
 pag. 1235



RCMB840
 pag. 1235



RCMB4005
 pag. 1243

Miscelatore e comando venduti separatamente

Mixer and handle sold separately / Mischer und Griff separat verkauf / Mitigeur et manette vendus séparément / Mezclador y mando vendidos separatamente

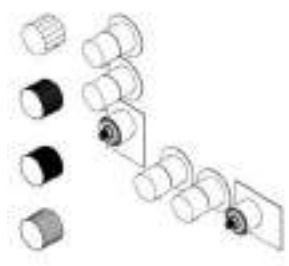

Miscelatore termostatico ad incasso
Built-in thermostatic mixer
UP-Thermostatmischer
Mitigeur thermostatique à encastrer
Mezclador termostático empotrado

_ regolatore di portata _ filtri e valvole di non ritorno _ due uscite indipendenti _ completo di parti interne _ installabile in posizione verticale oppure orizzontale _ senza comando termostatico [PR51MF00x]
_ flow regulator _ filters and non return valves _ two separate exits _ with inner parts _ installation in both vertical and horizontal position _ without thermostatic handle [PR51MF00x]
_ Absperrung _ Filter und Rückschlagventil _ zwei separate Abgänge _ mit UP-Teilen _ horizontal oder vertikal installierbar _ ohne Thermostatgriff [PR51MF00x]
_ régulateur de débit _ filtres et soupapes de non retour _ deux sorties indépendantes _ avec parties internes _ possible installation en vertical ou horizontal _ sans commande thermostatique [PR51MF00x]
_ regulador de caudal _ filtros y válvulas sin regreso _ dos salidas independientes _ completo de partes internas _ instalación en posición horizontal o vertical _ sin mando termostático [PR51MF00x]

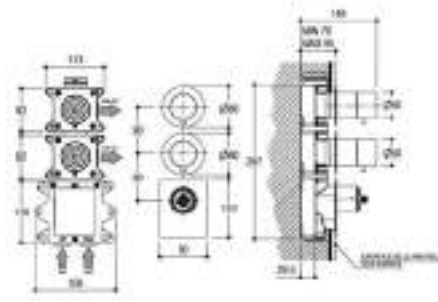





Parti esterne
Outer parts / Fertigset / Parties externes / Partes externas

PR51HS201

CRL
IX, CRB, BLX, BRX, C03, C04, F31, F34
DOR, GOX, CHX, F32, F33, F36, F37



Parti da incasso
Built-in parts / UP-teile / Parties internes / Partes internas





PM0030J

Miscelatore completo (senza comando)
Complete mixer (without handle) / Vollständige Mischer (ohne Griff) / Mitigeur complete (sans commande) / Mezclador completo (sin mando)

PR51HR201

CRL
IX, CRB, BLX, BRX, C03, C04, F31, F34
DOR, GOX, CHX, F32, F33, F36, F37

+ Comando / Handles / Griff / Commande / Mando

<p>Comando termostatico PRISMA <i>Thermostatic handle PRISMA / Thermostatgriff PRISMA / Commande thermostatique PRISMA / Mando termostático PRISMA</i></p>	<p>Comando termostatico TRATTO <i>Thermostatic handle TRATTO / Thermostatgriff TRATTO / Commande thermostatique TRATTO / Mando termostático TRATTO</i></p>	<p>Comando termostatico RIGO <i>Thermostatic handle RIGO / Thermostatgriff RIGO / Commande thermostatique RIGO / Mando termostático RIGO</i></p>	<p>Comando termostatico PUNTO <i>Thermostatic handle PUNTO / Thermostatgriff PUNTO / Commande thermostatique PUNTO / Mando termostático PUNTO</i></p>
			
PR51MF001	PR51MF002	PR51MF003	PR51MF004
CRL IX, CRB, BLX, BRX, C03, C04, F31, F34 DOR, GOX, CHX, F32, F33, F36, F37	CRL IX, CRB, BLX, BRX, C03, C04, F31, F34 DOR, GOX, CHX, F32, F33, F36, F37	CRL IX, CRB, BLX, BRX, C03, C04, F31, F34 DOR, GOX, CHX, F32, F33, F36, F37	CRL IX, CRB, BLX, BRX, C03, C04, F31, F34 DOR, GOX, CHX, F32, F33, F36, F37

Accessori / Accessories / Zubehör / Accessoires / Accesorios

Ricambi / Spare parts / Ersatzteile / Pièces de rechange / Recambios

					
RCMB353 pag. 1219	RCMB829 pag. 1235	RCMB833 pag. 1235	RCMB840 pag. 1235	RCMB996 pag. 1243	RCMBA012 pag. 1244

Miscelatore e comando venduti separatamente
Mixer and handle sold separately / Mischer und Griff separat verkauft / Mitigeur et manette vendus séparément / Mezclador y mando vendidos separatamente

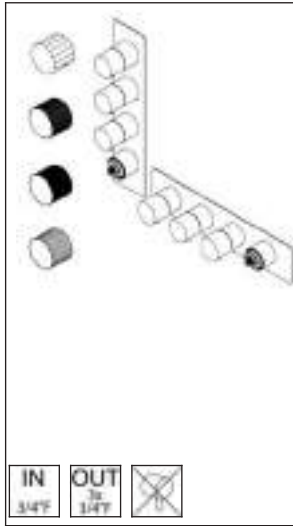

Miscelatore termostatico ad incasso

Built-in thermostatic mixer
 UP-Thermostatmischer
 Mitigeur thermostatique à encastrer
 Mezclador termostático empotrado

**_regolatore di portata _piastra esterna _filtri e valvole di non ritorno
 _tre uscite indipendenti _completo di parti interne _installabile in
 posizione verticale oppure orizzontale _senza comando termostatico
 [PR51MF00x]**

_flow regulator _external plate _filters and non return valves _three
 separate exits _with inner parts _installation in both vertical and horizontal
 position _without thermostatic handle [PR51MF00x]
 _Absperrung _Montageplatte _Filter und Rückschlagventil _drei separate
 Abgänge _mit UP-Teilen _horizontal oder vertikal installierbar _ohne
 Thermostatgriff [PR51MF00x]
 _régulateur de débit _plaque externe _filtres et soupapes de non retour
 trois sorties indépendantes _avec parties internes _possible installation en
 vertical ou horizontal _sans commande thermostatique [PR51MF00x]
 _regulador de caudal _plancha externa _filtros y válvulas sin regreso _tres
 salidas independientes _completo de partes internas _instalación en
 posición horizontal o vertical _sin mando termostático [PR51MF00x]

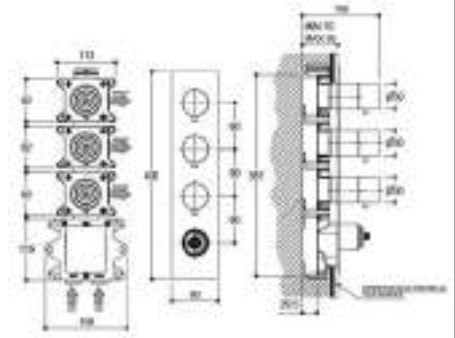

Parti esterne

Outer parts / Fertigset / Parties externes / Partes
 externas

PR51HU102

CRL

**IX, CRB, BLX, BRX, C03, C04, F31, F34
 DOR, GOX, CHX, F32, F33, F36, F37**



Parti da incasso

Built-in parts / UP-teile / Parties internes / Partes
 internas

PM0030L

+ Comando / Handles / Griff / Commande / Mando

Comando termostatico PRISMA

Thermostatic handle PRISMA /
 Thermostatgriff PRISMA /
 Commande thermostatique
 PRISMA / Mando termostático
 PRISMA



PR51MF001

CRL

**IX, CRB, BLX, BRX,
 C03, C04, F31, F34
 DOR, GOX, CHX, F32,
 F33, F36, F37**

Comando termostatico TRATTO

Thermostatic handle TRATTO /
 Thermostatgriff TRATTO /
 Commande thermostatique
 TRATTO / Mando termostático
 TRATTO



PR51MF002

CRL

**IX, CRB, BLX, BRX,
 C03, C04, F31, F34
 DOR, GOX, CHX, F32,
 F33, F36, F37**

Comando termostatico RIGO

Thermostatic handle RIGO /
 Thermostatgriff RIGO /
 Commande thermostatique
 RIGO / Mando
 termostático RIGO



PR51MF003

CRL

**IX, CRB, BLX, BRX,
 C03, C04, F31, F34
 DOR, GOX, CHX, F32,
 F33, F36, F37**

Comando termostatico PUNTO

Thermostatic handle PUNTO /
 Thermostatgriff PUNTO /
 Commande thermostatique
 PUNTO / Mando termostático
 PUNTO



PR51MF004

CRL

**IX, CRB, BLX, BRX,
 C03, C04, F31, F34
 DOR, GOX, CHX, F32,
 F33, F36, F37**

Accessori / Accessories / Zubehör / Accessoires / Accesorios

Ricambi / Spare parts / Ersatzteile / Pièces de rechange / Recambios



RCMB353
 pag. 1219



RCMB829
 pag. 1235



RCMB833
 pag. 1235



RCMB840
 pag. 1235



RCMB A006
 pag. 1243

Miscelatore e comando venduti separatamente

Mixer and handle sold separately / Mischer und Griff separat verkauf / Mitigeur et manette vendus séparément / Mezclador y mando vendidos separatamente

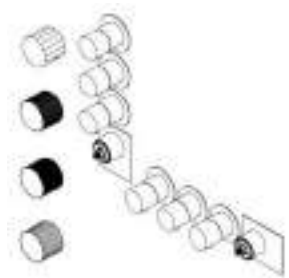

Miscelatore termostatico ad incasso
Built-in thermostatic mixer
UP-Thermostatmischer
Mitigeur thermostatique à encastrer
Mezclador termostático empotrado

_ regolatore di portata _ filtri e valvole di non ritorno _ tre uscite indipendenti _ completo di parti interne _ installabile in posizione verticale oppure orizzontale _ senza comando termostatico [PR51MF00x]
_ flow regulator _ filters and non return valves _ three separate exits _ with inner parts _ installation in both vertical and horizontal position _ without thermostatic handle [PR51MF00x]
_ Absperrung _ Filter und Rückschlagventil _ drei separate Abgänge _ mit UP-Teilen _ horizontal oder vertikal installierbar _ ohne Thermostatgriff [PR51MF00x]
_ régulateur de débit _ filtres et soupapes de non retour _ trois sorties indépendantes _ avec parties internes _ possible installation en vertical ou horizontal _ sans commande thermostatique [PR51MF00x]
_ regulador de caudal _ filtros y válvulas sin regreso _ tres salidas independientes _ completo de partes internas _ instalación en posición horizontal o vertical _ sin mando termostático [PR51MF00x]

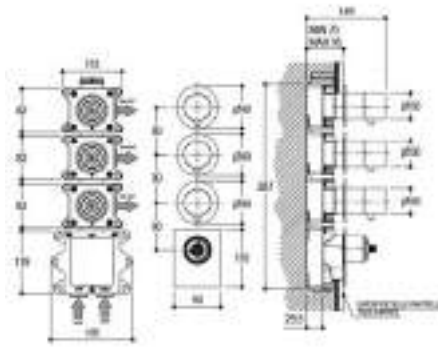





Parti esterne
Outer parts / Fertigset / Parties externes / Partes externas

PR51HU202 **CRL**

IX, CRB, BLX, BRX, C03, C04, F31, F34

DOR, GOX, CHX, F32, F33, F36, F37



Parti da incasso
Built-in parts / UP-teile / Parties internes / Partes internas

PM0030L





Miscelatore completo (senza comando)
Complete mixer (without handle) / Vollständige Mischer (ohne Griff) / Mitigeur complete (sans commande) / Mezclador completo (sin mando)

PR51HT202 **CRL**

IX, CRB, BLX, BRX, C03, C04, F31, F34

DOR, GOX, CHX, F32, F33, F36, F37

+ Comando / Handles / Griff / Commande / Mando

<p>Comando termostatico PRISMA <i>Thermostatic handle PRISMA / Thermostatgriff PRISMA / Commande thermostatique PRISMA / Mando termostático PRISMA</i></p>  <p>PR51MF001</p> <hr/> <p>CRL IX, CRB, BLX, BRX, C03, C04, F31, F34 DOR, GOX, CHX, F32, F33, F36, F37</p>	<p>Comando termostatico TRATTO <i>Thermostatic handle TRATTO / Thermostatgriff TRATTO / Commande thermostatique TRATTO / Mando termostático TRATTO</i></p>  <p>PR51MF002</p> <hr/> <p>CRL IX, CRB, BLX, BRX, C03, C04, F31, F34 DOR, GOX, CHX, F32, F33, F36, F37</p>	<p>Comando termostatico RIGO <i>Thermostatic handle RIGO / Thermostatgriff RIGO / Commande thermostatique RIGO / Mando termostático RIGO</i></p>  <p>PR51MF003</p> <hr/> <p>CRL IX, CRB, BLX, BRX, C03, C04, F31, F34 DOR, GOX, CHX, F32, F33, F36, F37</p>	<p>Comando termostatico PUNTO <i>Thermostatic handle PUNTO / Thermostatgriff PUNTO / Commande thermostatique PUNTO / Mando termostático PUNTO</i></p>  <p>PR51MF004</p> <hr/> <p>CRL IX, CRB, BLX, BRX, C03, C04, F31, F34 DOR, GOX, CHX, F32, F33, F36, F37</p>
--	--	---	---

Accessori / Accessories / Zubehör / Accessoires / Accesorios

Ricambi / Spare parts / Ersatzteile / Pièces de rechange / Recambios

					
RCMB353 pag. 1219	RCMB829 pag. 1235	RCMB833 pag. 1235	RCMB840 pag. 1235	RCMB996 pag. 1243	RCMBA012 pag. 1244

Miscelatore e comando venduti separatamente
Mixer and handle sold separately / Mischer und Griff separat verkauft / Mitigeur et manette vendus séparément / Mezclador y mando vendidos separatamente

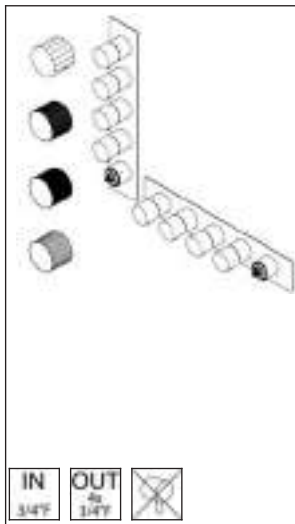

Miscelatore termostatico ad incasso

Built-in thermostatic mixer
UP-Thermostatmischer
Mitigeur thermostatique à encastrer
Mezclador termostático empotrado

**_ regolatore di portata _ piastra esterna _ filtri e valvole di non ritorno
_ quattro uscite indipendenti _ completo di parti interne _ installabile
in posizione verticale oppure orizzontale _ senza comando
termostatico [PR51MF00x]**

_ flow regulator _ external plate _ filters and non return valves _ four
separate exits _ with inner parts _ installation in both vertical and horizontal
position _ without thermostatic handle [PR51MF00x]
_ Absperrung _ Montageplatte _ Filter und Rückschlagventil _ vier separate
Abgänge _ mit UP-Teilen _ horizontal oder vertikal installierbar _ ohne
Thermostatgriff [PR51MF00x]
_ régulateur de débit _ plaque externe _ filtres et soupapes de non retour
quatre sorties indépendantes _ avec parties internes _ possible installation en
vertical ou horizontal _ sans commande thermostatique [PR51MF00x]
_ regulador de caudal _ plancha externa _ filtros y válvulas sin regreso
cuatro salidas independientes _ completo de partes internas _ instalación en
posición horizontal o vertical _ sin mando termostático [PR51MF00x]

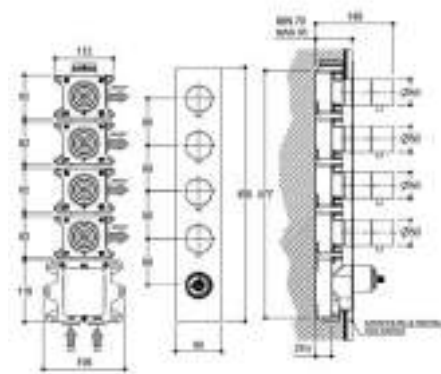

Parti esterne

Outer parts / Fertigset / Parties externes / Partes
externas

PR51HW101

CRL

**IX, CRB, BLX, BRX, C03, C04, F31, F34
DOR, GOX, CHX, F32, F33, F36, F37**



Parti da incasso

Built-in parts / UP-teile / Parties internes / Partes
internas

PM0030M

+ Comando / Handles / Griff / Commande / Mando

Comando termostatico PRISMA
Thermostatic handle PRISMA /
Thermostatgriff PRISMA /
Commande thermostatique
PRISMA / Mando termostático
PRISMA



PR51MF001

CRL

**IX, CRB, BLX, BRX,
C03, C04, F31, F34
DOR, GOX, CHX, F32,
F33, F36, F37**

Comando termostatico TRATTO
Thermostatic handle TRATTO /
Thermostatgriff TRATTO /
Commande thermostatique
TRATTO / Mando termostático
TRATTO



PR51MF002

CRL

**IX, CRB, BLX, BRX,
C03, C04, F31, F34
DOR, GOX, CHX, F32,
F33, F36, F37**

Comando termostatico RIGO
Thermostatic handle RIGO /
Thermostatgriff RIGO / Commande
thermostatique RIGO / Mando
termostático RIGO



PR51MF003

CRL

**IX, CRB, BLX, BRX,
C03, C04, F31, F34
DOR, GOX, CHX, F32,
F33, F36, F37**

Comando termostatico PUNTO
Thermostatic handle PUNTO /
Thermostatgriff PUNTO /
Commande thermostatique
PUNTO / Mando termostático
PUNTO



PR51MF004

CRL

**IX, CRB, BLX, BRX,
C03, C04, F31, F34
DOR, GOX, CHX, F32,
F33, F36, F37**

Accessori / Accessories / Zubehör / Accessoires / Accesorios

Ricambi / Spare parts / Ersatzteile / Pièces de rechange / Recambios



RCMB353
pag. 1219



RCMB829
pag. 1235



RCMB833
pag. 1235



RCMB840
pag. 1235



RCMB A007
pag. 1243

Miscelatore e comando venduti separatamente

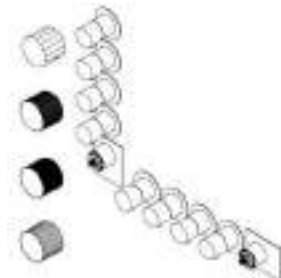

Mixer and handle sold separately / Mischer und Griff separat verkauf / Mitigeur et manette vendus séparément / Mezclador y mando vendidos separatamente

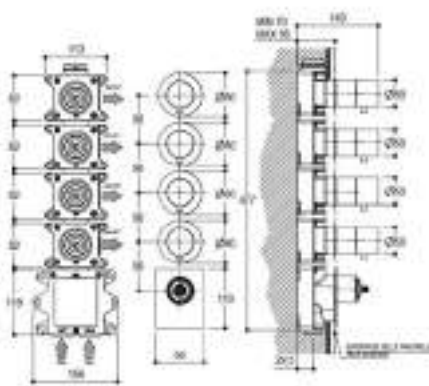

Miscelatore termostatico ad incasso
Built-in thermostatic mixer
UP-Thermostatmischer
Mitigeur thermostatique à encastrer
Mezclador termostático empotrado

_ regolatore di portata _ filtri e valvole di non ritorno _ quattro uscite indipendenti _ completo di parti interne _ installabile in posizione verticale oppure orizzontale _ senza comando termostatico [PR51MF00x]
_ flow regulator _ filters and non return valves _ four separate exits _ with inner parts _ installation in both vertical and horizontal position _ without thermostatic handle [PR51MF00x]
_ Absperrung _ Filter und Rückschlagventil _ vier separate Abgänge _ mit UP-Teilen _ horizontal oder vertikal installierbar _ ohne Thermostatgriff [PR51MF00x]
_ régulateur de débit _ filtres et soupapes de non retour _ quatre sorties indépendantes _ avec parties internes _ possible installation en vertical ou horizontal _ sans commande thermostatique [PR51MF00x]
_ regulador de caudal _ filtros y válvulas sin regreso _ cuatro salidas independientes _ completo de partes internas _ instalación en posición horizontal o vertical _ sin mando termostático [PR51MF00x]





Parti esterne
Outer parts / Fertigset / Parties externes / Partes externas

PR51HW201

CRL

IX, CRB, BLX, BRX, C03, C04, F31, F34

DOR, GOX, CHX, F32, F33, F36, F37



Parti da incasso
Built-in parts / UP-teile / Parties internes / Partes internas

PM0030M

Miscelatore completo (senza comando)
Complete mixer (without handle) / Vollständige Mischer (ohne Griff) / Mitigeur complete (sans commande) / Mezclador completo (sin mando)





PR51HV201

CRL

IX, CRB, BLX, BRX, C03, C04, F31, F34

DOR, GOX, CHX, F32, F33, F36, F37

+ Comando / Handles / Griff / Commande / Mando

<p>Comando termostatico PRISMA <i>Thermostatic handle PRISMA / Thermostatgriff PRISMA / Commande thermostatique PRISMA / Mando termostático PRISMA</i></p>  <p>PR51MF001</p> <div style="border-bottom: 1px solid black; padding: 5px;"> <p>CRL</p> <p>IX, CRB, BLX, BRX, C03, C04, F31, F34</p> <p>DOR, GOX, CHX, F32, F33, F36, F37</p> </div>	<p>Comando termostatico TRATTO <i>Thermostatic handle TRATTO / Thermostatgriff TRATTO / Commande thermostatique TRATTO / Mando termostático TRATTO</i></p>  <p>PR51MF002</p> <div style="border-bottom: 1px solid black; padding: 5px;"> <p>CRL</p> <p>IX, CRB, BLX, BRX, C03, C04, F31, F34</p> <p>DOR, GOX, CHX, F32, F33, F36, F37</p> </div>	<p>Comando termostatico RIGO <i>Thermostatic handle RIGO / Thermostatgriff RIGO / Commande thermostatique RIGO / Mando termostático RIGO</i></p>  <p>PR51MF003</p> <div style="border-bottom: 1px solid black; padding: 5px;"> <p>CRL</p> <p>IX, CRB, BLX, BRX, C03, C04, F31, F34</p> <p>DOR, GOX, CHX, F32, F33, F36, F37</p> </div>	<p>Comando termostatico PUNTO <i>Thermostatic handle PUNTO / Thermostatgriff PUNTO / Commande thermostatique PUNTO / Mando termostático PUNTO</i></p>  <p>PR51MF004</p> <div style="border-bottom: 1px solid black; padding: 5px;"> <p>CRL</p> <p>IX, CRB, BLX, BRX, C03, C04, F31, F34</p> <p>DOR, GOX, CHX, F32, F33, F36, F37</p> </div>
---	---	--	--

Accessori / Accessories / Zubehör / Accessoires / Accesorios

Ricambi / Spare parts / Ersatzteile / Pièces de rechange / Recambios

					
RCMB353 pag. 1219	RCMB829 pag. 1235	RCMB833 pag. 1235	RCMB840 pag. 1235	RCMB996 pag. 1243	RCMBA012 pag. 1244

Miscelatore e comando venduti separatamente
Mixer and handle sold separately / Mischer und Griff separat verkauft / Mitigeur et manette vendus séparément / Mezclador y mando vendidos separadamente

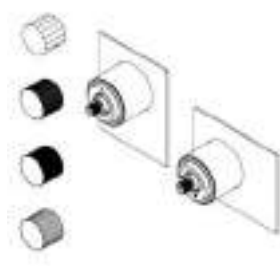

Miscelatore termostatico ad incasso
Built-in thermostatic mixer / UP-Thermostatmischer / Mitigeur thermostatique à encastrer / Mezclador termostático empotrado

_ piastra esterna _ regolazione di temperatura _ filtri e valvole di non ritorno _ una uscita _ completo di parti interne _ installabile in posizione verticale oppure orizzontale _ senza comando [PR51MF00x]
_ external plate _ temperature regulation _ filters and non return valves _ one way _ with inner parts _ installation in both vertical and horizontal position _ without handle [PR51MF00x]

Montageplatte _ nur Temperaturregler _ Filter und Rückschlagventil _ Ein Abgang _ komplett mit UP-Teilen _ horizontal oder vertikal installierbar _ ohne Griff [PR51MF00x]

_ plaque externe _ réglage de température _ filtres et soupapes de non retour _ one sortie _ avec parties internes _ possible installation en vertical ou horizontal _ sans commande [PR51MF00x]

_ plancha externa _ regulación de temperatura _ filtros y válvulas sin regreso _ una salida _ completo de partes internas _ instalación en posición horizontal o vertical _ sin mando [PR51MF00x]

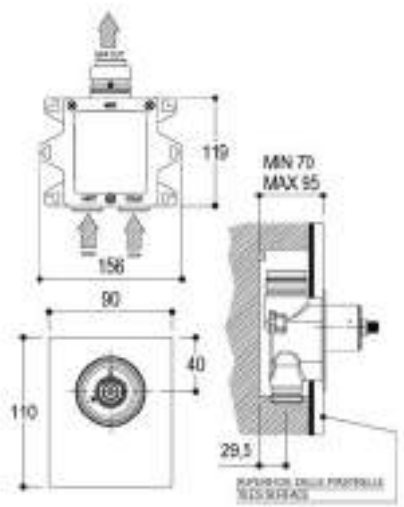





Parti esterne
Outer parts / Fertigset / Parties externes / Partes externas

PR51HQ101

CRL
 IX, CRB, BLX, BRX, C03, C04, F31, F34
 DOR, GOX, CHX, F32, F33, F36, F37



Parti da incasso
Built-in parts / UP-teile / Parties internes / Partes internas

PM0030G





CRL
 IX, CRB, BLX, BRX, C03, C04, F31, F34
 DOR, GOX, CHX, F32, F33, F36, F37

Miscelatore completo (senza comando)
Complete mixer (without handle) / Vollständige Mischer (ohne Griff) / Mitigeur complete (sans commande) / Mezclador completo (sin mando)

PR51HP101

CRL
 IX, CRB, BLX, BRX, C03, C04, F31, F34
 DOR, GOX, CHX, F32, F33, F36, F37

+ Comando / Handles / Griff / Commande / Mando

<p>Comando termostatico PRISMA <i>Thermostatic handle PRISMA / Thermostatgriff PRISMA / Commande thermostatique PRISMA / Mando termostático PRISMA</i></p>	<p>Comando termostatico TRATTO <i>Thermostatic handle TRATTO / Thermostatgriff TRATTO / Commande thermostatique TRATTO / Mando termostático TRATTO</i></p>	<p>Comando termostatico RIGO <i>Thermostatic handle RIGO / Thermostatgriff RIGO / Commande thermostatique RIGO / Mando termostático RIGO</i></p>	<p>Comando termostatico PUNTO <i>Thermostatic handle PUNTO / Thermostatgriff PUNTO / Commande thermostatique PUNTO / Mando termostático PUNTO</i></p>
			
PR51MF001	PR51MF002	PR51MF003	PR51MF004
<p>CRL IX, CRB, BLX, BRX, C03, C04, F31, F34 DOR, GOX, CHX, F32, F33, F36, F37</p>	<p>CRL IX, CRB, BLX, BRX, C03, C04, F31, F34 DOR, GOX, CHX, F32, F33, F36, F37</p>	<p>CRL IX, CRB, BLX, BRX, C03, C04, F31, F34 DOR, GOX, CHX, F32, F33, F36, F37</p>	<p>CRL IX, CRB, BLX, BRX, C03, C04, F31, F34 DOR, GOX, CHX, F32, F33, F36, F37</p>

Accessori / Accessories / Zubehör / Accessoires / Accesorios

Ricambi / Spare parts / Ersatzteile / Pièces de rechange / Recambios

 RCMB833 pag. 1235	 RCMB840 pag. 1235	 RCMB996 pag. 1243
---	---	---

Miscelatore e comando venduti separatamente
Mixer and handle sold separately / Mischer und Griff separat verkauf / Mitigeur et manette vendus séparément / Mezclador y mando vendidos separatamente

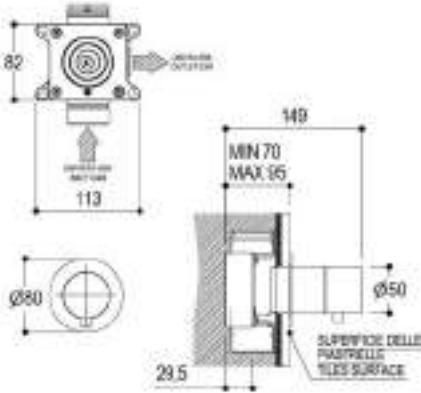
 <div data-bbox="88 549 204 606"> <p>IN 147</p> <p>OUT 147</p> </div>	<p>Rubinetto ad incasso <i>Built-in tap</i> <i>UP-Absperrventil</i> <i>Robinet à encastrer</i> <i>Grifo empotrado</i></p> <p>_ regolazione di portata _ vitone ceramico _ una uscita _ completo di parti interne <i>_ flow regulation _ ceramic disk cartridge _ one way _ with inner parts</i> <i>_ Ein Abgang _ keramikoberteil _ mit UP-Teilen</i> <i>_ réglage de débit _ une sortie _ tête céramique _ avec parties internes</i> <i>_ regulación de caudal _ cabeza con discos cerámicos _ una salida _ completo de partes internas</i></p>	
--	--	---

	<p>Parti esterne <i>Outer parts / Fertigset / Parties externes / Partes externas</i></p>	<p>PR47JB201 CRL</p> <p>IX, CRB, BLX, BRX, C03, C04, F31, F34</p> <p>DOR, GOX, CHX, F32, F33, F36, F37</p>
---	--	---

	<p>Parti da incasso <i>Built-in parts / UP-teile / Parties internes / Partes internas</i></p>	<p>PM00404</p>
--	---	-----------------------

<p>Miscelatore completo <i>Complete mixer / Vollständige Mischer / Mitigeur complete / Mezclador completo</i></p>	<p>PR47JA201 CRL</p> <p>IX, CRB, BLX, BRX, C03, C04, F31, F34</p> <p>DOR, GOX, CHX, F32, F33, F36, F37</p>
---	---

Accessori / Accessories / Zubehör / Accessoires / Accesorios

Ricambi / Spare parts / Ersatzteile / Pièces de rechange / Recambios

 <p>RCMB353 pag. 1219</p>	 <p>RCMB829 pag. 1235</p>	 <p>RCMBA012 pag. 1244</p>
--	--	---



Rubinetto di arresto anche per installazione in serie
Built-in stop valve connectable in series
UP-Absperrventil auch für Serieninstallation
Robinet d'arrêt a encastrer aussi pour l'installation en série
Valvula de cierre tambien para instalaciòn en serie

_ 1 ingresso _ 1 uscita laterale comandata da vitone ceramico con posizione di stop e regolazione di portata _ 1 uscita superiore sempre aperta per alimentazione in serie _ completo di parti interne
_ 1 inlet _ 1 lateral way controllabile by ceramic headwork with stop position and flow regulator _ 1 upper way constantly open for connection in series _ with inner parts
_ 1 Zutritt _ 1 Seitenabgang bei einem Keramikoberteil bedient mit Stopposition und Durchflussmengeregelung _ 1 Obere Abgang immer geöffnet für Seriensorgung _ mit UP-Teilen
_ 1 entrée _ 1 sortie latérale commandée par une tête céramique avec position de stop et régulation du débit _ 1 sortie supérieure toujours ouverte pour alimentation en série _ complet de parties internes
_ 1 entrada _ 1 salida lateral mandada para una cabeza con discos cerámicos con posición de stop y regulador de caudal _ 1 salida superior siempre abierta para alimentación en serie _ completa de partes internas

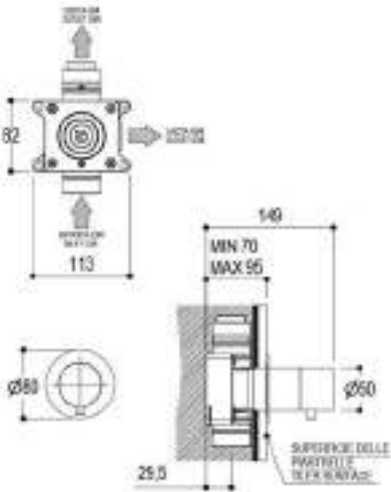

IN
3/4"

OUT
2x
3/4"



Parti esterne
Outer parts / Fertigset / Parties externes / Partes externas

PR47JB201 **CRL**
IX, CRB, BLX, BRX, C03, C04, F31, F34
DOR, GOX, CHX, F32, F33, F36, F37



Parti da incasso
Built-in parts / UP-teile / Parties internes / Partes internas

PM00405

Miscelatore completo
Complete mixer / Vollständige Mischer / Mitigeur complete / Mezclador completo

PR47JA202 **CRL**
IX, CRB, BLX, BRX, C03, C04, F31, F34
DOR, GOX, CHX, F32, F33, F36, F37

Accessori / Accessories / Zubehör / Accessoires / Accesorios

Ricambi / Spare parts / Ersatzteile / Pièces de rechange / Recambios



RCMB353
pag. 1219



RCMB829
pag. 1235



RCMBA012
pag. 1244



Deviatore ad incasso con regolazione portata
 Built-in diverter with flow regulator
 UP-Umstellung mit Absperrung
 Inverseur à encastrer avec régulateur de débit
 Desviador empotrado con regulador de potencia

_ tre uscite: vasca-doccetta-soffione con posizioni di stop intermedie _ completo di parti interne
 _ three ways out: bath-hand shower-head shower with intermediate stop positions _ with inner parts
 Dreiweg-Umsteller: Badewanne-Dusche-Kopfbrause mit Zwischenhaltpositionen _ mit UP-Teilen
 _ trois sorties: baignoire-douchette-tête de douche avec positions de stop intermédiaires _ avec parties internes
 _ tres salidas: bañera-ducha teléfono-rociador con posiciones de stop intermedias _ completo de partes internas

IN
3/4"

OUT
1/2"



Parti esterne
 Outer parts / Fertigset / Parties externes / Partes externas

PR47LB201

CRL
 IX, CRB, BLX, BRX, C03, C04, F31, F34
 DOR, GOX, CHX, F32, F33, F36, F37



Parti da incasso
 Built-in parts / UP-teile / Parties internes / Partes internas

PM00706



Miscelatore completo
 Complete mixer / Vollständige Mischer / Mitigeur complete / Mezclador completo

PR47LA201

CRL
 IX, CRB, BLX, BRX, C03, C04, F31, F34
 DOR, GOX, CHX, F32, F33, F36, F37

Accessori / Accessories / Zubehör / Accessoires / Accesorios

Ricambi / Spare parts / Ersatzteile / Pièces de rechange / Recambios



RCMB829
 pag. 1235



RCMB909
 pag. 1240



RCMB954
 pag. 1241



RCMBA013
 pag. 1244

 <div data-bbox="199 553 312 614"> <p>IN 1/2" F OUT 1/2" F</p> </div>	<p>Deviatore ad incasso <i>Built-in diverter UP-Umstellung Inverseur à encastrer Desviador empotrado</i></p> <p>tre uscite: vasca-doccetta-soffione e posizione di stop _ completo di parti interne <i>_ three ways: bath-hand shower-head shower and stop position _ with inner parts _ drei Abgänge: Wanne-Brause-Wandanschlußbogen und Stopstellung _ mit UP-Teilen _ trois sorties: baignoire-douchette-bras de douche et stop _ avec parties internes _ tres salidas: bañera-duchita-pomo ducha y stop _ completo de partes internas</i></p>	
--	---	---

	<p>Parti esterne <i>Outer parts / Fertigset / Parties externes / Partes externas</i></p>	<p>PR52LB221 CRL IX, CRB, BLX, BRX, C03, C04, F31, F34 DOR, GOX, CHX, F32, F33, F36, F37</p>
---	--	--

	<p>Parti da incasso <i>Built-in parts / UP-teile / Parties internes / Partes internas</i></p>	<p>PM00707</p>
--	---	-----------------------

<p>Miscelatore completo <i>Complete mixer / Vollständige Mischer / Mitigeur complete / Mezclador completo</i></p>	<p>PR52LA221 CRL IX, CRB, BLX, BRX, C03, C04, F31, F34 DOR, GOX, CHX, F32, F33, F36, F37</p>
---	--

Accessori / Accessories / Zubehör / Accessoires / Accesorios

Ricambi / Spare parts / Ersatzteile / Pièces de rechange / Recambios

 <p>RCMB877 pag. 1237</p>	 <p>RCMB898 pag. 1239</p>	 <p>RCMBA105 pag. 1246</p>	 <p>RCMBA129 pag. 1248</p>	 <p>RCMBA146 pag. 1249</p>
--	--	---	---	---

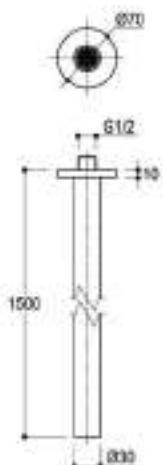
 <div data-bbox="88 549 204 604"> </div>	<p>Bocca di erogazione da soffitto per lavabo <i>Washbasin ceiling mounted spout Waschbecken Deckenauslauf Bec de lavabo suspendu Caño salida a techo por lavabo</i></p> <hr/> <p>L=1500mm - L=1500mm - L=1500mm - L=1500mm - L=1500mm</p>	
--	--	---

E0BA0185H03

CRL

IX, CRB, BLX, BRX, C03, C04, F31, F34
 DOR, GOX, CHX, F32, F33, F36, F37

Accessori / Accessories / Zubehör / Accessoires / Accesorios

Ricambi / Spare parts / Ersatzteile / Pièces de rechange / Recambios



RCMB507
 pag. 1221

 <div data-bbox="88 1439 204 1495"> </div>	<p>Bocca di erogazione da soffitto per lavabo <i>Washbasin ceiling mounted spout Waschbecken Deckenauslauf Bec de lavabo suspendu Caño salida a techo por lavabo</i></p> <hr/> <p>Lunghezza (L) personalizzabile su richiesta: minimo 500mm, massimo 1600mm - Customizable length (L) on application, min 500mm max 1600mm - Länge (L) auf Wunsch min 500mm max 1600mm - Longueur (L) personnalisable sur demande min 500mm max 1600mm - Largo (L) personalizable sobre solicitud min 500 max 1600mm</p>	
--	--	---

E0BA0185H--

CRL

IX, CRB, BLX, BRX, C03, C04, F31, F34
 DOR, GOX, CHX, F32, F33, F36, F37

Accessori / Accessories / Zubehör / Accessoires / Accesorios

Ricambi / Spare parts / Ersatzteile / Pièces de rechange / Recambios



RCMB507
 pag. 1221



Canna quadra da piano per lavabo
 Square washbasin standing spout
 Quadratischer Auslauf für Waschtisch Montage
 Bec carré pour lavabo sur plan
 Caño cuadrado de encimera para lavabo

L=230mm, H=228mm supporto e kit di fissaggio per
·Diametro35 Impronte-PR51· AP201 ·Diametro35 S-PR52· AE201
 L=230mm, H=228mm support and fixing kit for
 ·Diametro35 Impronte-PR51· AP201 ·Diametro35 S-PR52· AE201
 L=230mm, H=228mm Befestigung und Montageset für
 ·Diametro35 Impronte-PR51· AP201 ·Diametro35 S-PR52· AE201
 L=230mm, H=228mm support et kit de fixation pour
 ·Diametro35 Impronte-PR51· AP201 ·Diametro35 S-PR52· AE201
 L=230mm, H=228mm soporte y kit de fijación para
 ·Diametro35 Impronte-PR51· AP201 ·Diametro35 S-PR52· AE201

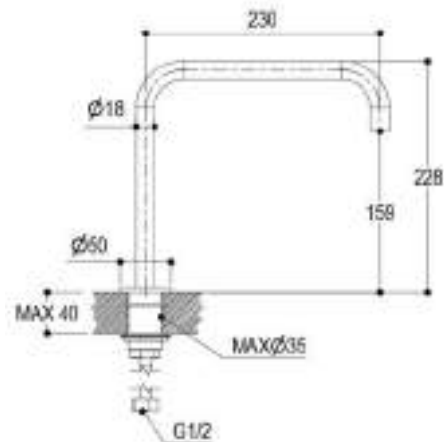

PR52CM201

CRL
 IX, CRB, BLX, BRX, C03, C04, F31, F34
 DOR, GOX, CHX, F32, F33, F36, F37

Accessori / Accessories / Zubehör / Accessoires / Accesorios

Ricambi / Spare parts / Ersatzteile / Pièces de rechange / Recambios



RCMB307 pag. 1218
 RCMA124 pag. 1247



Canna quadra da piano per lavabo
 Square washbasin standing spout
 Quadratischer Auslauf für Waschtisch Montage
 Bec carré pour lavabo sur plan
 Caño cuadrado de encimera para lavabo

L=230mm, H=328mm supporto e kit di fissaggio
 L=230mm, H=328mm support and fixing kit
 L=230mm, H=328mm Befestigung und Montageset
 L=230mm, H=328mm support et kit de fixation
 L=230mm, H=328mm soporte y kit de fijación

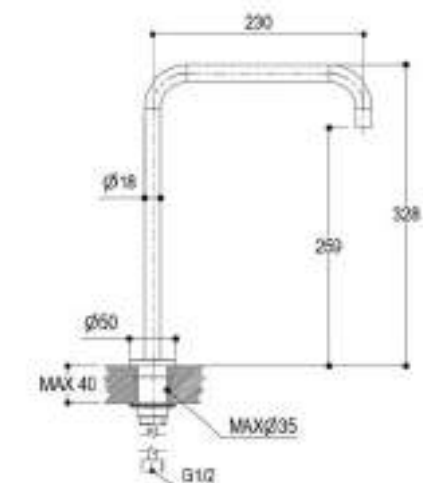

PR52CM202

CRL
 IX, CRB, BLX, BRX, C03, C04, F31, F34
 DOR, GOX, CHX, F32, F33, F36, F37

Accessori / Accessories / Zubehör / Accessoires / Accesorios

Ricambi / Spare parts / Ersatzteile / Pièces de rechange / Recambios



RCMB307 pag. 1218
 RCMA124 pag. 1247



Canna cigno da piano per lavabo
*Washbasin standing spout
 Schwanen Auslauf für Waschtisch Montage
 bec col de cygne pour lavabo sur plan
 Caño cisne de encimera para lavabo*

**L=230mm, H=293mm_ supporto e kit di fissaggio per
 ·Diametro35_Impronte-PR51· AP202 ·Diametro35_S·PR52· AE202**
*L=230mm, H=293mm_ support and fixing kit _for
 ·Diametro35_Impronte-PR51· AP202 ·Diametro35_S·PR52· AE202
 L=230mm, H=293mm_ Befestigung und Montageset für
 ·Diametro35_Impronte-PR51· AP202 ·Diametro35_S·PR52· AE202
 L=230mm, H=293mm_ support et kit de fixation _pour
 ·Diametro35_Impronte-PR51· AP202 ·Diametro35_S·PR52· AE202
 L=230mm, H=293mm_ soporte y kit de fijación _para
 ·Diametro35_Impronte-PR51· AP202 ·Diametro35_S·PR52· AE202*

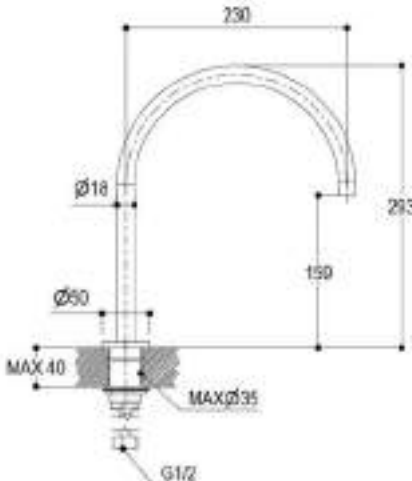

PR52CM211

CRL

IX, CRB, BLX, BRX, C03, C04, F31, F34
 DOR, GOX, CHX, F32, F33, F36, F37

Accessori / Accessories / Zubehör / Accessoires / Accesorios

Ricambi / Spare parts / Ersatzteile / Pièces de rechange / Recambios



RCMB307
pag. 1218

RCMBA124
pag. 1247



Canna cigno da piano per lavabo
*Washbasin standing spout
 Schwanen Auslauf für Waschtisch Montage
 bec col de cygne pour lavabo sur plan
 Caño cisne de encimera para lavabo*

L=230mm, H=393mm_ supporto e kit di fissaggio
*L=230mm, H=393mm_ support and fixing kit
 L=230mm, H=393mm_ Befestigung und Montageset
 L=230mm, H=393mm_ support et kit de fixation
 L=230mm, H=393mm_ soporte y kit de fijación*



PR52CM212

CRL

IX, CRB, BLX, BRX, C03, C04, F31, F34
 DOR, GOX, CHX, F32, F33, F36, F37

Accessori / Accessories / Zubehör / Accessoires / Accesorios

Ricambi / Spare parts / Ersatzteile / Pièces de rechange / Recambios



RCMB307
pag. 1218



RCMBA124
pag. 1247

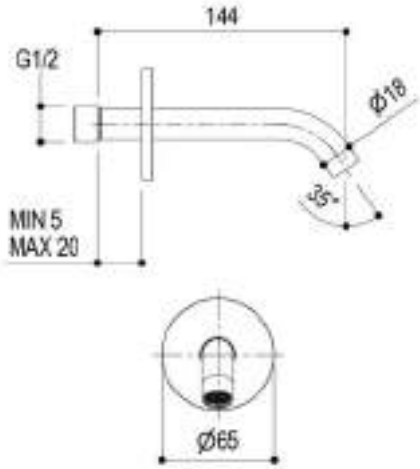

Bocca di erogazione da muro per lavabo
Wall spout for washbasin
Wandauslauf für Waschbecken
Bec verseur à mur pour lavabo
Caño a muro para lavabo

L=144mm
 - L=144mm
 - L=144mm
 - L=144mm
 - L=144mm



PR52CA201 **CRL**
 IX, CRB, BLX, BRX, C03, C04, F31, F34
 DOR, GOX, CHX, F32, F33, F36, F37

Accessori / Accessories / Zubehör / Accessoires / Accesorios

Ricambi / Spare parts / Ersatzteile / Pièces de rechange / Recambios





RCMBA124 pag. 1247 RCMBA126H1 pag. 1247 RCMBA133 pag. 1248

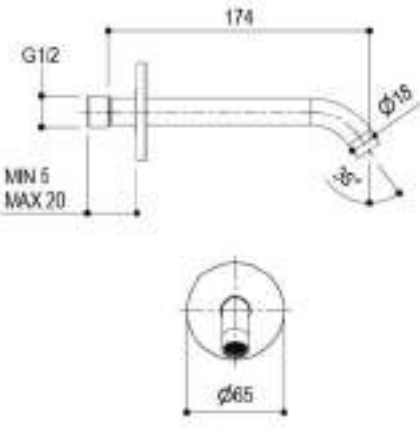

Bocca di erogazione da muro per lavabo
Wall spout for washbasin
Wandauslauf für Waschbecken
Bec verseur à mur pour lavabo
Caño a muro para lavabo

L=174mm
 - L=174mm
 - L=174mm
 - L=174mm
 - L=174mm



PR52CA203 **CRL**
 IX, CRB, BLX, BRX, C03, C04, F31, F34
 DOR, GOX, CHX, F32, F33, F36, F37

Accessori / Accessories / Zubehör / Accessoires / Accesorios

Ricambi / Spare parts / Ersatzteile / Pièces de rechange / Recambios



RCMBA124 pag. 1247 RCMBA126H3 pag. 1247 RCMBA133 pag. 1248



Bocca di erogazione da muro per lavabo
Wall spout for washbasin
Wandauslauf für Waschbecken
Bec verseur à mur pour lavabo
Caño a muro para lavabo

L=204mm
 - L=204mm
 - L=204mm
 - L=204mm
 - L=204mm

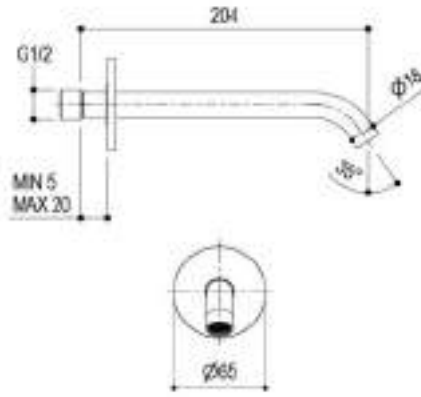

PR52CA202

CRL

IX, CRB, BLX, BRX, C03, C04, F31, F34

DOR, GOX, CHX, F32, F33, F36, F37

Accessori / Accessories / Zubehör / Accessoires / Accesorios

Ricambi / Spare parts / Ersatzteile / Pièces de rechange / Recambios



RCMBA124
pag. 1247

RCMBA126H2
pag. 1247

RCMBA133
pag. 1248



Canna quadra da piano per bidet
Countertop square bidet spout
Quadratischer Wandauslauf für Bidet
Bec carré pour bidet sur plan
Caño cuadrado de encimera para bidet

He=54mm, L=124mm supporto e kit di fissaggio per Diametro35 Impronte-PR51·BP201·Diametro35 S-PR52·BE201
 He=54mm, L=124mm _ support and fixing kit _ for
 ·Diametro35_Impronte-PR51·BP201·Diametro35_S-PR52·BE201
 He=54mm, L=124mm _ Befestigung und Montageset _ für
 ·Diametro35_Impronte-PR51·BP201·Diametro35_S-PR52·BE201
 He=54mm, L=124mm _ support et kit de fixation _ pour
 ·Diametro35_Impronte-PR51·BP201·Diametro35_S-PR52·BE201
 He=54mm, L=124mm _ soporte y kit de fijación _ para
 ·Diametro35_Impronte-PR51·BP201·Diametro35_S-PR52·BE201



PR52CR201

CRL

IX, CRB, BLX, BRX, C03, C04, F31, F34

DOR, GOX, CHX, F32, F33, F36, F37

Accessori / Accessories / Zubehör / Accessoires / Accesorios

Ricambi / Spare parts / Ersatzteile / Pièces de rechange / Recambios



RCMB307
pag. 1218

RCMB617
pag. 1226

RCMBA162
pag. 1250



Canna cigno da piano per bidet
Countertop bidet spout
Schwänen Auslauf für Bidet
Bec col de cygne pour bidet sur plan
Caño cisne de encimera para bidet

He=54mm, L=122mm supporto e kit di fissaggio per
·Diametro35 Impronte·PR51·BP202·Diametro35_S·PR52·BE202
He=54mm, L=122mm support and fixing kit for
·Diametro35 Impronte·PR51·BP202·Diametro35_S·PR52·BE202
He=54mm, L=122mm Befestigung und Montageset für
·Diametro35 Impronte·PR51·BP202·Diametro35_S·PR52·BE202
He=54mm, L=122mm support et kit de fixation pour
·Diametro35 Impronte·PR51·BP202·Diametro35_S·PR52·BE202
He=54mm, L=122mm soporte y kit de fijación para
·Diametro35 Impronte·PR51·BP202·Diametro35_S·PR52·BE202







PR52CR211 **CRL**
IX, CRB, BLX, BRX, C03, C04, F31, F34
DOR, GOX, CHX, F32, F33, F36, F37

Accessori / Accessories / Zubehör / Accessoires / Accesorios

Ricambi / Spare parts / Ersatzteile / Pièces de rechange / Recambios





RCMB307 pag. 1218 RCMB617 pag. 1226 RCMBA162 pag. 1250

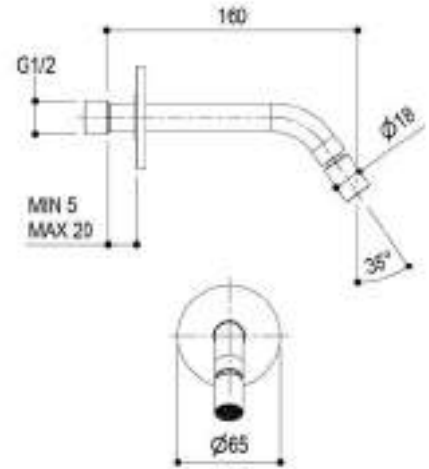

Bocca di erogazione da muro per bidet
Wall spout for bidet
Wandauslauf für Bidet
Bec seuseur à mur pour bidet
Caño a muro para bidet

L=160mm
 _ L=160mm
 _ L=160mm
 _ L=160mm
 _ L=160mm



PR52CP201 **CRL**
IX, CRB, BLX, BRX, C03, C04, F31, F34
DOR, GOX, CHX, F32, F33, F36, F37

Accessori / Accessories / Zubehör / Accessoires / Accesorios

Ricambi / Spare parts / Ersatzteile / Pièces de rechange / Recambios





RCMB617 pag. 1226 RCMBA127H1 pag. 1247 RCMBA133 pag. 1248 RCMBA162 pag. 1250

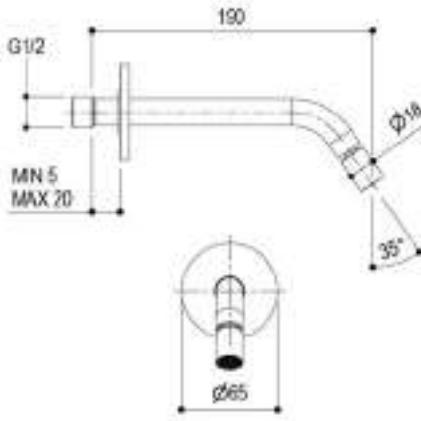

Bocca di erogazione da muro per bidet
Wall spout for bidet
Wandauslauf für Bidet
Bec verseur à mur pour bidet
Caño a muro para bidet

L=190mm
 - L=190mm
 - L=190mm
 - L=190mm
 - L=190mm





PR52CP203

CRL
IX, CRB, BLX, BRX, C03, C04, F31, F34
DOR, GOX, CHX, F32, F33, F36, F37

Accessori / Accessories / Zubehör / Accessoires / Accesorios

Ricambi / Spare parts / Ersatzteile / Pièces de rechange / Recambios





Bocca di erogazione da muro per bidet
Wall spout for bidet
Wandauslauf für Bidet
Bec verseur à mur pour bidet
Caño a muro para bidet

L=220mm
 - L=220mm
 - L=220mm
 - L=220mm
 - L=220mm

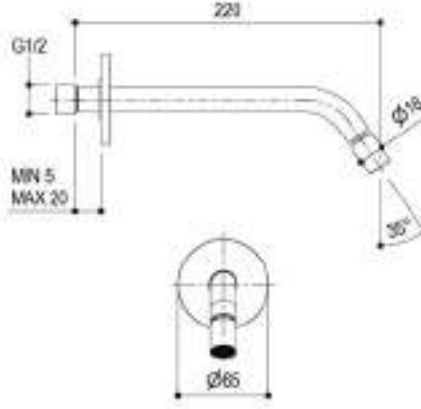



PR52CP202

CRL
IX, CRB, BLX, BRX, C03, C04, F31, F34
DOR, GOX, CHX, F32, F33, F36, F37

Accessori / Accessories / Zubehör / Accessoires / Accesorios

Ricambi / Spare parts / Ersatzteile / Pièces de rechange / Recambios





Bocca di erogazione da muro per vasca
Wall spout for bathtub
Wandauslauf für Badewanne
Bec verseur à mur pour baignoire
Caño a muro para bañera

L=200mm _ piastra esterna
 _ L=200mm _ external plate
 _ L=200mm _ Montageplatte
 _ L=200mm _ plaque externe
 _ L=200mm _ plancha externa

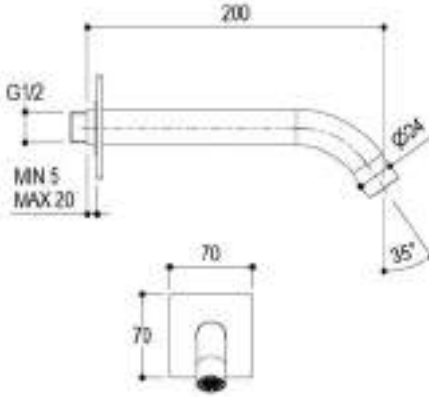

IN
1/2" M

PR52CC101 **CRL**
 IX, CRB, BLX, BRX, C03, C04, F31, F34
 DOR, GOX, CHX, F32, F33, F36, F37

Accessori / Accessories / Zubehör / Accessoires / Accesorios

Ricambi / Spare parts / Ersatzteile / Pièces de rechange / Recambios



RCMB552 pag. 1223 RCMB740 pag. 1231 RCMB139 pag. 1249



Bocca di erogazione da muro per vasca
Wall spout for bathtub
Wandauslauf für Badewanne
Bec verseur à mur pour baignoire
Caño a muro para bañera

L=200mm
 _ L=200mm
 _ L=200mm
 _ L=200mm
 _ L=200mm

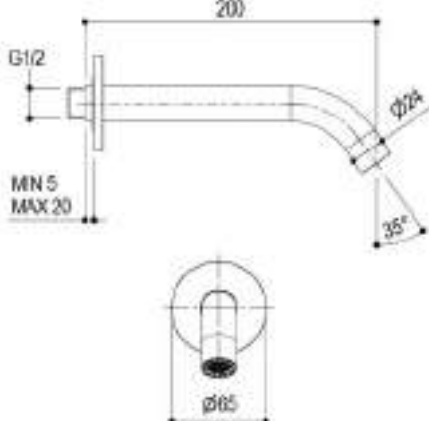

IN
1/2" M

PR52CC201 **CRL**
 IX, CRB, BLX, BRX, C03, C04, F31, F34
 DOR, GOX, CHX, F32, F33, F36, F37

Accessori / Accessories / Zubehör / Accessoires / Accesorios

Ricambi / Spare parts / Ersatzteile / Pièces de rechange / Recambios



RCMB552 pag. 1223 RCMB740 pag. 1231 RCMB158 pag. 1250



Bocca di erogazione quadra per gruppo bordo vasca
Square spout for deck mounted bath group
Quadratischer Standauslauf für Wannrandbatterie
Bec verseur carré pour baignoire batterie
Caño cuadrado para grupo borde bañera

H=138mm, L=150mm supporto e kit di fissaggio per
·Diametro35 Impronte-PR51· ES101-ES201 ·Diametro35 S-PR52·
EG101-EG201 ·Diametro35 Cross-PR53· EG101-EG201
·Diametro35 Elegance-PR54· EG101-EG201
H=138mm, L=150mm support and fixing kit for
·Diametro35 Impronte-PR51· ES101-ES201 ·Diametro35 S-PR52·
EG101-EG201 ·Diametro35 Cross-PR53· EG101-EG201
·Diametro35 Elegance-PR54· EG101-EG201
H=138mm, L=150mm Befestigung und Montageset für
·Diametro35 Impronte-PR51· ES101-ES201 ·Diametro35 S-PR52·
EG101-EG201 ·Diametro35 Cross-PR53· EG101-EG201
·Diametro35 Elegance-PR54· EG101-EG201
H=138mm, L=150mm support et kit de fixation pour
·Diametro35 Impronte-PR51· ES101-ES201 ·Diametro35 S-PR52·
EG101-EG201 ·Diametro35 Cross-PR53· EG101-EG201
·Diametro35 Elegance-PR54· EG101-EG201
H=138mm, L=150mm soporte y kit de fijación para
·Diametro35 Impronte-PR51· ES101-ES201 ·Diametro35 S-PR52·
EG101-EG201 ·Diametro35 Cross-PR53· EG101-EG201
·Diametro35 Elegance-PR54· EG101-EG201

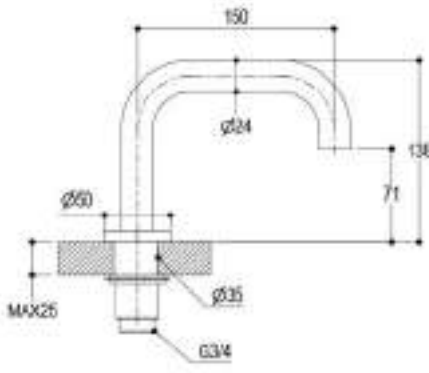

PR52CN201

CRL
IX, CRB, BLX, BRX, C03, C04, F31, F34
DOR, GOX, CHX, F32, F33, F36, F37

Accessori / Accessories / Zubehör / Accessoires / Accesorios

Ricambi / Spare parts / Ersatzteile / Pièces de rechange / Recambios

 RCMB552
 pag. 1223



Bocca di erogazione cigno per gruppo bordo vasca
spout for deck mounted bath group
Schwänen Standauslauf für Wannrandbatterie
Bec verseur col de cygne pour baignoire batterie
Caño cisne para grupo borde bañera

H=173mm, L=150mm supporto e kit di fissaggio per
·Diametro35 Impronte-PR51· ES102-ES202 ·Diametro35 S-PR52·
EG102-EG202 ·Diametro35 Cross-PR53· EG102-EG202
·Diametro35 Elegance-PR54· EG102-EG202
H=173mm, L=150mm support and fixing kit for
·Diametro35 Impronte-PR51· ES102-ES202 ·Diametro35 S-PR52·
EG102-EG202 ·Diametro35 Cross-PR53· EG102-EG202
·Diametro35 Elegance-PR54· EG102-EG202
H=173mm, L=150mm Befestigung und Montageset für
·Diametro35 Impronte-PR51· ES102-ES202 ·Diametro35 S-PR52·
EG102-EG202 ·Diametro35 Cross-PR53· EG102-EG202
·Diametro35 Elegance-PR54· EG102-EG202
H=173mm, L=150mm support et kit de fixation pour
·Diametro35 Impronte-PR51· ES102-ES202 ·Diametro35 S-PR52·
EG102-EG202 ·Diametro35 Cross-PR53· EG102-EG202
·Diametro35 Elegance-PR54· EG102-EG202
H=173mm, L=150mm soporte y kit de fijación para
·Diametro35 Impronte-PR51· ES102-ES202 ·Diametro35 S-PR52·
EG102-EG202 ·Diametro35 Cross-PR53· EG102-EG202
·Diametro35 Elegance-PR54· EG102-EG202

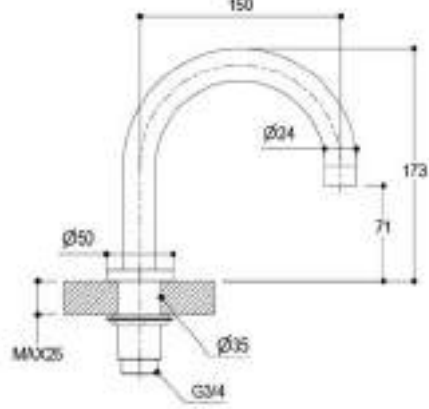





PR52CN211

CRL
IX, CRB, BLX, BRX, C03, C04, F31, F34
DOR, GOX, CHX, F32, F33, F36, F37

Accessori / Accessories / Zubehör / Accessoires / Accesorios

Ricambi / Spare parts / Ersatzteile / Pièces de rechange / Recambios

 RCMB552
 pag. 1223

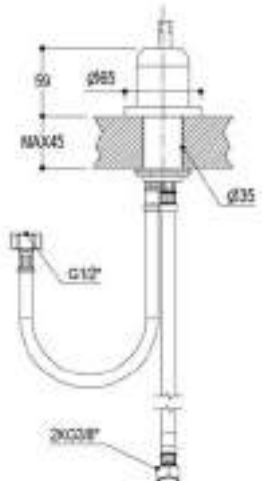
    	<p>Miscelatore monocomando <i>Single lever mixer</i> <i>Einhandmischer</i> <i>Mitigeur monocommande</i> <i>Mezclador monomando</i></p> <hr/> <p>senza comando [PR51MC10x] _ without handle [PR51MC10x] _ ohne Griff [PR51MC10x] _ sans commande [PR51MC10x] _ sin mando [PR51MC10x]</p>	
--	---	---

Miscelatore completo (senza comando)
Complete mixer (without handle) / Vollständige Mischer (ohne Griff) / Mitigeur complete (sans commande) / Mezclador completo (sin mando)

PR51AS201

CRL
IX, CRB, BLX, BRX, C03, C04, F31, F34
DOR, GOX, CHX, F32, F33, F36, F37

+ Comando / Handles / Griff / Commande / Mando

Comando PRISMA
Handle PRISMA / Griff PRISMA / Commande PRISMA / Mando PRISMA



PR51MC101

CRL
IX, CRB, BLX, BRX, C03, C04, F31, F34
DOR, GOX, CHX, F32, F33, F36, F37

Comando TRATTO
Handle TRATTO / Griff TRATTO / Commande TRATTO / Mando TRATTO



PR51MC102

CRL
IX, CRB, BLX, BRX, C03, C04, F31, F34
DOR, GOX, CHX, F32, F33, F36, F37

Comando RIGO
Handle RIGO / Griff RIGO / Commande RIGO / Mando RIGO



PR51MC103

CRL
IX, CRB, BLX, BRX, C03, C04, F31, F34
DOR, GOX, CHX, F32, F33, F36, F37

Comando PUNTO
Handle PUNTO / Griff PUNTO / Commande PUNTO / Mando PUNTO



PR51MC104

CRL
IX, CRB, BLX, BRX, C03, C04, F31, F34
DOR, GOX, CHX, F32, F33, F36, F37

Accessori / Accessories / Zubehör / Accessoires / Accesorios

Ricambi / Spare parts / Ersatzteile / Pièces de rechange / Recambios



RCMB015
 pag. 1213



RCMB021
 pag. 1214



RCMB125
 pag. 1217



RCMB307
 pag. 1218



RCMB742
 pag. 1231

Miscelatore e comando venduti separatamente

Mixer and handle sold separately / Mischer und Griff separat verkauf / Mitigeur et manette vendus séparément / Mezclador y mando vendidos separatamente



Gruppo due fori per lavabo
Two holes basin group
Zweiloch Waschtischnatterie
Groupe deux trous pour lavabo
Grupo mezclador con dos agujeros para lavabo

_ comandi caldo/freddo _ due uscite _ bocca di erogazione venduta a parte _ senza comandi [PR51MB01x]
_ hot/cold control handles _ two outlets _ spout separately sold _ without handles [PR51MB01x]
_ warm/kalt Griff _ Zwei Abgänge _ separat Verkauf des Auslaufs _ ohne Griffe [PR51MB01x]
_ chaude/froide leviers _ deux sorties _ bec verseur vendus séparément _ sans commandes [PR51MB01x]
_ mandos caliente/frío _ dos salidas _ caño vendido separadamente _ sin mandos [PR51MB01x]

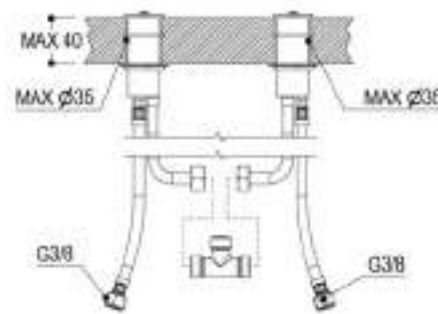

IN
3/8"





OUT
1/2"



Miscelatore completo (senza comando)
Complete mixer (without handle) / Vollständige Mischer (ohne Griff) / Mitigeur complete (sans commande) / Mezclador completo (sin mando)



PR51AS221 **CRL**
IX, CRB, BLX, BRX, C03, C04, F31, F34
DOR, GOX, CHX, F32, F33, F36, F37

+ Comando / Handles / Griff / Commande / Mando

<p>Comandi PRISMA <i>Handles PRISMA / Griffe PRISMA / Commandes PRISMA / Mandos PRISMA</i></p>  <p>PR51MB011</p> <hr/> <p>CRL IX, CRB, BLX, BRX, C03, C04, F31, F34 DOR, GOX, CHX, F32, F33, F36, F37</p>	<p>Comandi TRATTO <i>Handles TRATTO / Griffe TRATTO / Commandes TRATTO / Mandos TRATTO</i></p>  <p>PR51MB012</p> <hr/> <p>CRL IX, CRB, BLX, BRX, C03, C04, F31, F34 DOR, GOX, CHX, F32, F33, F36, F37</p>	<p>Comandi RIGO <i>Handles RIGO / Griffe RIGO / Commandes RIGO / Mandos RIGO</i></p>  <p>PR51MB013</p> <hr/> <p>CRL IX, CRB, BLX, BRX, C03, C04, F31, F34 DOR, GOX, CHX, F32, F33, F36, F37</p>	<p>Comandi PUNTO <i>Handles PUNTO / Griffe PUNTO / Commandes PUNTO / Mandos PUNTO</i></p>  <p>PR51MB014</p> <hr/> <p>CRL IX, CRB, BLX, BRX, C03, C04, F31, F34 DOR, GOX, CHX, F32, F33, F36, F37</p>
---	---	--	--

Accessori / Accessories / Zubehör / Accessoires / Accesorios

Ricambi / Spare parts / Ersatzteile / Pièces de rechange / Recambios

 <p>RCMB068 pag. 1216</p>	 <p>RCMB972 pag. 1242</p>	 <p>RCMBA069 pag. 1245</p>	 <p>RCMBA135 pag. 1248</p>
---	---	--	--

Miscelatore e comandi venduti separatamente
Mixer and handles sold separately / Mischer und Griffe separat verkauft / Mélangeur et manettes vendus séparément / Mezclador y mandos vendidos separadamente

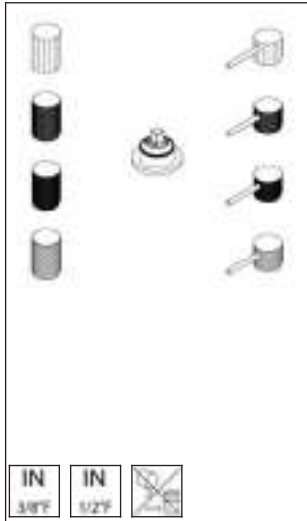

Miscelatore monocomando

Single lever mixer
Einhandmischer
Mitigeur monocommande
Mezclador monomando

- senza comando [PR51MA00x] o [PR51MA10x]
- without handle [PR51MA00x] or [PR51MA10x]
- ohne Griff [PR51MA00x] oder [PR51MA10x]
- sans commande [PR51MA00x] ou [PR51MA10x]
- sin mando [PR51MA00x] o [PR51MA10x]

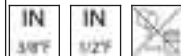
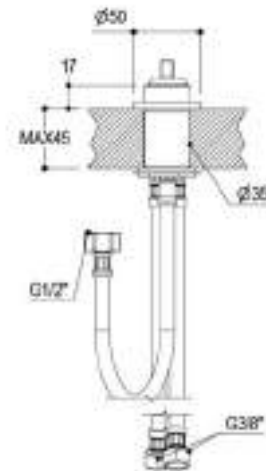

Miscelatore completo (senza comando)
Complete mixer (without handle) / Vollständige
Mischer (ohne Griff) / Mitigeur complete (sans
commande) / Mezclador completo (sin mando)

PR51AS211

CRL
IX, CRB, BLX, BRX, C03, C04, F31, F34
DOR, GOX, CHX, F32, F33, F36, F37

+ Comando / Handles / Griff / Commande / Mando

Comando PRISMA
Handle PRISMA / Griff PRISMA /
Commande PRISMA / Mando
PRISMA



PR51MA001 PR51MA101

CRL
IX, CRB, BLX, BRX,
C03, C04, F31, F34
DOR, GOX, CHX, F32,
F33, F36, F37

Comando TRATTO
Handle TRATTO / Griff TRATTO /
Commande TRATTO / Mando
TRATTO



PR51MA002 PR51MA102

CRL
IX, CRB, BLX, BRX,
C03, C04, F31, F34
DOR, GOX, CHX, F32,
F33, F36, F37

Comando RIGO
Handle RIGO / Griff RIGO /
Commande RIGO / Mando RIGO



PR51MA003 PR51MA103

CRL
IX, CRB, BLX, BRX,
C03, C04, F31, F34
DOR, GOX, CHX, F32,
F33, F36, F37

Comando PUNTO
Handle PUNTO / Griff PUNTO /
Commande PUNTO / Mando
PUNTO



PR51MA004 PR51MA104

CRL
IX, CRB, BLX, BRX,
C03, C04, F31, F34
DOR, GOX, CHX, F32,
F33, F36, F37

Accessori / Accessories / Zubehör / Accessoires / Accesorios

Ricambi / Spare parts / Ersatzteile / Pièces de rechange / Recambios



RCMB021 pag. 1214
RCMB307 pag. 1218
RCMB435 pag. 1220
RCMBA130 pag. 1248

Miscelatore e comando venduti separatamente

Mixer and handle sold separately / Mischer und Griff separat verkauf / Mitigeur et manette vendus séparément / Mezclador y mando vendidos separatamente

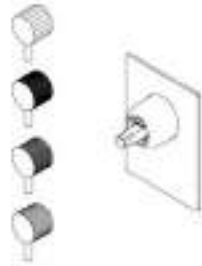

Miscelatore monocomando ad incasso per doccia/lavabo
Built-in single lever shower/basin mixer
UP-Einhandmischer für Dusche/Waschtisch
Mitigeur monocommande à encastrer pour douche/lavabo
Mezclador monomando empotrado para ducha/lavabo

_ piastra esterna _ una uscita _ completo di parti interne _ senza comando [PR51MC10x]
external plate _ one way _ complete of inner parts _ without handle [PR51MC10x]
Montageplatte _ Ein Abgang _ komplett mit UP-Teilen _ ohne Griff [PR51MC10x]
_ plaque externe _ une sortie _ complet avec parties internes _ sans commande [PR51MC10x]
_ plancha externa _ una salida _ completo de partes internas _ sin mando [PR51MC10x]

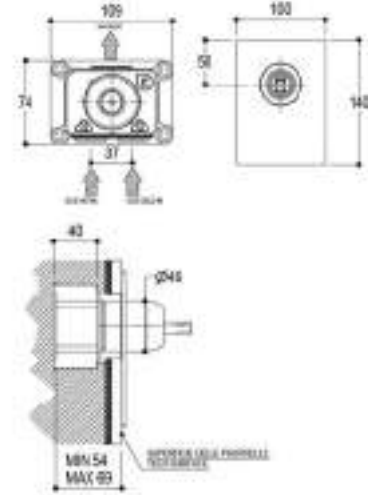

IN
1/2"

OUT
1/2"





Parti esterne
Outer parts / Fertigset / Parties externes / Partes externas

PR51FN101

CRL
IX, CRB, BLX, BRX, C03, C04, F31, F34
DOR, GOX, CHX, F32, F33, F36, F37



Parti da incasso
Built-in parts / UP-teile / Parties internes / Partes internas





E0BA0143

Miscelatore completo (senza comando)
Complete mixer (without handle) / Vollständige Mischer (ohne Griff) / Mitigeur complete (sans commande) / Mezclador completo (sin mando)

PR51FM101

CRL
IX, CRB, BLX, BRX, C03, C04, F31, F34
DOR, GOX, CHX, F32, F33, F36, F37

+ Comando / Handles / Griff / Commande / Mando

<p>Comando PRISMA <i>Handle PRISMA / Griff PRISMA / Commande PRISMA / Mando PRISMA</i></p>  <p>PR51MC101</p> <p>CRL IX, CRB, BLX, BRX, C03, C04, F31, F34 DOR, GOX, CHX, F32, F33, F36, F37</p>	<p>Comando TRATTO <i>Handle TRATTO / Griff TRATTO / Commande TRATTO / Mando TRATTO</i></p>  <p>PR51MC102</p> <p>CRL IX, CRB, BLX, BRX, C03, C04, F31, F34 DOR, GOX, CHX, F32, F33, F36, F37</p>	<p>Comando RIGO <i>Handle RIGO / Griff RIGO / Commande RIGO / Mando RIGO</i></p>  <p>PR51MC103</p> <p>CRL IX, CRB, BLX, BRX, C03, C04, F31, F34 DOR, GOX, CHX, F32, F33, F36, F37</p>	<p>Comando PUNTO <i>Handle PUNTO / Griff PUNTO / Commande PUNTO / Mando PUNTO</i></p>  <p>PR51MC104</p> <p>CRL IX, CRB, BLX, BRX, C03, C04, F31, F34 DOR, GOX, CHX, F32, F33, F36, F37</p>
--	--	---	---

Accessori / Accessories / Zubehör / Accessoires / Accesorios

Prolunghe / Extensions / Verlängerungen / Rallonges / Prolongadoras & Ricambi / Spare parts / Ersatzteile / Pièces de rechange / Recambios

 <p>+25mm RCMB054H1 pag. 1202</p>	 <p>+40mm RCMB054H2 pag. 1202</p>	 <p>RCMB015 pag. 1213</p>	 <p>RCMB742 pag. 1231</p>	 <p>RCMBA131 pag. 1248</p>
---	---	--	--	---

Miscelatore e comando venduti separatamente
Mixer and handle sold separately / Mischer und Griff separat verkauft / Mitigeur et manette vendus séparément / Mezclador y mando vendidos separatamente

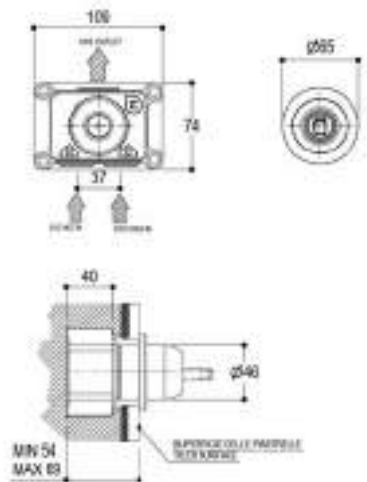



 <div style="display: flex; justify-content: space-around; margin-top: 10px;"> <div style="border: 1px solid black; padding: 2px; font-size: 8px;">IN 1/2"</div> <div style="border: 1px solid black; padding: 2px; font-size: 8px;">OUT 1/2"</div> <div style="border: 1px solid black; padding: 2px; font-size: 8px;">X</div> </div>	<p>Miscelatore monocomando ad incasso per doccia/lavabo <i>Built-in single lever shower/basin mixer</i> <i>UP-Einhandmischer für Dusche/Waschtisch</i> <i>Mitigeur monocommande à encastrer pour douche/lavabo</i> <i>Mezclador monomando empotrado para ducha/lavabo</i></p> <hr/> <p>una uscita _ completo di parti interne _ senza comando [PR51MC10x] _ one way _ complete of inner parts _ without handle [PR51MC10x] _ Ein Abgang _ komplett mit UP-Teilen _ ohne Griff [PR51MC10x] _ une sortie _ complet avec parties internes _ sans commande [PR51MC10x] _ una salida _ completo de partes internas _ sin mando [PR51MC10x]</p>	
---	---	---

	<p>Parti esterne <i>Outer parts / Fertigset / Parties externes / Partes externas</i></p>	<p>PR51FN201 CRL IX, CRB, BLX, BRX, C03, C04, F31, F34 DOR, GOX, CHX, F32, F33, F36, F37</p>
---	--	--

	<p>Parti da incasso <i>Built-in parts / UP-teile / Parties internes / Partes internas</i></p>	<p>E0BA0143</p>
--	---	------------------------

<p>Miscelatore completo (senza comando) <i>Complete mixer (without handle) / Vollständige Mischer (ohne Griff) / Mitigeur complete (sans commande) / Mezclador completo (sin mando)</i></p>	<p>PR51FM201 CRL IX, CRB, BLX, BRX, C03, C04, F31, F34 DOR, GOX, CHX, F32, F33, F36, F37</p>
---	--

+ Comando / Handles / Griff / Commande / Mando

<p>Comando PRISMA <i>Handle PRISMA / Griff PRISMA / Commande PRISMA / Mando PRISMA</i></p>  <p>PR51MC101</p> <p>CRL IX, CRB, BLX, BRX, C03, C04, F31, F34 DOR, GOX, CHX, F32, F33, F36, F37</p>	<p>Comando TRATTO <i>Handle TRATTO / Griff TRATTO / Commande TRATTO / Mando TRATTO</i></p>  <p>PR51MC102</p> <p>CRL IX, CRB, BLX, BRX, C03, C04, F31, F34 DOR, GOX, CHX, F32, F33, F36, F37</p>	<p>Comando RIGO <i>Handle RIGO / Griff RIGO / Commande RIGO / Mando RIGO</i></p>  <p>PR51MC103</p> <p>CRL IX, CRB, BLX, BRX, C03, C04, F31, F34 DOR, GOX, CHX, F32, F33, F36, F37</p>	<p>Comando PUNTO <i>Handle PUNTO / Griff PUNTO / Commande PUNTO / Mando PUNTO</i></p>  <p>PR51MC104</p> <p>CRL IX, CRB, BLX, BRX, C03, C04, F31, F34 DOR, GOX, CHX, F32, F33, F36, F37</p>
--	--	--	---

Accessori / Accessories / Zubehör / Accessoires / Accesorios

Prolunghe / Extensions / Verlängerungen / Rallonges / Prolongadoras & Ricambi / Spare parts / Ersatzteile / Pièces de rechange / Recambios

 <p>+20mm RCMB054H1 pag. 1202</p>	 <p>+40mm RCMB054H2 pag. 1202</p>	 <p>RCMB015 pag. 1213</p>	 <p>RCMB742 pag. 1231</p>	 <p>RCMBA146 pag. 1249</p>
--	--	--	--	---

Miscelatore e comando venduti separatamente
Mixer and handle sold separately / Mischer und Griff separat verkauf / Mitigeur et manette vendus séparément / Mezclador y mando vendidos separatamente